

SUPERVISORY SKILLS

INTRODUCTION



WORLD HEALTH ORGANIZATION



Programme for
Control of Diarrhoeal Diseases

WS 18
87Su-3
c.2

Revised 1987

RR.

45833

WS18

87 Su-3

C.2

INTRODUCTION

INTRODUCTION

Illness and death of children under 5 years of age is a serious problem in the developing world today. In some developing countries, childhood deaths can be as much as 60% of all deaths. Recent estimates show that each year 75 to 350 of every 1,000 children born alive will die before they reach the age of 5. Of these deaths, 40 to 200 will occur during the first year of life. These childhood deaths are caused by a combination of factors, including childhood disease, undernutrition, and economic underdevelopment.

The World Health Organization (WHO) recognizes the need for community-based activities in primary health care to deal with the major causes of childhood illness, death and disability. There are effective ways to prevent or treat some of the major childhood disease problems, such as diarrhoea, diseases preventable by immunization, malaria, and acute respiratory infection. WHO's Expanded Programme on Immunization (EPI), Programme for Control of Diarrhoeal Diseases (CDD), Programme of Acute Respiratory Infections (ARI), and other activities seek to assist countries to reduce childhood illness, death and disability. Many of these activities are directed primarily toward children under 5 years of age.

PURPOSE OF THE COURSE

Controlling childhood illness, death and disability will require long-term efforts on the part of a community. If health workers are to contribute to these efforts, they must receive adequate supervision and support.

This course is designed to teach the following supervisory skills.

- * PLANNING - making plans for health activities
- * MONITORING - regularly checking to see if activities are being carried out as planned
- * TRAINING - helping people to do tasks
- * EVALUATING - determining the extent to which plans are achieved

The course is for supervisors of local health areas. A local health area may have a health facility and community health workers that provide health services to the local population.

Health services are activities designed to prevent or treat particular health problems or concerns. Examples of health services are diarrhoea treatment, malaria treatment, childhood immunization, education on child care and feeding, and family planning. The supervisory skills taught in this course can be used to supervise any health services in an area. The course is not limited to supervision of diarrhoea treatment or prevention services.

HOW THIS COURSE DIFFERS FROM OTHER COURSES

This course differs from other training courses you may have taken in that the material will not be presented to you by lecture. Instead, you will be given a set of instructional booklets, called **MODULES**, that have the basic information and include exercises for you to work. You can work through these modules at your own speed. This method of training will allow you to actually practice important skills to be learned, and to see right away what you are learning. As a result, you will learn the skills more quickly, and remember them better.

Each module in the course is designed to help you learn skills necessary to do one particular duty, such as training health workers. In most cases, the examples and exercises in the modules describe how to apply the skills being taught to supervision of diarrhoea treatment. Some examples and exercises show how the skills can be used to supervise other health services, such as measles immunization, prenatal care, and malaria treatment.

You are encouraged to discuss any problems or questions with the facilitator, and to show him completed exercises promptly. He will give you comments on your work and any suggestions for improvement.

WHAT A FACILITATOR IS

A facilitator is a person who will help you learn the skills presented in the modules. Your facilitator may be your supervisor or may be the person responsible for training in your district or region. He or she is very familiar with the material being taught, and will answer questions, talk with you about exercises, lead group discussions, and generally provide any help you need to complete the course successfully. Besides the modules themselves, the facilitator will be the most important resource available to you.

COURSE MATERIALS TO BE USED

In addition to this introduction, there are 7 modules in the course. You will work through one module at a time, in the order shown below. The titles of the modules are:

- Community Involvement
- Treatment of Diarrhoea
- Prevention of Diarrhoea
- Targets
- Planning and Monitoring Activities
- Training
- Evaluating Progress and Course Summary

Participants at some courses may also work through the ARI modules Management of the Child with Cough and Management of the Child with an Ear, Nose, or Throat Infection, or selected EPI modules. Your facilitator will tell you if you will complete any of these other modules.

WAYS TO COMPLETE THE COURSE

The course can be completed in different ways as described below. Your facilitator will explain exactly which way you will do the course.

- * A group of participants can meet together and complete the course in one 6- or 7-day period.
- * Participants, either singly or in groups, may have several meetings with the facilitator over a longer period of time, working through one or 2 modules at each meeting.

The time limits for completion of the course are flexible.

HOW YOU SHOULD PROCEED

You will complete each module by reading it and working through the practice exercises. There is a section at the end of each module called "Definitions of Terms." Refer to that section whenever you read an unfamiliar term.

There may be several types of exercises in a module. These are described on the next page.

- * Short-answer exercise: In a short-answer exercise, you will be asked to write an answer to the exercise. The correct answer will be given in the module (usually on the following page) so you can check your own work.
- * Individual work followed by discussion with a facilitator: In this type of exercise, you will first be asked to write an answer to the exercise. You will then talk with a facilitator, who will review your answers with you and help resolve any questions you may have. The facilitator will also give you a copy of the answer sheet for the exercise.

Before each exercise of this type, you will see a picture like this:

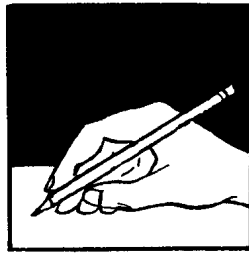

- * Individual work followed by group discussion:

In this type of exercise, you will first be asked to write an answer to the exercise. Then, when all participants are ready, the facilitator will lead a small group discussion to review the answers. The group discussion will also allow you to discuss how the information in the course materials can be used in your health area.

- * Role-play followed by group discussion:

In this type of exercise, you will be asked to play the role of a person in a situation that may arise in your job. For example, you may be asked to play the role of a supervisor of a health facility in a community meeting, or of a community health worker in a training session. After the role-play session, the facilitator will lead a small group discussion about the role-play.

Before each exercise in which there will be a group discussion or role-play, you will see a picture like this:



When doing any exercise, always do the following:

- * Read and follow the instructions carefully.
- * Write your answers to the exercise in the space provided in the module, unless no written response is requested.
- * If you have any questions about the exercise, talk to the facilitator.

Remember, the facilitator is here to help you. Feel free at any time to ask about the materials or about supervision of health services. If a facilitator cannot answer particular technical questions, he or she will find someone who can.

APPLICATION OF SUPERVISORY SKILLS

On page 7 is a flowchart which shows the major duties of a supervisor of health workers, and the order in which those duties would be done. Each box on the flowchart contains one major duty. Fold out the flowchart and look at it now.

Read the flowchart from left to right, following the arrows. When boxes are on top of each other, like B and C,

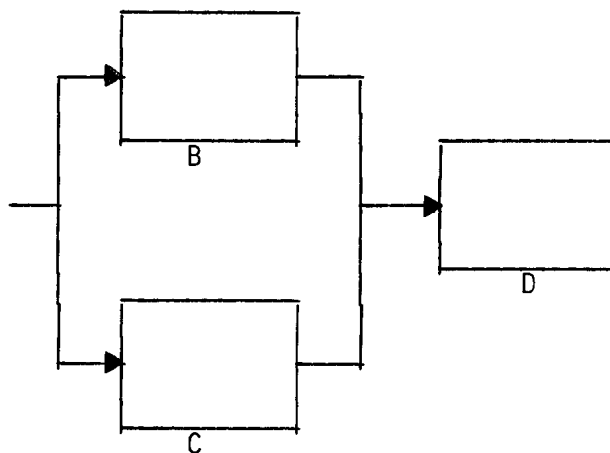

it means that a supervisor can do the work described in those boxes in any order, or at the same time, but he must do the work in both boxes before he does the work described in box D.

When boxes are next to each other, like this,

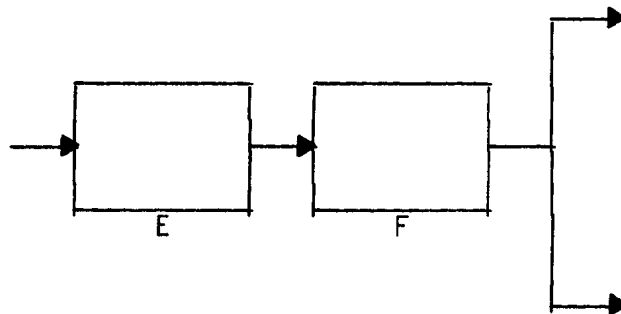

it means that a supervisor should do the work on the left before doing the work on the right.

To do the duties shown on the flowchart, you will need the basic supervisory skills taught in this course, that is, **PLANNING, MONITORING, TRAINING, and EVALUATING.**

Major Duties Of A Supervisor of Health Workers

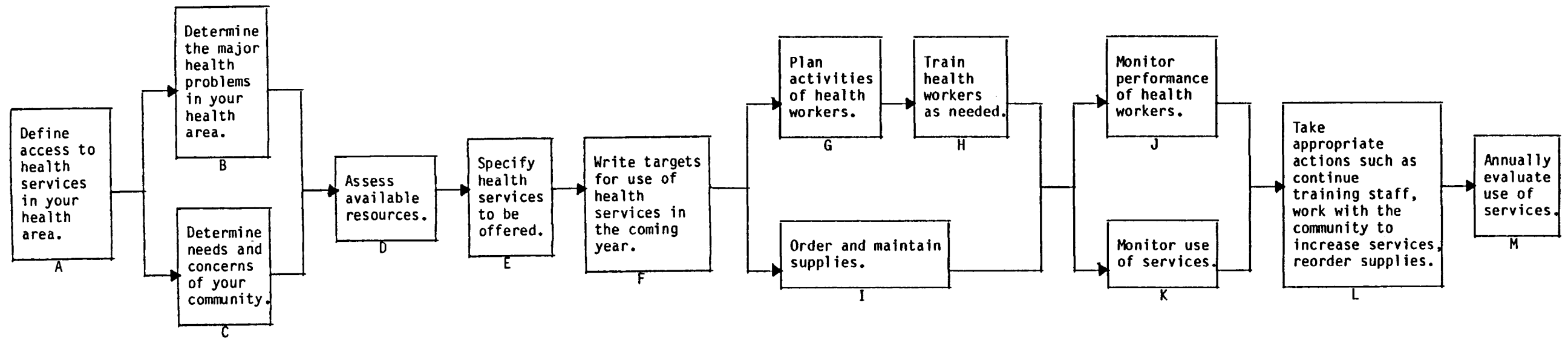

THE SKILLS NEEDED
TO DO THESE
MAJOR DUTIES:

ARE TAUGHT IN THE
FOLLOWING MODULES
OF THIS COURSE:

A	Community Involvement
B	Community Involvement
C	Community Involvement, Prevention of Diarrhoea
D	Community Involvement
E	Community Involvement, Treatment of Diarrhoea
F	Targets
G	Treatment of Diarrhoea, Prevention of Diarrhoea, Planning and Monitoring Activities
H	Treatment of Diarrhoea, Prevention of Diarrhoea, Training
I	Targets
J	Planning and Monitoring Activities
K	Evaluating Progress
L	Community Involvement, Treatment of Diarrhoea, Prevention of Diarrhoea, Targets, Training
M	Evaluating Progress

This module, Introduction, has given some background information on this course. When you have no more questions about it to ask the facilitator, it is time to begin the next module.

SUPERVISORY SKILLS

Prepared by the
WORLD HEALTH ORGANIZATION
PROGRAMME FOR CONTROL OF
DIARRHOEAL DISEASES

through a contract with

ACT International

2295 Parklake Drive
Atlanta, Georgia 30345
USA