

Kindly address any comments within 2 months of the date of mailing to Dr A. Mechkovski, Drug Management and Policies, Quality Assurance, World Health Organization, 1211 Geneva 27, Switzerland.

## DISSOLUTION TEST FOR SOLID ORAL DOSAGE FORMS

This test determines the amount of active ingredient(s) released from a solid oral dosage form, such as from tablets or capsules, using a known volume of dissolution medium within a predetermined length of time. This test method may not be applicable to certain oral dosage forms.

### Apparatus

All parts of the apparatus, including any metal, that may come into contact with the sample to be tested or the dissolution medium should be made from a chemically inert material and should not adsorb, react or interfere with the preparation or the dissolution medium.

The dissolution assembly should be constructed in such a way that any vibration is reduced to a minimum.

An apparatus must be used which preferably allows for all operations to be visible.

The apparatus "Paddle" (see Figure 1) consists of the following parts:

- a cylindrical vessel of suitable glass or other transparent material with a hemispherical bottom and a nominal capacity of 1000 ml; a cover that prevents evaporation of the medium, bearing a central hole to accommodate the shaft of the stirrer and other holes for the thermometer and the devices permitting the withdrawal of liquid;
- a stirrer consisting of a vertical shaft having at its lower end a blade (see Figure). The blade is constructed around the shaft in such manner that it is flush with the bottom of the shaft; the shaft's axis is within 2 mm of the axis of the vessel and the bottom of the blade is  $25 \pm 2$  mm from the inner bottom of the vessel; the upper part of the shaft is connected to a motor provided with a speed regulator; a smooth rotation of the stirrer should be maintained without any significant wobble;
- a water-bath that maintains the dissolution medium at  $37 \pm 0.5$  °C.

For the apparatus "Basket" use the apparatus "Paddle" described above, except that in the stirring element the paddle is replaced by the basket (see Figure 2).

The basket consists of two components. The top part, with a vent, is attached to the shaft. It is fitted with three spring clips, or other suitable means, that allow removal of the lower part for introduction of the preparation being examined and that firmly hold the lower part of the basket concentric with the axis of the vessel during rotation. The lower detachable part of the basket is made of welded-seam cloth, with a wire thickness of 0.254 mm diameter and with 0.381 mm square openings, formed into a cylinder with a narrow rim of sheet metal around the top and the bottom. For use with acidic media the basket may be plated with a 2.5- $\mu$ m layer of gold. The distance between the inside bottom of the vessel and the basket is maintained at 23 to 27 mm during the test.

This document is not issued to the general public, and all rights are reserved by the World Health Organization (WHO). The document may not be reviewed, abstracted, quoted, reproduced or translated, in part or in whole, without the prior written permission of WHO. No part of this document may be stored in a retrieval system or transmitted in any form or by any means - electronic, mechanical or other - without the prior written permission of WHO.

The views expressed in documents by named authors are solely the responsibility of those authors.

Ce document n'est pas destiné à être distribué au grand public et tous les droits y afférents sont réservés par l'Organisation mondiale de la Santé (OMS). Il ne peut être commenté, résumé, cité, reproduit ou traduit, partiellement ou en totalité, sans une autorisation préalable écrite de l'OMS. Aucune partie ne doit être chargée dans un système de recherche documentaire ou diffusée sous quelque forme ou par quelque moyen que ce soit - électronique, mécanique, ou autre - sans une autorisation préalable écrite de l'OMS.

Les opinions exprimées dans les documents par des auteurs cités nommément n'engagent que lesdits auteurs.

### Test conditions

The following specifications are given in the individual monograph:

- the composition and volume of the dissolution medium;
- the rotation speed of the paddle or basket;
- the time, the method and the amount for sampling of the test solution or the conditions for continuous monitoring;
- the method of analysis; and
- the limits of the quantity or quantities of active ingredients required to dissolve within a prescribed time.

### Dissolution medium

If a buffer is added to the dissolution medium, adjust its pH to within  $\pm 0.05$  units of the prescribed value. Prior to testing, remove any dissolved gases that could cause the formation of bubbles.

### RECOMMENDED PROCEDURE

Place the volume of dissolution medium as stipulated in the individual monograph, in the vessel; assemble the apparatus and place it in the water-bath; allow the temperature of the dissolution medium to reach  $37 \pm 0.5$  °C and remove the thermometer.

When apparatus "Paddle" is used, allow either 1 tablet or 1 capsule of the sample to sink to the bottom of the vessel before starting the rotation of the blade, taking care that no air bubbles are present on the surface of the dosage form. In order to stop the dosage form from floating and to anchor it to the bottom of the vessel, use a suitable device such as a wire or glass helix.

When apparatus "Basket" is used place either 1 tablet or 1 capsule in a dry basket at the beginning of each test. Lower the basket into position before rotation.

Immediately start rotation of the blade or basket at the rate specified in the individual monograph.

Withdraw a specimen from a zone between the surface of the dissolution medium and the top of the rotating blade or basket, not less than 10 mm below the surface\* and at least 10 mm from the vessel wall, at the time or time intervals specified (see Annex 1, section 3.3).

Either replace the volume of dissolution medium with an equal volume of liquid removed, except where the continuous flow technique is used or where a single portion of liquid is removed, or compensate the loss of liquid by calculation.

For the filtration of the removed liquid, use an inert filter of suitable pore size. Use a filter which does not cause significant absorption of the active ingredient from the solution nor contain substances extractable by the dissolution medium, and does not interfere with the specified method of analysis. Use centrifugation as an alternative.

Unless otherwise indicated, proceed in parallel with five additional tablets or capsules.

Determine the quantity of active ingredient dissolved in the specified time limit as indicated in the individual monograph. The result should be expressed as a percentage of the content stated on the label.

Details of the procedure are given in Annex 1 to serve as a guidance for persons not familiar with the method.

Annex 2 is offered as an example for the purpose of monitoring the performance of the system. It does not constitute a part of the requirements.

---

\* Recommended, 4.5 cm

FIGURE 1: Paddle Apparatus\*

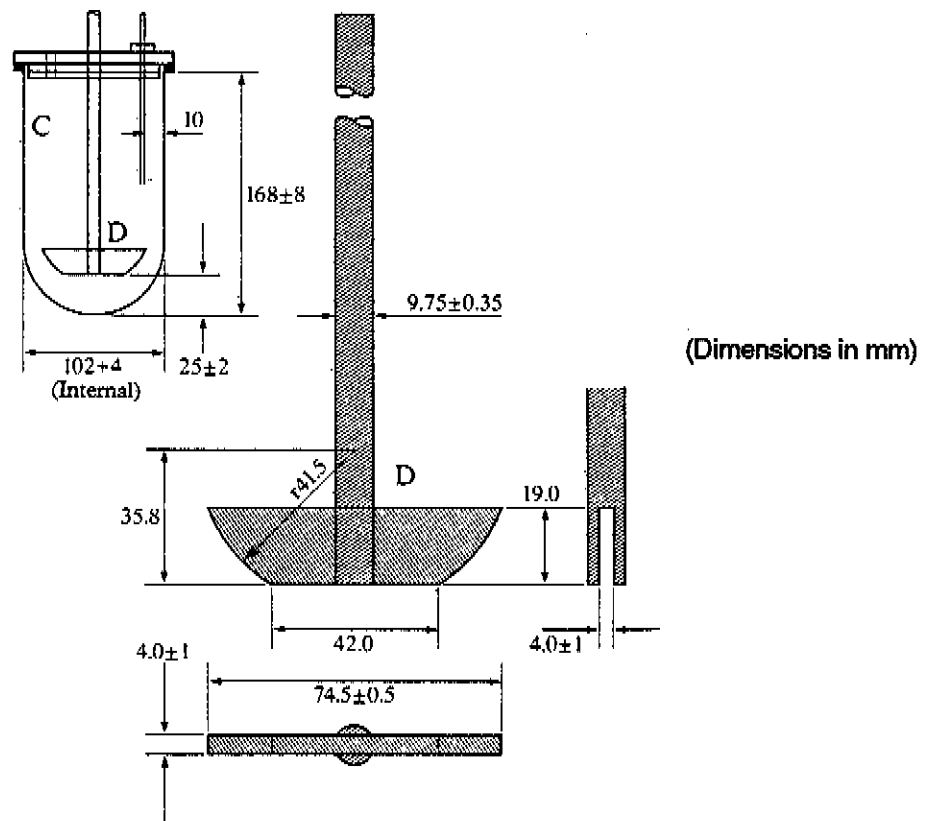
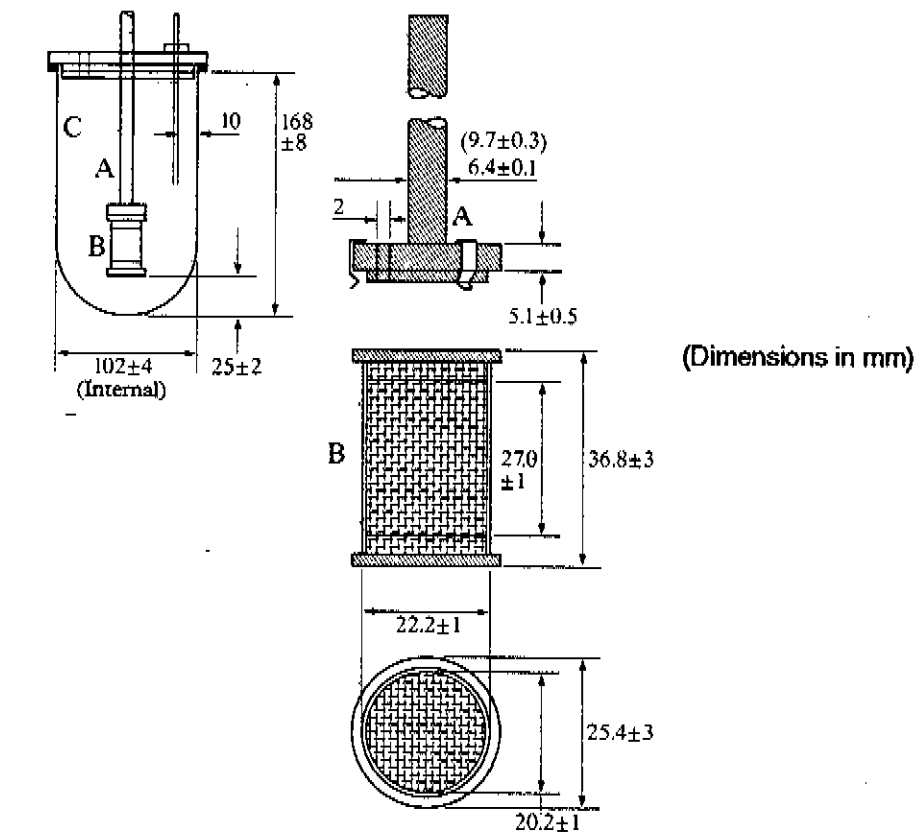

FIGURE 2: Basket Apparatus\*



\* Permission has been requested from The British Pharmacopoeia Commission for the authorization of reproduction of these drawings.

## DETAILS OF THE PROCEDURE

### 1. Verification of equipment (6 sets)

- Check the straightness of the shaft visually and with a ruler.
- Examine the paddle or basket for cracks in coating, if applicable.
- Check the paddle or basket for specified dimensions, particularly any deviation in the evenness of the blade and in distance from the axis.
- Mount the paddle or basket and check its central position.
- Check the apparatus to ensure the desired speed can be maintained at  $\pm 2\%$  through the length of the test.
- Check the level of vibrations of the whole apparatus, preferably measured with a vibration meter, and eliminate any sources of vibration to keep the readings of displacement below 1.3 mm.
- Inspect the paddle or basket for cleanliness and any portion of the apparatus which will be in contact with the test solutions and particularly for crevasses or streaks in the paddle/shaft joint.
- Insert the paddle or basket into the unit, adjust it to the specified distance from the bottom of the vessel ( $25 \pm 2$  mm) in order for it to be in an operational position.
- Insert the shaft into the drive and adjust each vessel with a centering gauge. Mark the vessels to permit their easy replacement without losing the correct centered position.
- Inspect the vessels for any abnormalities in dimension or shape, especially of the hemispherical bottom and internal radius.
- Calibrate the system using suitable calibrators\*.

### 2. Preparation of the dissolution medium

- Select the dissolution medium (see section 6).
- Check the pH of the dissolution medium to two decimal places, using a suitably calibrated pH-meter.
- Dissolved gases can cause bubbles to form which may change the results of the test. In such cases, dissolved gases should be removed prior to testing using a suitable method (e.g. filtration under vacuum or in an ultrasonic water-bath).
- Preheat the medium to 37 °C or slightly above, measuring the temperature with precalibrated precision thermometers.

### 3. Getting ready for the test

#### 3.1 Apparatus

- Adjust the speed and ensure that the speed can be maintained at  $\pm 2\%$ .
- Check the tilt of all shafts and adjust their positions to within 1.5 °.

---

\* For example, calibrator tablets as available from *The United States Pharmacopeia*.

- Recheck the centering of the vessels with a gauge and correct if the tilt adjustments were altered.
- Set vertical frame limits, using markers or collars, in order to insert the dosage form to be tested without causing changes between each test.
- Prepare the drug dosage forms ready for dropping into the vessels.

### 3.2 Water-bath

- Transfer the dissolution medium into the vessel, accurately measured to  $\pm 1\%$ ; check the temperature; check the volumetric procedure used for the subsequent determination as well as any weighing equipment employed.
- Use a transparent water-bath which allows for visual monitoring of the process of disintegration/disaggregation, or the observation of possible presence of air.
- Adjust the bath temperature as to maintain a temperature of  $37 \pm 0.5$  °C in the vessels.
- Ensure that the fluid in the bath is above the top level of the medium in the vessels.
- Ensure that the position of the water-bath is level.

### 3.3 Sampling procedures

- Documentation
  - Determine the intervals of sampling as given in the sampling procedure, and decide if a staggered or a simultaneous start of the six tests is convenient.
  - Determine whether the time interval allowed between sampling is sufficient (especially for manual sampling).
  - Record all information concerning:
    - the reference substance used and how it is prepared;
    - if any interference is known from excipients, and to apply a preevaluated correcting factor in the calculations;
    - if the pH of the solution to be tested is the same as that of the test medium used;
    - if the diluent for the assay is not the dissolution medium; and
    - if there are any effects known from other solvents.
- Inspection
  - In manual sampling, check if the syringe or other sampling device is clean and equipped with appropriate filters.
  - Observe that no interference occurs with the sampling probes.
  - Ensure that the specimen is withdrawn from a zone midway between the surface of the dissolution medium and the top of the rotating blade, not less than 10 mm from the vessel wall, and that each subsequent sample is taken in the same way.

### 3.4 Selection and checking of analytical procedures

- Use the method specified in the corresponding monograph.
- The correct filters should be used to avoid adsorption or interference, unless separation is performed by centrifugation.
- Suitable tubing should be used in automated equipment to avoid adsorption.
- If a spectrophotometric method is used, it is preferable to operate in the linear range of absorption (extinction) values at the specified wavelength.

#### 4. Carrying out the test

- Insert the dosage form into the vessels.
- Examine the system to ensure that no air bubbles are present.
- Start the rotation of the paddle or basket, and simultaneously start the stopwatch for sequential sampling.
- For simultaneous sampling drop the dosage form as rapidly as possible into each vessel ("paddle" method).
- For sequential sampling in the method with the "paddle" apparatus, wait for the paddles to rotate, start the stopwatch when dropping the dosage form as close as possible to the centre of the first vessel, and repeat the procedure.
- Check at frequent intervals the temperature of the water-bath and that of the dissolution medium and note on the check list.
- Complete the check list.
- Proceed with the sampling.

#### 5. Summing up

- Check the temperature of the medium in the vessels and record any deviations from the tolerance of  $\pm 0.5^{\circ}\text{C}$
- Record the speed of rotation.
- Ensure that all data are recorded or printed before discarding the samples (possible problems may only be solved by duplication).
- Note any unusual appearance, such as a silvery hue which indicates the release of dissolved gas.
- Note the condition of any undissolved part of the dosage form, such as its position, form etc. (this information may be valuable for the investigation into the reasons of problems).
- Check the volume of the contents of one or two vessels to ascertain if evaporation took place which could affect the analytical results.

**6. Example of suitable buffers**

• Buffer pH = 1.3

Dissolve 2 g of sodium chloride R in 800 ml of deionized water, adjust the pH to 1.3 with hydrochloric acid (~70 g/l) TS, and dilute to 1000 ml with water.

• Buffer pH = 2.5

Dissolve 2 g of sodium chloride in 800 ml of deionized water, adjust the pH to 2.5 with hydrochloric acid (~70 g/l) TS, and dilute to 1000 ml with water.

• Buffer pH = 3.5

Dissolve 7.507 g of glycine R and 5.844 g of sodium chloride R in 800 ml of deionized water, adjust the pH to 3.5 with hydrochloric acid (~70 g/l) TS, and dilute to 1000 ml with water.

• Buffer pH = 4.5

Dissolve 6.8 g of potassium dihydrogen phosphate R in 900 ml of deionized water, adjust the pH to 4.5 either with hydrochloric acid (~70 g/l) TS or sodium hydroxide (~80 g/l) TS, and dilute to 1000 ml with water.

• Buffer pH = 6.9

Dissolve 3.4 g of potassium dihydrogen phosphate R and 3.55 g of disodium hydrogen phosphate R in 800 ml of deionized water, adjust the pH to 6.9 with sodium hydroxide (~80 g/l) TS, and dilute to 1000 ml with water.

• Buffer pH = 7.2

Dissolve 9.075 g of potassium dihydrogen phosphate in deionized water to produce 1000 ml = solution A. Dissolve 11.87 g of disodium hydrogen phosphate R in sufficient water to produce 1000 ml = solution B. Mix 300 ml of solution A with 700 ml of solution B.

**PROPOSED (non-mandatory)  
CHECK LIST OF PERFORMANCE**  
(one sheet per test)

**Name of product**  
International Nonproprietary Name.....  
Proprietary Name.....

**Date**.....

	<b>Verified</b>	<b>Further details (values and comments)</b>
<b>1. Spectrophotometer</b>		
• Cleanliness of cells	<input type="checkbox"/>	.....
<b>2. Dissolution apparatus</b>		
• Aspect of apparatus	<input type="checkbox"/>	.....
• Aspect of device(s)	<input type="checkbox"/>	.....
– single/multi-spindle (3/6 vessels)	<input type="checkbox"/>	.....
• Cleanliness of paddle or basket	<input type="checkbox"/>	
• Cleanliness of vessel(s)	<input type="checkbox"/>	
• Dissolution medium – buffer (name and composition).....		
– pH of buffer	<input type="checkbox"/>	.....
– deaerated water	<input type="checkbox"/>	.....
• Filling of vessel and its position	<input type="checkbox"/>	.....
• Level of the dissolution medium	<input type="checkbox"/>	
• Position of paddle or basket (2.5 cm from the bottom of the vessel)	<input type="checkbox"/>	
• Insertion of tablets: – time interval	<input type="checkbox"/>	.....
– position	<input type="checkbox"/>	.....
• Initial speed	<input type="checkbox"/>	
– after 15 minutes	<input type="checkbox"/>	
– after 30 minutes	<input type="checkbox"/>	
• Initial temperature of dissolution medium	<input type="checkbox"/>	
– after 15 minutes	<input type="checkbox"/>	
– after 30 minutes	<input type="checkbox"/>	
<b>3. Sampling</b>		
• Cleanliness of withdrawal device (e.g. needle)	<input type="checkbox"/>	
• Initial position of device (e.g. 4.5 cm from the surface of the dissolution medium)	<input type="checkbox"/>	.....
• Position of device throughout the test	<input type="checkbox"/>	.....

### RESULTS

Name of product

Date

% dissolved/ time (t)	t1	t2	t3	t4	t5	t6
spindle no. or test no. 1						
2						
3						
4						
5						
6						
M						
$\sigma$						
RSD %						

\*\*\*