

APPENDIX B

**DRINKING WATER QUALITY CONTROL
IN URBAN AREAS**

**CASE STUDY: SEDACUSCO WATER COMPANY
CITY OF CUZCO, PERU**

CONTENTS

	Page
1. Background.....	151
2. Introduction.....	151
3. Rationale	152
4. Goals and Objectives.....	153
4.1 Main Goal.....	153
4.2 Specific Objectives.....	153
5. Strategy.....	153
6. Indicators	154
6.1 Water Quality	154
6.2 Service Quality	154
6.3 State of Repair of the Components of the Supply System.....	155
7. Methods and Procedures.....	155
7.1 Prior Considerations	155
7.2 Planning and Execution	158
7.3 Quality Assurance of Data	159
Annexes	
Annex 1 Responsibilities.....	161
Annex 2 Sampling Parameters and Frequencies	165
1. Introduction	167
2. Physical, Chemical and Bacteriological Requirements, and Sampling Frequency	167
3. Chlorine Residual.....	167
Annex 3 Components of the Water Supply System.....	169
Annex 4 Collection and Preservation of Samples.....	175
1. Introduction	177
2. Containers and Volumes	178
3. Selection of Sampling Sites in the Network.....	178
4. Sample Collection	181
5. Preservation	183
6. Identification.....	184
7. Packing and Transportation.....	185
8. Sampling Methods.....	185
8.1 Sampling from Faucets.....	185
8.2 Sampling in Open Wells or Storage Reservoirs.....	186
Annex 5 Training Program.....	189
Annex 6 Supply Areas	193

Annex 7	Number of Samples	197
1.	Scope	199
2.	Number and Frequency of Samples	199
3.	Cost.....	201
Annex 8	Data Collection Forms	203
Annex 9	Quality Assurance of Data	207
1.	Introduction	209
2.	Number of Evaluations Conducted (1)	209
3.	Consistency of the Results (2)	209
4.	Number of Direct Supervisions (3)	210
5.	Number of Verifications Conducted in the Field (4).....	210
6.	Quality of Field Work (5)	210

List of Tables

Annex 2

Table 1	Analytical Determinations and Number of Samples per Year	167
Table 2	Determination of Chlorine Residual.....	167

Annex 3

Table 1	Treatment Plants	171
Table 2	Surface Sources.....	171
Table 3	Ground Sources. Wells	171
Table 4	Ground Sources. Filtration Galleries	171
Table 5	Ground Sources. Springs.....	171
Table 6	Components. Storage Reservoirs	171
Table 7	Components. Distribution Reservoirs	172
Table 8	Components. Pump Stations	173
Table 9	Components. Cisterns	173
Table 10	Components. Pressure Relief Boxes.....	173

Annex 4

Table 1	Containers and Type of Preservatives by Group of Determinations	183
Table 2	Form for Water Sample Collection and Assessment of Service Quality Distribution Network.....	184

Annex 6

Table 1	Characteristics of the Supply Areas	195
---------	---	-----

Annex 7

Table 1	Number of Analytical Determinations per Year, SEDACUSCO	200
Table 2	Number of Chlorine Residual Determinations per Year, SEDACUSCO.....	200
Table 3	Cost of Analytical Determinations	201

Annex 8

Table 1	Distribution Network.....	205
Table 2	Components.....	206
Table 3	Treatment Plant.....	206

Annex 9

Form E-1 Quality Assurance of Data..... 212

List of Figures

Figure 1 Sampling Sites in Open Distribution 179
Figure 2 Sampling Sites in Closed Distribution System..... 180
Figure 3 Sampling Sites in Mixed Distribution Systems 180

1. Background

Before the 1991 cholera outbreak in Peru, most countries in Latin America and the Caribbean concentrated on the quantity rather than the quality of water. Today, the authorities are more concerned with improving the quality of drinking water, and they are paying greater attention to surveillance and control. Many countries have been motivated to execute programs for the surveillance and quality control of drinking water as part of their environmental health measures to prevent the transmission of gastrointestinal diseases.

Drinking water quality has a strong impact on people's health because water is a vehicle of transmission for many microorganisms of gastrointestinal origin, pathogenous to human beings. Among the more representative pathogenous agents which may be present in drinking water, we have bacteria, viruses, and to a lesser extent, protozoa and helminths. These microorganisms differ widely in size, structure, and constitution, which explains why their survival in the environment, as well as their resistance to treatment processes, also differ significantly.

Another factor of great importance is the conservation of the quality of water in the distribution system. This factor is linked with: a) state of conservation of the physical infrastructure of the distribution network; b) management of the system; and c) handling of water in the home. At this point we should also mention quantity, continuity, coverage, and cost: taken as a whole, these indicators make it possible to determine the quality of the water supply system and identify its service level.

2. Introduction

Water for human consumption has been defined in the World Health Organization (WHO) *Guidelines for Drinking Water Quality* as that water which is “suitable for human consumption and for all normal domestic purposes, including personal hygiene.” Implicit in this definition is the principle that the use of this water should not present any kind of health risk such as chemical irritation, intoxication, or microbiological infection harmful to human health.

The microbiological quality of drinking water is of a great primary importance, and the monitoring of bacterial indicators such as total coliforms and thermotolerant coliforms should be given the highest priority. Chemical pollution is also very important, but it is not associated with acute effects on human health, and has a lower short-term priority than bacteriological contamination, often becoming irrelevant in areas where water-related microbiological and parasitic diseases are strongly prevalent.

Water that is fit for human consumption when it enters the distribution system can deteriorate before reaching the consumer. Once in the distribution system, water can become contaminated for different reasons: crossed connections; backsiphonage; broken pipes; bad condition of home connections, fire hydrants, defective tanks and reservoirs;

and during the laying of new pipes or repair work carried out without safety measures. Another recontamination factor, significant in developing countries where there is a shortage of water, is the interruption of the supply as a result of rotation of service from one supply area to another.

In low-reliability systems, the constant interruption of the water supply system leads to the deterioration of the physical, chemical, and especially the microbiological quality of water in the consumers' homes, because of inadequate handling and storage.

The concepts and procedures set forth in this document are based on the *Guidelines for Drinking Water Quality* developed by the Pan American Center for Sanitary Engineering and Environmental Sciences (OPS/CEPIS), with the financial support of the U.S. Environmental Protection Agency (EPA) (see Part I of this document). With a view to validating the methodology in an urban environment, CEPIS came to an agreement with the water supply agency of Cuzco (SEDACUSCO) for the implementation of a pilot project on drinking water quality control in the city of Cuzco.

The methodology for urban areas has been designed to determine the sanitary condition of the water supply services by evaluating the quality of the drinking water and the sanitary condition of the components of the water supply system, which together will make it possible to define the service level provided by SEDACUSCO.

3. Rationale

Water supply systems should be designed, operated and maintained in such a way as to preserve and conserve drinking water quality. However, it is not unusual to find fortuitous situations caused by poor conditions of the infrastructure, which affect the quality of drinking water. Defects and shortcomings in the infrastructure may be the result of bad design, bad construction (or careless construction supervision), or poor maintenance. They may also be caused by natural or human factors, such as earthquakes or social disruptions, which render the structures of the water supply system unable to protect and maintain the drinking water quality.

The community's attitude toward the water supply system is more passive in an urban environment than in rural areas. This is because their water supply service is managed by a water supply agency, supervised by the regulatory agency, and monitored by the Ministry of Health, as well as being subject to supervision by civil organizations.

Moreover, the water supply agencies are staffed with professionals duly trained in the areas of management, operations, and maintenance, all of whom do their best to deliver a good water supply service in exchange for the payment of an established tariff. The consumers are normally able to afford this tariff, which is used to pay staff and to purchase the supplies required to operate and maintain the water supply system efficiently.

The quality or level of the supply service is another factor of great importance for the improvement of the beneficiary population's health. Ideally, the whole community should be

served efficiently and effectively. However, it is often the case that the water supply service has limited coverage and/or very low continuity. This means that sectors of the population have to store their water to cover their basic needs, which results in the deterioration of the water quality and the consequent exposure of consumers to communicable water-related diseases.

4. Goals and Objectives

4.1 Main Goal

To establish the bases for implementation by SEDACUSCO of a drinking water quality control program, which will determine the quality of water for human consumption in the city of Cuzco.

4.2 Specific Objectives

- a) Determine the quality of the drinking water;
- b) define the degree of deficiencies in the components of the water supply systems;
- c) identify corrective measures;
- d) plan investments.

5. Strategy

The objectives will be reached as follows:

- The quality of drinking water in the distribution system will be determined by physical, chemical, and bacteriological evaluation of the water, from the catchment to the beginning of the home connection. To this effect, three groups of evaluation sites will be established: a) outlets from treatment plants, which may be represented by the feeder mains or storage reservoir; b) components such as distribution reservoirs and tanks; and c) the distribution network.
- The condition and degree of conservation of the water supply infrastructure will be evaluated by direct inspection of the main system components, to identify any defects that may affect the conservation of the drinking water quality.
- Identification and prioritization of remedial measures will be accomplished with the assistance of computer software which will process data on water quality in each of the supply areas, and data on the sanitary condition of the main components of the water supply system.

The following is the information required for planning the control activities: a) inventory of the components of the water supply system, b) identification of water supply areas, c) acceptable parameters and limits, d) findings of water sample analyses, and e) sanitary inspection.

The quality control department will be responsible for planning. To this effect, it must have access to information concerning the physical, operational, and maintenance parts of the water supply system. With this information, it will proceed to locate the components and supply areas, taking into account the influence of supply sources and components, especially storage reservoirs, wells, pressure-relief chambers, etc., linking them to the population of users. Fixed and random sampling sites will be established, taking existing recommendations into consideration. The sampling program will be developed on the basis of sampling frequency and obligatory parameters for each type of structure.

Planning, sampling, on-site testing, and sanitary inspections are the responsibility of the quality control department; while physical, chemical, and bacteriological analyses will be conducted by the SEDACUSCO central laboratory. Data processing and the drafting of annual and other periodic reports, as well as follow-up of the implementation of corrective measures, will also be the responsibility of the quality control department.

6. Indicators

Corresponding to the objectives indicated above, the result indicators which will be obtained from the water quality control program are: a) water quality; b) continuity and pressure (service level); and c) state of conservation of the components of the water supply system.

6.1 Water Quality

Water distributed through the supply systems should be innocuous. This implies that the water quality must comply with the physical, chemical, and bacteriological standards set down by the health authorities, to ensure that the water will not be harmful to consumers' health.

In the specific case of SEDACUSCO, the analytical parameters have been established by the regulatory agency, SUNASS (National Superintendence of Water and Sanitation), based on the analytical capacity of the SEDACUSCO laboratory. These parameters have been grouped according to the main parts of the water supply system, such as a) outlet from surface sources; b) outlet from underground sources; c) outlet from reservoirs; and d) distribution network.

6.2 Service Quality

Water supply systems must comply with the minimum requirements for which they were conceived and built. These minimum requirements are synthesized in satisfying the basic water supply needs of the community, within the concept of quality and its link to the preservation and conservation of the consumers' health.

For this project, we have considered that the service level can be assessed by determining the functional characteristics of the water supply system, such as a) continuity of the water supply; and b) water pressure.

6.3 State of Repair of the Components of the Supply System

Conservation of the quality of drinking water is dependent on the absence of physical defects in the components which make up the water supply system; as well as the availability of protective elements for the conservation of the water's physical, chemical, and bacteriological characteristics.

Observation of the condition and state of repair of the infrastructure is accomplished by sanitary inspection. The objective of the inspection is to identify possible defects in the components of the water supply system, and in the operational and maintenance practices which may imply risks for the conservation of the drinking water quality.

The information provided or obtained in the course of the sanitary inspection work will make it possible to identify the measures required to correct any defects which may have been detected (associated with construction, operation, maintenance, or any other deviation from accepted standards of normal practice), in order to minimize the risk of contamination of water intended for human consumption.

7. Methods and Procedures

7.1 Prior Considerations

Prior to the initiation of a water quality control program by SEDACUSCO, a clear definition was needed of the responsibilities of the quality control unit and of the relationship of this unit to the other offices of the water supply company. It has been decided, in principle, that the quality control unit should report directly to General Management and receive the support of the water-testing laboratory at the Santa Ana plant.

This independence will imply the need to appoint the required staff and to provide furniture, office equipment, and appropriate means of transportation. In addition, and from an entrepreneurial standpoint, the quality control unit should be given the support of the operations area for sampling and chlorine residual testing in reservoirs, re-pumping stations, and treatment plants.

The laboratory, based on the number of samples to be tested, will need to determine its requirements with regard to equipment and chemical supplies, prepare testing procedure manuals, and implement the analytical quality control program.

The quality control office, for its part, should schedule control activities and train sampling staff. It will also be important to set up a quality assurance program to monitor the information gathered during the sampling process and sanitary inspections.

- a) *Responsibilities:* It is understood that the quality control of drinking water is a corparative task, shared by all offices of SEDACUSCO, with the quality control office at

their head. However, internal guidelines will need to be issued to specify the functions and responsibilities of each of the participants in the planned control program (see Annex 1).

- b) *Basic equipment:* The Quality Control Office will have the minimum facilities necessary to execute the water quality control program in the city of Cuzco. Minimum facilities include physical space and equipment (desks, computers, etc.).
- c) *Laboratories:* The Santa Ana laboratory has the necessary consumables and supplies for performing water quality control, such as physical space, furniture, equipment, instruments, glassware, chemicals for physico-chemical testing, culture media for bacteriological tests, among others.
- d) *Water quality criteria:* The regulatory agency has established, for the city of Cuzco, the parameters to be analyzed and the sampling frequency, including the determination of chlorine residual at different sites: treatment plants, components, and distribution network (see Annex 2). In the case of the samples to be taken from the distribution network, it has been decided that the network will be divided into sectors based on supply areas, and that this sectorization will be in accordance with a) the hydraulic areas of the distribution network; b) the supply source; c) the influence of the system components; d) water pressure, and e) the fact that each supply area should cover no more than 20,000 inhabitants.

Sporadic determination of chlorine residual and thermotolerant coliforms has also been considered for household installations, to assess the degree of conservation of quality inside the home. Another decision agreed on is that the chlorine residual and pH testing should be performed during sampling, while the other analyses will be conducted at the SEDACUSCO laboratory.

- e) *Basic information:* The information required for the planning of quality control activities consists mainly of: the definition of the characteristics of each of the components of the water supply system, the configuration of the water supply system, and the geographical limits of the hydraulic sectors of the city of Cuzco. Annex 3 lists the characteristics of each of the components of the supply system, and a diagram of the location and limits of the eleven hydraulic sectors.
- f) *Manuals for sample collection and on-site analyses:* The sampling must be carried out by trained staff to ensure that the water samples are representative of the supply system and that they will not be contaminated during the sampling and transportation processes. To that end, staff must be trained to comply strictly with the procedures of sampling, preservation, packing and transportation of samples to the laboratory. They must also be trained to determine on site the free chlorine content, pH and certain other types of information relative to the supply system. The staff in charge of this work must therefore be exclusive and enjoy the absolute trust of the quality control office.

The sampling sites will be:

- Outlets from groundwater sources such as springs and water wells;
- outlets from water treatment plants;
- outlets from components (storage or distribution tanks pressure-relief chambers, etc.);
- pumphines and feeder mains;
- distribution network. The sampling points must be evenly spread throughout the distribution system and be proportional to the number of users, taking into account:
 - sites of social responsibility such as: health centers, schools, places of mass food preparation, public standpipes.
 - dead points, low pressure points or restricted supply points.

Annex 4 describes the method for the collection and preservation of samples and the special care to be taken in sample collection.

- g) *Laboratory analyses:* With regard to the analyses to be carried out by the Santa Ana Plant laboratory, it is recommended that they follow universally accepted procedures, in order to guarantee the results of the analyses and render them comparable. The *Standard Methods for the Examination of Water and Wastewater* of the American Public Health Association (APHA), the American Water Works Association (AWWA) and the Water Environment Federation (WEF) (1995) has therefore been adopted.
- h) *Training:* The training program must involve all tiers of the organization connected with the control program, paying special attention to the formation of the staff responsible for field activities and data processing.

The quality of the information produced by the quality control unit depends on the work carried out by the staff responsible for collecting samples, conducting sanitary inspections, performing analyses, processing information, etc. For this reason the staff must be trained to do their work to a high standard. A good training program will ensure that the data and their processing will be standardized and comparable among the different generators of information, thereby facilitating systemization at the regional and national level. The training should be designed to prepare personnel in:

- Planning the task;
- identifying the characteristics of the water supply services;
- evaluation of components and identification of sanitary risks;
- collection and preservation of samples;
- field analyses;
- microbiological, physical and chemical analyses;
- processing of information;
- interpreting and reporting results.

Collecting information on the physical characteristics of the water supply systems, handling the forms, taking samples and performing field analyses require specific training, which must be both theoretical and practical.

Annex 5 contains a model training program for staff in charge of field activities.

7.2 *Planning and Execution*

The activities involved in the quality control work for urban water supply services are:

- a) *Planning*: —Before beginning its control work, the quality control office must obtain general information about the characteristics of the water supply system, from supply sources to the secondary distribution network, considering all components, as well as total population and number of users, public establishments— especially those relating to education and health, and high-density areas, service level, etc. These data will help it identify all the factors that might affect the water quality, and will facilitate the planning of control activities.

In addition, planning should include the definition of:

- Sampling frequency and number of analytical determinations required.
- Frequency of sanitary inspections.
- Sampling and analysis procedures.
- Accessibility.
- Establishments that form part of the information flow.
- Preparation of the database.

Annex 6 lists the supply areas into which the city of Cuzco has been divided. The division was made based on hydraulic sectors, and taking into consideration the characteristics of the supply system; for example, supply source, components which provide direct or indirect services, total population and user population, among others. Annex 7 shows the number of samples to be collected throughout the city during the present year.

- b) *Execution*: After planning the different activities involved, the quality control unit can proceed with the control program. The following tasks have been defined: a) gathering information; b) sampling and testing; c) analyzing information; d) identifying corrective measures; and e) reporting. See Annex 8 for models of the forms used for gathering data relevant to the treatment plants, reservoirs, distribution network, and sanitary inspections.
- c) *Analysis of the information*: The analysis of the information will permit the rating of three basic aspects: a) drinking water quality; b) service level; and c) condition of the infrastructure.

With reference to water quality, it will be classified in groups according to its origin, thus considering: a) outlet from water treatment plant or from underground sources, only with

regard to the quality of drinking water supplied to the population, but excluding the quality of raw water; b) outlet from intake structures such as storage reservoirs, distribution reservoirs, and tanks; and c) distribution networks, both primary and secondary. Only in very special cases will water samples be collected in consumers' homes, since SEDACUSCO's responsibility does not exceed property limits.

- d) *Corrective measures:* After processing the information from the field and the laboratory, it will be possible to identify the main problems in the water supply system that has been evaluated.

7.3 *Quality Assurance of Data*

The data obtained by the staff responsible for the water quality control work should be subject to validation to ensure accuracy. The performance of the persons responsible for field work is evaluated on the following five points:

- Number of evaluations conducted
- Consistency of the results
- Number of direct supervisions
- Number of verifications in the field
- Quality of field work

See Annex 9 for the procedure to be carried out in assuring the quality of the data.

ANNEX 1

RESPONSIBILITIES

Different agents are involved in the process of controlling the quality of drinking water. Among these, we can mention operational and laboratory staff, and the staff of the control offices.

The responsibilities of each one of them are listed below:

Control office: In this office, several levels have been defined: a) planners; b) data-entry clerks; c) inspector-samplers; d) supervisors; and e) drivers.

Planners are responsible for defining the scope of the monitoring program, outlining the strategies to comply with the regulatory agency's requirements, and planning field work, that is, fixing dates and sites for sample collection. In addition, and with the help of SEDACUSCO programmers, they will shape the program based on what has been planned, and assess the reliability of the data obtained by the samplers and inspectors. They should periodically process the data and report to the pertinent levels on the results of their work.

Data-entry clerks are responsible for entering into the data-base all the data from sample collection, sanitary inspections, and the findings of chlorine residual analyses conducted in treatment plants, reservoirs, and the distribution networks.

Inspector-samplers are responsible for conducting sanitary inspections of the different components of the water supply system; collecting water samples from treatment plants, reservoirs, and the distribution network; filling out sample forms; conducting field tests, preserving samples, packing them properly so that they will not become contaminated during transportation, and taking them to the laboratory; and, finally, reporting the results of their work to the pertinent levels.

Supervisors are responsible for verifying that the data provided by inspector-samplers are accurate. To this effect, they will validate through random sampling part of the information supplied by the staff responsible for inspection of the sampling.

Drivers are responsible for the transportation of the staff engaged in water quality control.

Laboratory: Responsible for conducting the analytical determinations specified in the sample delivery form, applying analytical quality control procedures to guarantee the quality of the data. In addition, in the event of suspicious results, the laboratory should report these immediately to the quality control office, so that the latter may proceed to collect new water samples, and, if necessary, adopt measures to prevent the spreading of any micro-organism or toxic substance that may affect the health of the consumers.

Operational control: The responsibility of this office is to provide support in the determination of chlorine residual at the outlets from treatment plants and reservoirs. In addition, it implements the necessary remedial measures if there are reports of problems in the quality of the city's water supply.

ANNEX 2

SAMPLING PARAMETERS AND FREQUENCIES

1. Introduction

For the Drinking Water Quality Control Program to be implemented in the city of Cuzco, the regulatory agency has selected a set of parameters to evaluate the quality of the drinking water.

2. Physical, Chemical, and Bacteriological Requirements, and Sampling Frequency

Table 1 shows the determinations to be performed by the Quality Control Program.

Table 1. Analytical Determinations and Number of Samples per Year

Determinations	Outlet from sources		Reservoirs	Distribution network
	Ground	Surface		
Total coliforms	4	52	12	12
Thermotolerant coliforms	4	52	12	12
Turbidity	4	365	12	52
PH	4	365	12	26
Conductivity	4	365	12	26
Total hardness	1	4	4	2
Chlorides	1	4	4	2
Sulfates	1	4	4	2
Nitrate	1	4	4	2
Color	1	4	4	2
Iron	1	4	4	2
Manganese	1	4	4	2
Aluminum	0	12	0	2

3. Chlorine Residual

Testing for the presence of chlorine residual is not an indispensable requirement for the assessment of drinking water quality. However, its determination is considered a decisive element in the conservation of the bacteriological quality of the water. To this effect, the determination of chlorine residual should be carried out in different parts of the supply system as indicated in Table 2.

Table 2. Determination of Chlorine Residual

Parts of the system	Location	Frequency
Components	Outlet from plants	Every 6 hours
	Reservoirs larger than 4.000 m ³	Every 6 hours
	Reservoirs smaller than 4.000 m ³	Once daily
Distribution network	Supply area	Once daily

ANNEX 3

COMPONENTS OF THE WATER SUPPLY SYSTEM

INVENTORY AND CHARACTERISTICS OF THE WATER SUPPLY SYSTEM OF THE CITY OF CUZCO

Input Information. Water Supply System

Table 1. Treatment Plants

Name	Control Code	SEDACUSCO Code	Location	Source of supply	Treatment capacity (m ³ /d)
Santa Ana	PTA-001	INPLT0001	Av. Humberto Vidal Unda 421	Piuray lagoon and springs*	26,956.8
Jaquira	PTA-002	INPLT0002	APV Los Jardines	Jaquira springs and surface waters **	777.6

* Springs: Fortaleza Nueva, Chaullamarca, Cuncunyac, Ñahuimpugio.

** Springs: Fortaleza Nueva, Chaullamarca, Cuncunyac, Ñahuimpugio.

Table 2. Surface Sources

Name	Control Code	SEDACUSCO Code	Location	Catchment capacity (m ³ /d)
Piuray lagoon	FS-001			

Table 3. Ground Sources. Wells

Name	Control Code	SEDACUSCO Code	Location	Working condition	Volume (m ³ /d)	Depth (m)	Pumping power (hp)
Well 1	PZ-001	FS01	Piñipampa	Good	9,158.4	65	160
Well 2	PZ-002	FS02	Piñipampa	Good	9,158.4	65	160
Well 3	PZ-003	FS03	Piñipampa	Good	9,158.4	65	160
Well 4	PZ-004	FS04	Piñipampa	Good	9,158.4	65	160

Table 4. Ground Sources. Filtration Galleries

Name	Control Code	SEDACUSCO Code	Location	Working condition	Production flow (m ³ /d)
Salkantay	GA-001	GA01	Salkantay	Good	2,008.8

Table 5. Ground Sources. Springs

Name	Control Code	SEDACUSCO Code	Location	Working condition	Production flow (m ³ /d)
Kor Kor*	MN-002	REDIS0002	Kor Kor	Good	7,715.52
Jaquira	MN-003	INRLT0003	Jaquira	Good	10,005.12

* Chaullamarca and Fortaleza Nueva.

Table 6. Components. Storage Reservoirs

Name	Control Code	SEDACUSCO Code	Location	Working condition	Storage capacity (m ³)
Santa Ana R-3	R-003	INRES0003	Av. Humberto Vidal Unda 421	Good	6,500
Picol Larapa R-12	R-012	INRES0012	Larapa Grande	Good	4,500
Jaquira	R-039	INRES0039	Jaquira	Good	300
El Arco	R-032	INRES0032		Good	400
Tambillo	R-017	INRES0017	Tambillo	Good	1,000

Table 7. Components. Distribution Reservoirs

Name	Control Code	SEDACUSCO Code	Location	Type	Working condition	Storage capacity (m ³)
Los Andenes R-1	R-001	INRES0001	Jn. Antisuyo 420, Los Andenes	Circular – Reinforced concrete	Good	1,800
Puquin R-2	R-002	INRES0002	Puquín	Circular – Reinforced concrete	Good	455
Picchu R-4	R-004	INRES0004	Av. Túpac Amaru 422, cuadra 01	Rectangular – Reinforced concrete	Good	3,400
Qoripata R-5	R-005	INRES0005	Fortunato Herrera s/n, Santiago	Square – Reinforced concrete	Good	2,100
Mcal. Gamarra IE R-7	R-007	INRES0007	Mcal. Gamarra	Rectangular – Reinforced concrete	Good	120
Mcal. Gamarra IIE R-8	R-008	INRES0008	Cruzpata	Circular – Reinforced concrete	Good	250
Campiña Baja R-10	R-010	INRES0010	Campiña Baja	Circular – Metal	Good	3,000
Wimpillay R-13	R-013	INRES0013	Wimpillay s/n, Santiago	Circular – Metal	Good	1,500
Ununchis R-42	R-042	INRES0042	Urb. Santa Rosa s/n, San Sebastián	Circular – Reinforced concrete	Good	500
Independencia R-35	R-035	INRES0035	APV Independencia	Circular – Reinforced concrete	Good	150
Villa María R-33	R-033	INRES0033	Villa María	Circular – Reinforced concrete	Good	150
Small reservoirs						
Mosocllacta R-19	R-019	INRES0019	Av. Circunvalación	Rectangular – Reinforced concrete	Good	25
Alto Balconcillo R-20	R-020	INRES0020	APV Balconcillo	Circular	Good	35
Bajo Balconcillo R-21	R-021	INRES0021	APV Balconcillo	Circular	Good	36
Sétima Cuadra R-22	R-022	INRES0022	APV Lucrepata	Rectangular – Reinforced concrete	Good	50
Ucchullo Alto R-23	R-023	INRES0023	APV Cristo Pobre	Rectangular – Reinforced concrete	Good	70
Los Licenciados R-25	R-025	INRES0025	San Sebastián Licenciados	Circular	Good	75
Buena Vista R-29	R-029	INRES0029	Buena Vista	Circular – Reinforced concrete	Good	85
Atocsaycuchi	R-046					
Huarapunku	R-047					
Larapa	R-048					

Table 8. Components. Pump Stations

Name	Control Code	SEDACUSCO Code	Location	Working condition	Pump flow (m ³ /d)	Pumping power (hp)
Rumicolca	EB-002	EB2	Rumicolca	Good		
Qollana	EB-003	EB3	Qollana	Good		

Table 9. Components. Cisterns

Name	Control Code	SEDACUSCO Code	Location	Working condition	Storage capacity (m ³)
Rumicolca	CT-002		Rumicolca	Good	
Qollana	CT-003		Qollana	Good	

Table 10. Components. Pressure Relief Boxes

Name	Control Code	SEDACUSCO Code	Location	Working condition	Diameter (mm)
Zárate	RP-001	RP001	Zárate	Good	4"
Tetecaca	RP-002	RP002	Tetecaca	Good	4" cast iron
Amargura	RP-003	RP003	Amargura	Good	8" cast iron
Puntop C	RP-004	RP004	Ttio, fifth stop	Good	12" cast iron
Pucllanchis	RP-005	RP005	Pucllanchis	Good	3" cast iron
Santa Ana	RP-006	RP006	Santa Ana	Good	14" cast iron
Karigrande	RP-007	RP007	Karigrande	Good	12" cast iron
Bolivar	RP-008	RP008	San Sebastián, third stop	Good	

ANNEX 4

COLLECTION AND PRESERVATION OF SAMPLES

1. Introduction

One of the main components of the Drinking Water Quality Control Program is the evaluation and characterization of the water supplied to the people. Evaluation and characterization of the water are carried out by analyzing the water samples obtained from the supply system.

This Section is concerned with different aspects of the sampling process, and the special care that must be taken from the time the sample is collected up to its arrival at the laboratory.

Care must be taken during the collection and transportation of samples to ensure that the water sample does not become contaminated at these stages. The following requirements must also be met:

Sampling Sites

Select the sampling sites so that the samples obtained will be representative of the water flowing through the supply system.

Taking the Sample

Take an adequate volume of the sample in flasks appropriate for the laboratory.

Preservation

Protect the water sample from any significant change in its composition before its analysis.

Identification

Clearly record the details of the sampling on the cards accompanying the flasks with the water samples.

Packing and transportation

Pack the water samples properly to avoid breakage of the containers or contamination of the contents, and send them to the laboratory as soon as possible for analysis.

The Drinking Water Quality Control Program includes field testing for free residual chlorine, and eventually, determination of turbidity and pH.

2. Containers and Volumes

When taking water samples for analysis, care must be taken in a number of aspects, according to the type of sample.

a) *Bacteriological*

The bottle, jar or flask for taking bacteriological samples must be sterilizable, preferably of glass, with a wide mouth, a securely closing cap or stopper and capacity of no less than 120 milliliters.

b) *Physical*

The sample containers used in this group of analyses can be plastic (polyethylene or polypropylene) or glass, of half-liter capacity, carefully washed with detergent and rinsed with abundant water.

c) *Chemical*

The sample containers used in this analysis group can be plastic (polyethylene or polypropylene) or glass, of one-liter capacity. The washing procedure is similar to the previous one, except that the cleaning with hydrochloric acid must be even more thorough.

3. Selection of Sampling Sites in the Network

The objective of the sampling is to determine the “quality of the water in the supply system,” whether it be in the components or the user’s faucet or at some other outlet of water destined for human consumption.

The sampling points selected in the distribution network must therefore be such as to ensure that the samples are representative of the existing water supply; points inside homes that have private storage should be discarded. The general criteria to keep in mind in selecting the sampling points are that they must:

- a) Be representative of the supply system as a whole and its principal components.
- b) Represent *the quality of the different sources of water supply*. The sampling points should be located immediately outside the outlet from the treatment plant or water well.
- c) Represent the conditions of the least favorable places in the system from the point of view of possible contamination.
- d) Be spread evenly throughout the length and breadth of the water supply system.
- e) Consider the presence of the different components (storage tanks and/or pumping chambers).
- f) Take into account the number of inhabitants served by the supply system.

In addition, the sampling points are selected according to the type of distribution system, which could be open, closed or mixed.

- a) In open distribution systems, the most representative sampling points are those shown in Figure 1.
- b) Likewise, in closed distribution systems the sampling points to be emphasized are those shown in Figure 2.
- c) Finally, in mixed distribution systems the sampling points are selected as shown in Figure 3.

In addition, the following aspects must be considered:

1. Critical points of the system such as areas with old networks, areas with a history of continual breakage, areas with low pressure, or areas exposed to frequent flooding.
2. Areas with a high population density.
3. Supply points for tank trucks and individual collection.
4. Food industry areas.
5. Emergency areas.
6. Areas used for recreation or mass meetings.

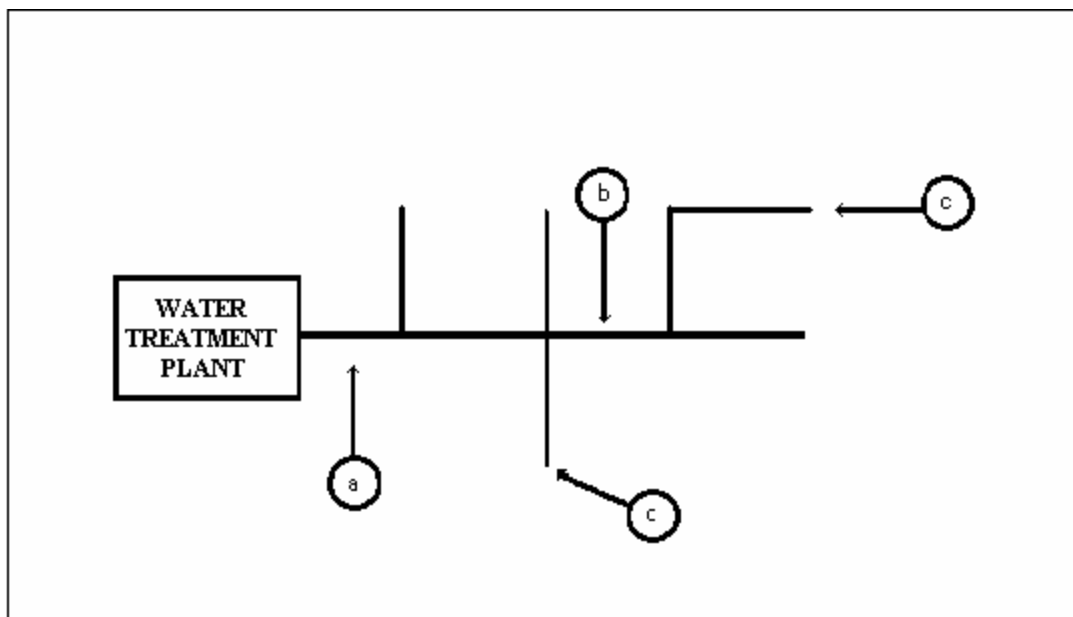

Figure 1. Sampling Sites in Open Distribution

- (a) At the outlet of the water treatment plant. Indicates the quality of the water entering the distribution system.
- (b) At an intermediate point, to be representative of the water in the mains.
- (c) At one or more points that are representative of the water at the ends of the distribution network.

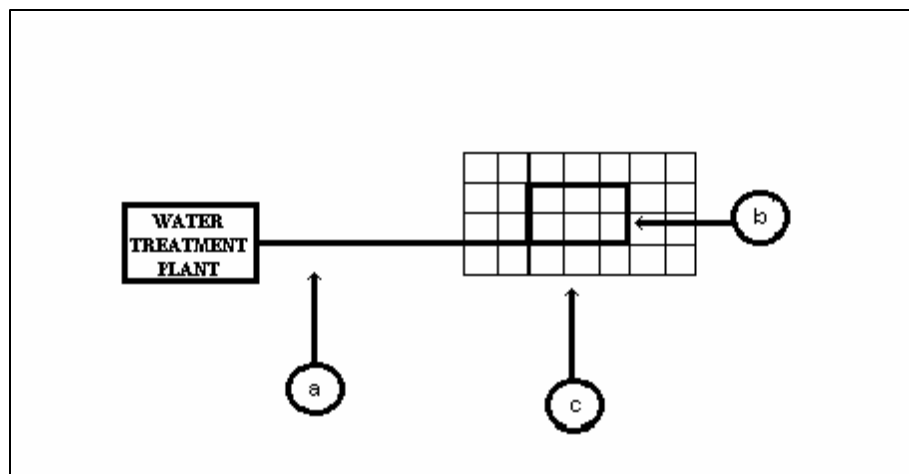

Figure 2. Sampling Sites in Closed Distribution Systems

- (a) At the outlet of the water treatment plant. Indicates the quality of the water entering the distribution system.
- (b) At a point representative of the water in the main circuit.
- (c) At points that are representative of the water in the secondary circuits or at the end of the water distribution network.

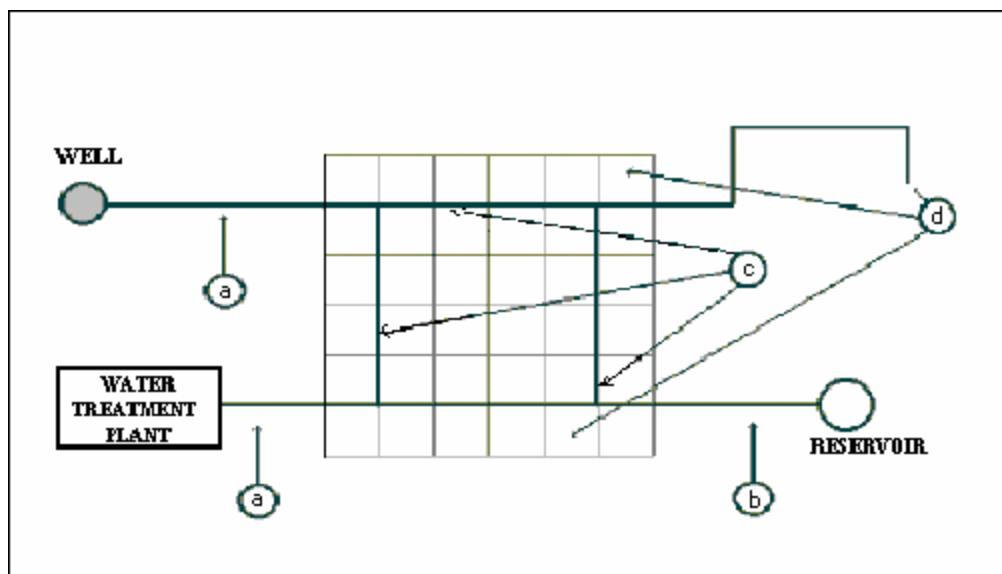

Figure 3. Sampling Sites in Mixed Distribution Systems

- (a) At the outlet of the treatment plant and/or water wells. Indicates the quality of water entering the distribution system.
- (b) At the outlet of the storage components.
- (c) At points representative of the water in the main circuit.
- (d) At points representative of the water in the secondary circuits or at the end of the water distribution system.

4. Sample Collection

General

The collecting or taking of a sample depends on the types of structures or sampling points. These can be classified as follows:

- Components
- Reservoirs
- Feeder mains or pumpmains
- Cisterns
- Distribution network

Samples are collected in the distribution network from home connections linked directly to the distribution network, public standpipes, or pressure relief valves, or any other element within the distribution network itself.

Procedures

Precautions are taken in keeping with the type of analysis. The procedures can therefore be described as follows:

Bacteriological

a.1 Components (reservoirs and cisterns)

Cleaning

Remove any type of residual found around the lid of the component with a brush.

Removal of the Lid

Remove the lid carefully, taking care that no type of residual falls into the component.

Opening of the Sterilized Flask

Untie the string that holds the protecting paper sleeve in place, remove the sleeve and unscrew the top.

Sterilization

Using a flame lit on a wad of absorbent cotton soaked in alcohol, sterilize the external part of the sample flask.

Taking of the Sample

After the flask has cooled, very carefully submerge it in the mass of water, to a depth of approximately 20 centimeters.

Replacing the Stopper

Before replacing the stopper, pour off a small amount of water to leave an air space which will facilitate sample shaking (mixing) at the analysis stage.

Then replace the stopper on the flask and cover with the protecting kraft paper sleeve. Tie this in place with the string.

a.2 Distribution Network (home connections, public standpipes, pressure-reducing valves)

Cleaning the Faucet

Remove from the faucet any material adhering to it that could cause splashing. Carefully clean the mouth of the faucet with a clean cloth to remove any dirt or grease.

Washing out the Faucet

Open the faucet to its maximum flow and let the water run for 1-2 minutes.

Sterilization

Before taking the water sample, close the faucet and sterilize it for one minute with the flame from a piece of absorbent cotton soaked in alcohol. As an alternative, a gas flame or a lighter can be used.

Draining the Faucet before Sampling

Open the faucet carefully and allow the water to flow slowly for 1-2 minutes more, at a speed suitable for filling the sample flask easily.

Opening the Sterilized Flask

Untie the string that is holding the protecting paper sleeve in place, and remove the paper sleeve.

Taking the Sample

Remove the stopper or unscrew the cap and, while holding it in one hand, immediately put the flask under the flow of water and fill it. Leave a small air space to facilitate shaking at the analysis stage.

Sealing the Flask

Replace the stopper on the flask or screw on the cap. Tie the protecting paper sleeve in place with the string.

Chemical

In these specific cases, the same care must be taken during the sampling as that indicated for the bacteriological analyses.

The only exception is in the rinsing of the sample bottles during the sampling process, which should be carried out two consecutive times before taking the final sample. Once the sample has been collected, and depending on the type of analysis to be performed, the appropriate preservative is added.

5. Preservation

It is impossible to recommend the exact time between sample collection and analysis. However, the following general points should be taken into account.

Bacteriological

In the case of samples of drinking water suspected of being slightly contaminated and without any type of preservation (refrigeration) it is acceptable for up to two hours to elapse between the sampling and the beginning of the analysis. Refrigerated samples should be analyzed no later than 24 hours after being taken.

Chemical

This group of analyses should be divided into two parts. The first group includes chlorides, total hardness, sulfates, nitrate, pH, conductivity, and turbidity, which require only refrigeration and a period of up to seven days between sampling and testing.

The second group is represented by aluminum, iron, and manganese. For the preservation of these samples, it is necessary to add 5 milliliters of concentrated nitric acid per liter of sample. The time between collection and testing can be up to three months. Table 1 presents the types of preservatives to be used in the conservation of water samples.

Table 1. Containers and Type of Preservatives by Group of Determinations

Determination	Type of Container and Volume (*)	Preservative
Bacteriological Total coliforms Thermotolerant coliforms	G 120 mL	Refrigeration at 4 °C
Physical Color Turbidity PH Conductivity	P, G 500 mL	Refrigeration at 4 °C
Chemical non-metallic Total hardness Nitrate Chlorides Sulfates	P, G 500 mL	Refrigeration at 4 °C
Chemical metallic Aluminum Iron Manganese	P, G 1000 mL	Nitric acid 5 mL

(*) G = Glass

P = Plastic

6. Identification

Once the water sample has been collected, the sample identification tag should be properly filled in with all the required data.

Table 2 shows models of the forms to be applied in this quality control program.

Table 2. Form for Water Sample Collection and Assessment of Service Quality Distribution Network

Sample number		Supply area	
Date		District	
Address		Time	
Sampling Site		Continuity	
Fixed		Hours per day	
Random		Days per week	
Sampling Point		Determinations	
Home		Coliforms	
School		Turbidity	
Public office		pH/Conductivity	
Shop or store		Physico-chemical	
Food industry		Aluminum	
Miscellaneous industries		Chlorine residual	
Public network		Type of Sample	
Pressure		First	
Pressure		Confirmation	
Sampler			
Components			
Sample number		Code	
Date		Time	
		Determinations	
Sampling Point		Coliforms	
Storage reservoir		Turb./pH/Conduc.	
Distribution reservoir		Physico-chemical	
Small reservoir		Aluminum	
Pump station		Chlorine residual	
Cistern		Type of Sample	
Pressure-relief		First	
Well		Confirmation	
Gallery		SAMPLER	
Spring			
Source/treatment plant			
Sample number		Code	
Date		Time	
		Determinations	
Sampling Point		Coliforms	
Storage reservoir		Turb./pH/Conduc	
Feeder pipe		Physico-chemical	
Source		Aluminum	
Surface		Chlorine residual	
Ground		Type of sample	
Sampler		First	
		Confirmation	

7. Packing and Transportation

The samples sent to the regional laboratory or central laboratory should be adequately packed in strong cases.

The bottles or flasks should be accommodated in the packing cases in such a way as to make it unlikely that they will knock against each other and break. In the event that they need to be refrigerated, this aspect must be taken into account, since extra space will need to be provided for the coolant mixes or the ice.

8. Sampling Methods

8.1. Sampling from Faucets

- a) Remove any foreign matter from the faucet, such as pieces of hose or other objects. Make sure that there are no leaks in the faucet seals or washers. If leaks are detected, they must be repaired before sampling for a bacteriological test. Otherwise, select another sampling point.

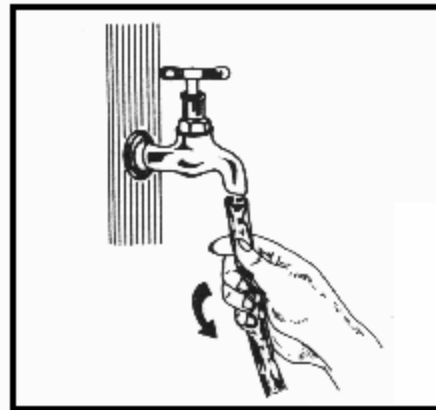

- b) Open the faucet and let the water flow for one to two minutes, before collecting the sample. This procedure cleanses the opening and flushes out water which has collected in the pipe.

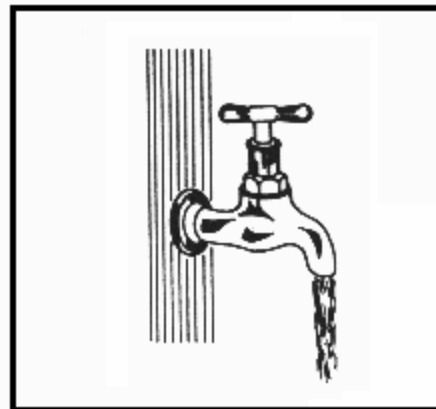

- c) For turbidity and chlorine residual tests, rinse out the sample bottle three times before collecting the actual sample. Proceed with chlorine residual and turbidity analyses. In the case of samples for bacteriological tests, the sample bottle must be sterile and should not be rinsed. If the water is chlorinated, the sample bottle should contain a determined percentage of sodium thiosulfate in order to block the action of chlorine. The bottle should not be filled completely, but should be 1/3 empty to facilitate mixing of the sample. Place the lid on the bottle and cover with the kraft paper sleeve.

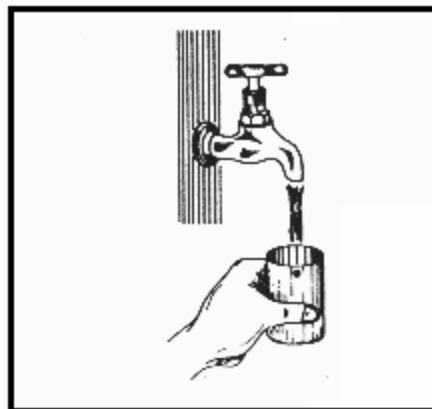

8.2 *Sampling in Open Wells or Storage Reservoirs*

- a) Fasten the hook at the end of the sampling line through the hole in the sampling vessel.

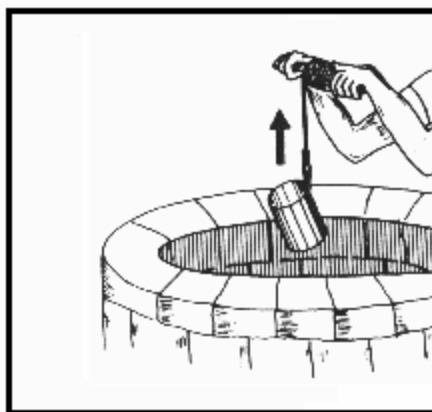

- b) If necessary, tie on an extra length of cord to the line to reach the desired water level. Be very careful not to lose the sampling vessel during this operation.

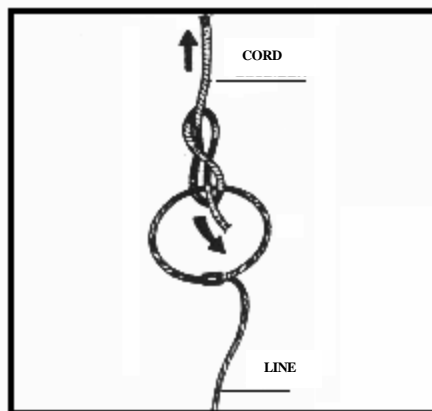

- c) Lower the sterile vessel into the well or reservoir, being careful not to let it touch the walls. Submerge the sample vessel to approximately 30 cm below the surface of the water.

Carefully raise the vessel. Test for chlorine immediately. If free chlorine residual exceeds 0.5 milligrams per liter and there is no turbidity, there is no justification for a thermotolerant (fecal) coliform test. If turbidity is present and/or free chlorine measures less than 0.5 milligrams per liter, take a sample for the thermotolerant coliform test.

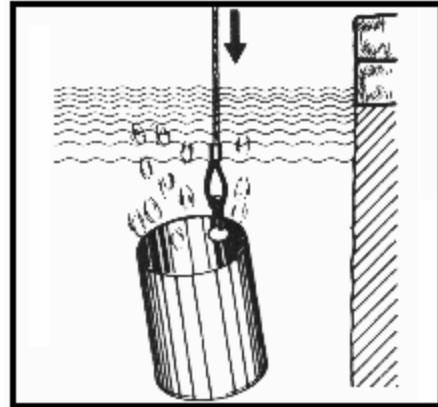

ANNEX 5
TRAINING PROGRAM

**Program for Training Course in Sample
Collection and Sanitary Inspection**

Time	Topic	Type of Session
8:00 - 8:30	Registration	
8:30 – 8:45	Presentation of participants and expectations	Group dynamics
8:45 – 9:15	Water and Health	Presentation
9:15 – 10:00	Ideas on control and surveillance of drinking water quality	Presentation
10:00 – 10:15	Break	
10:15 – 10:45	Drinking water quality standards	Presentation
10:45 – 11:30	Characteristics of water supply services	Presentation
11:30 – 12:30	Sanitary inspection	Presentation
12:30 – 13:30	Lunch	
13:30 – 14:00	Sanitary inspection	Presentation
14:00 – 14:45	Techniques for sample collection and preservation	Presentation
14:45 – 15:30	Field analysis	Practical work
15:30 – 15:45	Break	
15:45 – 16:45	Data management and entry	Presentation
16:45 – 17:30	Roundtable discussion	Roundtable discussion
17:30 – 17:45	Evaluation of the course-workshop	Evaluation
17:45 – 18:00	Closing ceremony	

ANNEX 6

SUPPLY AREAS

ANNEX 7

NUMBER OF SAMPLES

1. Scope

In accordance with the Guidelines for the Surveillance and Control of Drinking Water Quality and the directives of the regulatory agency (Superintendencia Nacional de Saneamiento–SUNASS), the water and sanitation service company for Cuzco, SEDACUSCO, has reformulated its program for the quality control of drinking water.

The city of Cuzco has a population of approximately 245,000 inhabitants, and is served by five different water supply sources (Kor Kor, Jaquira, Salkantay, Piuray, and Vilcanota), and the distribution network has been divided by the operations office into eleven pressure areas. The water supply system has treatment plants, drilled wells, filtration galleries, springs, storage reservoirs, medium and small distribution reservoirs, pump stations, cisterns and pressure relief chambers (see Annex 3 for details).

The supply areas were determined on the basis of the physical characteristics of the distribution network and the number of components. A supply area is defined as *"each of the parts into which the distribution system is subdivided, considering the presence of homogeneous conditions of water quality and pressure and/or operation related to the functioning of the water treatment plant, wells, galleries, springs, reservoirs, pumping chambers, or any other element pertaining to the distribution system, and in which there must reside no more than a determined number of people, according to the supplier's estimation."* In this case, the regulatory agency has established that the number of residents in each supply area should not exceed 20,000.

2. Number and Frequency of Samples

To ensure that the drinking water supply system meets the requirements of the regulatory agency, Table 1 of Annex 2 was taken into account, which establishes the analyses to be performed and the number of samples to be collected yearly, from the outlets of treatment plants, reservoirs, and the distribution network. The zoning of the distribution system, as shown in Annex 7, was also taken into consideration.

In addition, the definition of the number of samples took the following factors into consideration:

- a) Since the groundwater source known as the Kor Kor spring flows into a distribution reservoir, it was categorized as a reservoir and assigned a larger number of samples.
- b) The groundwater source known as the Jaquira spring, because its waters are treated at the plant of the same name, was regarded as a plant outlet even though the sample will be collected at the distribution reservoir fed by the mentioned plant.

- c) The outlet of the Santa Ana treatment plant has been considered as such, even though the sample will be collected at the outlet of the main reservoir which is fed by the mentioned plant.
- d) The remaining reservoirs larger than 120 cubic meters will be treated as such.
- e) Pressure areas were taken as a reference for the identification of the supply areas. To this effect, some of them were subdivided so that the number of inhabitants would not exceed 20,000.

In summary, we have considered two treatment plant outlets, 14 reservoirs, and 21 supply areas.

Table 1 summarizes the number of analytical determinations for each of the main parts of the water supply system.

Table 1. Number of Analytical Determinations per Year – SEDACUSCO

Determinations	Outlets from sources		Reservoirs	Distribution network	TOTAL
	Ground	Surface			
Total coliforms	0	104	168	252	524
Thermotolerant Coliforms	0	104	168	252	524
Turbidity	0	730	168	1,092	1,990
PH	0	730	168	546	1,444
Conductivity	0	730	56	546	1,444
Total hardness	0	8	56	42	106
Chlorides	0	8	56	42	106
Sulfates	0	8	56	42	106
Nitrate	0	8	56	42	106
Color	0	8	56	42	106
Iron	0	8	56	42	106
Manganese	0	8	56	42	106
Aluminum	0	24	0	42	66

In relation to the number of determinations of free chlorine residual, the regulatory agency's directive indicated in Table 2 of Annex 2 was consulted, resulting in the number of samples indicated in the following Table.

Table 2. Number of Chlorine Residual Determinations per Year – SEDACUSCO

Outlets from sources		Reservoirs	Distribution network	TOTAL
Ground	Surface			
0	2,920	6,205	7,665	16,790

3. Cost

Table 3 shows the unit cost demanded for performing each of the analyses, as well as the cost for each of the parts of the water supply system, and the total cost, which amounts to US\$ 13,125.00.

It is estimated that water sample collection and other operational expenses may cost US\$ 20,000, which would bring the total cost for the drinking water quality control program in the city of Cuzco to approximately US\$ 33,000 per year. Divided by the number of people served by the water supply system (245,000), the per capita cost would be US\$ 0.14 yearly, or US\$ 0.08 per family per month.

**Table 3. Cost of Analytical Determinations
(in US\$)**

Determinations	Unit cost US\$	Outlets from sources	Reservoirs	Distribution network	TOTAL
Total coliforms	5.00	520	840	1,260	2,620
Thermotol.coliform	5.00	520	840	1,260	2,620
Turbidity	0.50	365	84	546	995
PH	0.50	365	84	273	722
Conductivity	0.50	365	84	273	722
Total hardness	1.50	12	84	63	159
Chlorides	2.00	16	112	84	212
Sulfates	5.00	40	280	210	530
Nitrate	5.00	40	280	210	530
Color	1.00	8	56	42	106
Iron	5.00	40	280	210	530
Manganese	5.00	40	280	210	530
Aluminum	5.00	120	0	210	330
Chlorine residual	0.15	438	931	1150	2,519
TOTAL		2,889	4,235	6,001	13,125

ANNEX 8

DATA COLLECTION FORMS

ANNEX 9

QUALITY ASSURANCE OF DATA

1. Introduction

The different activities conducted by the water quality control staff should be assessed to ensure the quality of the data collected throughout the evaluation process. Form E-1 is applied for this purpose. It was designed to assess staff performance in five stages:

- Number of evaluations conducted
- Consistency of results
- Number of direct supervisions
- Number of field verifications
- Quality of field work

2. Number of Evaluations Conducted (1)

On Form E-1, opposite the name of the person responsible for the quality control, indicate how many of each type of form have been completed by him/her during the month.

3. Consistency of the Results (2)

The Supervisor should carefully check answers to questions in each of the different types of forms that have been completed and submitted by the control staff in the field.

This revision is to determine whether the person responsible for field work has answered all of the questions in the forms relating to the collection of samples or sanitary inspection and whether, in the supervisor's opinion, the answers are reliable and coherent with reality.

Acceptance or rejection of a form is decided taking into account, in the first place, the number of obligatory answers and, secondly, the reliability of the answers.

If the obligatory questions in each of the forms have not been completely answered, the form is returned so that the person responsible can complete the missing data.

With regard to reliability of the results, the number of inconsistent answers in the form will be counted, and the form will then be accepted or rejected according to the following criteria:

Number of Questions per Form Reviewed	Number of Questions with Doubtful or Mistaken Answers	
	<i>Accept</i>	<i>Reject</i>
6 – 8	0	1
9 – 12	1	2
13 – 20	2	3
21 – 30	3	4
31 – 42	4	5
43 – 65	5	6

If in each batch of forms it is found that the number of evaluations or forms completed is equal to or lower than the “accept” number, the information as a whole is accepted. Otherwise, the whole batch is returned to the person in charge of the field work, for revision.

In line 2 of Form E-1, it should be noted whether the forms were accepted (A) or rejected (R).

4. Number of Direct Supervisions (3)

This section refers to the number of times the supervisor helped or supervised the staff responsible for completing the forms. This activity is known as direct supervision or field training. The number of forms which the supervisor helped to complete or supervised is recorded in the appropriate space, for each type of form.

5. Number of Verifications Conducted in the Field (4)

The supervisor is obliged to verify independently the work of the staff responsible for gathering data in the field. To this effect, he selects ten percent of a given type of form, at random, to compare the data recorded with the real situation and thus evaluate the quality of the work performed by the staff member responsible.

The supervisor will record – for each type of form – the number of forms selected and verified in the field.

6. Quality of Field Work (5)

This value is determined for forms selected and verified in the field by the supervisor (step 4).

The supervisor records in line 5 the percentage of errors made by the person responsible for gathering data in the field, referring only to the number of questions answered.

The information is rejected if the percentage of mistaken answers is higher than ten percent (10%).

Example:

The supervisor evaluated three forms of the M2 type, in which 60 questions were answered in each form, and four, six and five errors were found, respectively. The error is determined as follows:

$$\frac{4 + 6 + 5}{3 \times 60} \times 100 = 8.3\%$$

Number of Forms Questions per Form

QUALITY ASSURANCE OF DATA

Date of report _____ Supervisor _____

Indicate number of evaluations per type of form conducted by each person

Name of person evaluated	Evaluation (1)	Form*					
		IS-1	IS-2	IS-3	IS-4	IS-5	IS-6
	1						
	2						
	3						
	4						
	5						
	1						
	2						
	3						
	4						
	5						
	1						
	2						
	3						
	4						
	5						

- (1)
1. Number of forms completed within the month, per type
 2. Consistency of results (A = Accepted; R = Rejected)
 3. Direct supervision (number of forms supervised)
 4. Verification in the field (number of forms verified)
 5. Quality of work (percentage)

* Sanitary inspection forms and others subject to validation.