

APPENDIX C

**SURVEILLANCE OF THE QUALITY OF RURAL
WATER SUPPLY SERVICES**

CASE STUDY: CUZCO, PERU

CONTENTS

	Page
1. Background	219
2. Introduction	219
3. Rationale	220
4. Goals and Objectives	221
4.1 Main Goal.....	221
4.2 Specific Objectives	221
5. Strategy	221
6. Indicators	222
6.1 Water Quality.....	222
6.2 Quality of the Service.....	223
6.3 State of Repair of the Components of the Supply System.....	223
6.4 Habits of Hygiene	224
6.5 Management of the Supply Services.....	224
6.6 Diarrheal Diseases and Skin Infections	225
6.7 Rating the Service.....	225
7. Methods and Procedures	225
7.1 Prior Considerations	225
7.2 Planning and Execution	228
7.3 Quality Assurance of Data.....	229
8. Bibliography	230
Annex 1 Responsibilities	231
Annex 2 Implementation and Complementation of Laboratories	235
Annex 3 Sampling Parameters and Frequencies	239
1. Introduction.....	241
2. Physical, Chemical, and Bacteriological Requirements.....	241
3. Sampling Frequency	241
4. Residual Chlorine	241
5. Quality of the Water Supply Service	244
Annex 4 Assessment of the Water Supply Service (Miscellaneous Forms and Instructions for Filling Them Out)	245

Annex 5	Sample Collection and Preservation, and Reporting of Findings	267
1.	Introduction.....	269
2.	Containers and Volumes.....	270
3.	Selection of Sampling Sites in the Network.....	272
4.	Sample Collection.....	275
5.	Identification	279
6.	Preservation.....	279
7.	Packing and Transportation	280
8.	Reporting the Findings	280
Annex 6	Training Program	283
Annex 7	Information Flow	287
1.	Introduction.....	289
2.	Reporting the Findings	289
3.	Planning	290
4.	Information Flow	290
5.	Notification and Follow up	292
Annex 8	Places to be Evaluated	297
Annex 9	Determination of Number of Samples	305
1.	Scope.....	307
2.	Work Plan.....	307
3.	Number and Frequency of Samples.....	307
4.	Timeframe for Surveillance of Water Systems (203 Systems Constructed by DIGESA-COSUDE)	308
5.	Budget	308
Annex 10	Sanitary Inspection Report Form	317
Annex 11	Quality Assurance of Data	321
1.	Introduction.....	323
2.	Number of Evaluations Conducted (1).....	323
3.	Consistency of Results (2)	323
4.	Number of Direct Supervisions (3).....	324
5.	Number of Verifications Conducted in the Field (4)	324
6.	Quality of Field Work (5)	324

List of Tables

Annex 2

Table 1	Implementation and Reimplementation of Laboratories	237
---------	---	-----

Annex 3

Table 1	Bacteriological Parameters	241
Table 2	Parameters that Affect Health	242
Table 3	Parameters that Affect Acceptability of the Water.....	242
Table 4	Sampling Frequency (Treatment Plant, Groundwater Sources and Services Reservoirs).....	243
Table 5	Sampling Frequency (Distribution Network).....	243
Table 6	Frequency of Evaluation.....	244

Annex 4

Form M-1	Community Registration Form.....	248
Form M-2	Form to Assess Management and Coverage.....	249
Form M-3	Form to Assess the Sanitary Condition of the Water Supply Infrastructure.....	250
Form M-4	Form for Collecting Water Samples and Assessing the Quality of the Service....	253
Form M-5	Form to Verify Habits of Hygiene and Presence of Diseases in the Communities	254
Form M-6	Form to Verify Habits of Hygiene in the School Population	256

Annex 5

Table 1	Containers and Type of Preservatives by Group of Determinations	279
Form L-1	Report on Analysis of Water Samples	281
Form L-2	Report on Physico-Chemical Analysis of Water Samples.....	282

Annex 7

Form N-1	Letter - Re. Surveillance of the Quality of Drinking Water.....	293
Form N-2	Letter - Re. Surveillance of the Quality of Drinking Water.....	294
Form S-1	Summary of Activities Carried Out During the Quarter	295
Form S-2	Summary of Activities Carried Out During the Quarter	296

Annex 8

Table 1	Water Supply System. SANSABUR Project.....	299
---------	--	-----

Annex 9

Table 1	Analyses Required in Three Years Planned for Control and Surveillance of Drinking Water Quality	308
Table 2	Chronogram of Activities	308
Table 3	Cost of Analyses.....	309

Table 4	Sampling Plan for the Surveillance of the Water Quality, and Water Supply Administration and Systems	311
Table 5	Summary of the Water Supply Systems. SANSABUR Project Ground and Surface Water	312
Table 6	Number of Samples for Physico-Chemical Analysis Groundwater 2001	313
Table 7	Number of Samples for Physico-Chemical Analysis	313
Table 8	Number of Samples for Chlorine Residual Analysis Groundwater – 2001.....	314
Table 9	Number of Samples for Chlorine Residual Analysis Surface Water – 2001.....	315
Table 10	Projections	315

Annex 11

Form E-1	Quality Assurance of Data.....	326
----------	--------------------------------	-----

List of Figures**Annex 5**

Figure 1	Criteria for Decision on Testing for Coliforms	270
Figure 2	Sample Bottle	271
Figure 3	Sampling Sites in Open Distribution Systems	273
Figure 4	Sampling Sites in Closed Distribution Systems	274
Figure 5	Sampling in Mixed Distribution Systems	274

Annex 7

Figure 1	Information Flow Surveillance of the Quality of the Water Supply Services.....	291
----------	--	-----

Annex 9

Figure 1	Program for the Surveillance of Drinking Water Quality, SANSABUR Project..	310
----------	--	-----

1. Background

Before the 1991 cholera outbreak in Peru, most countries in Latin America and the Caribbean concentrated on the quantity rather than the quality of water. Today, the authorities are more concerned with improving the quality of drinking water, and they are paying greater attention to surveillance and control. Many countries have been motivated to execute programs for the surveillance and quality control of drinking water as part of their environmental health measures to prevent the transmission of gastrointestinal diseases.

Drinking water quality has a strong impact on people's health because water is a vehicle of transmission for many microorganisms of gastrointestinal origin, pathogenous to human beings. Among the more representative pathogenous agents which may be present in drinking water, we have bacteria, viruses, and to a lesser extent, protozoa and helminths. These microorganisms differ widely in size, structure, and constitution, which explains why their survival in the environment, as well as their resistance to treatment processes, also differ significantly.

Another factor of great importance, especially in rural areas, is the conservation of the quality of water in the distribution system. This factor is linked with: a) state of conservation of the physical infrastructure of the distribution network; b) management of the system; and c) handling of water in the home. At this point we should also mention quantity, continuity, coverage, and cost: taken as a whole, these indicators make it possible to determine the quality of the water supply system and identify its service quality.

2. Introduction

Water for human consumption has been defined in the World Health Organization (WHO) *Guidelines for Drinking Water Quality* as that water which is “*suitable for human consumption and for all normal domestic purposes, including personal hygiene.*” Implicit in this definition is the principle that this water should not present any kind of health risk such as chemical irritation, intoxication, or microbiological infection harmful to human health.

The microbiological quality of drinking water is of a great primary importance, and the monitoring of bacterial indicators such as total coliforms and thermotolerant coliforms should be given the highest priority. Chemical pollution is also very important, but it is not associated with acute effects on human health, and has a lower short-term priority than bacteriological contamination. Chemical pollution therefore often becomes irrelevant in areas where water-related microbiological and parasitic diseases are strongly prevalent.

Water that is fit for human consumption when it enters the distribution system can deteriorate before reaching the consumer. Once in the distribution system, water can become contaminated for different reasons: crossed connections; backsiphonage; broken pipes; poor condition of home connections, fire hydrants, defective tanks and reservoirs; and during the laying of new pipes or repair work carried out without safety measures. Another recontamination

factor, of great importance in developing countries where there is a shortage of water, is the interruption of the supply as a result of rotation of service from one supply area to another.

In low-reliability systems, the constant interruption of the water supply system leads to the deterioration of the physical, chemical, and especially the microbiological quality of water at the home level, because of inadequate handling and storage.

The concepts and procedures set forth in this document are based on the *Guidelines for the Surveillance and Control of Drinking Water* developed by the Pan American Center for Sanitary Engineering and Environmental Sciences (PAHO/CEPIS), with the financial support of the U.S. Environmental Protection Agency (EPA). With a view to validating the methodology in a rural environment, CEPIS came to an agreement with the Saneamiento Básico de la Sierra Sur project (SANBASUR) to set up a pilot project in the Cuzco Health Region, where SANBASUR is sponsoring the construction of water supply and sanitation systems in cooperation with the Ministry of Health, specifically the Ministry's Dirección Ejecutiva de Salud Ambiental del Cuzco (DESA-CUZCO) [Executive Office of Environmental Health for Cuzco].

The methodology to be applied is designed to determine the sanitary condition of the rural water supply services, by evaluating: a) drinking water quality; b) state of repair of the system's components; c) the quality or level of service; d) habits of hygiene; e) the state of the management or administration of the water supply system; and f) water-related diseases, in order finally to conclude with the rating of the service.

3. Rationale

There is ample literature on the way the conditions of the infrastructure affect the quality of drinking water. Defects and shortcomings in the infrastructure may be the result of bad design, bad construction (or construction supervision), or poor maintenance. They may also be caused by natural or human factors, such as earthquakes or social disruptions, which render the structures of the water supply system unable to protect and maintain the drinking water quality.

Another important factor is the community's attitude to the water supply system. In this reference, two fundamental and closely related components may be distinguished: a) the organization responsible for administering the water supply, and b) the response of the consumers. If the water supply service is to be sustainable, the community in question must have a functional organization in charge of managing and operating the supply system in such a way as to provide an adequate service. This organization will need to have individuals trained in administration, operation, maintenance and the communication of educational messages to the beneficiary population. The community must also be capable of recognizing the service received and making a fair payment for it. The tariffs paid by the consumers will serve to pay the members of the functional organization responsible for the administrative and/or technical tasks, as well as to purchase the inputs and materials necessary for the good operation and maintenance of the water supply system.

The quality of the supply service is another factor of great importance for the improvement of the beneficiary population's health. Ideally, the whole community should be served efficiently and effectively. However, it is often the case that the water supply service has limited coverage and/or very low continuity. This means that many of the population have to resort to other sources of water and/or store water to cover their basic needs, which results in the deterioration of the water quality and the consequent exposure of consumers to communicable water-related diseases.

Finally, it is considered that raising the level of hygiene of the beneficiary population is another factor conducive to improving their health. It is known that populations with poor habits of hygiene are more exposed to communicable diseases than those with better habits of hygiene. We have therefore included in the methodology for the surveillance of water quality in rural areas, the conduction of an evaluation of habits of hygiene as a means of identifying the hygiene education activities required to improve them.

4. Goals and Objectives

4.1 Main Goal

To set down the bases for implementation by the SANBASUR Project of a program for the surveillance of the quality of rural water supply services in the Cuzco Health Region, in order to determine the sanitary conditions of said services.

4.2 Specific Objectives

- a) To determine the quality of the water used for human consumption;
- b) to determine the quality of the water supply service;
- c) to determine the extent of deficiencies in the components of the water supply systems;
- d) to determine the habits of hygiene of the populations attended by the water supply services;
- e) to determine the state of the management of the water supply systems;
- f) to determine the prevalence of acute diarrheal diseases (ADD) and skin diseases; and
- g) to evaluate the water supply service.

5. Strategy

The objectives will be reached as follows:

- The quality of drinking water in the distribution system will be determined by physical, chemical, and bacteriological evaluation of the water, from the catchment to the home connection or community supply point (public standpipe or well).
- The quality of the service will be determined using two sets of survey questions, one set applied to the members of the Water Board and the other to the users of the water supply service.

- The condition and degree of conservation of the water supply infrastructure will be quantified by direct inspection of the main system components, to identify any defects that may affect the conservation of the drinking water quality.
- The habits of hygiene of the population benefiting from the water supply service will be determined by applying verification surveys to a number of consumers selected at random. The number of consumers to be surveyed will be defined by applying the sampling theory.
- Management of the water supply system will be assessed by analyzing the work done by each of the members of the Water Board.
- The prevalence of diarrheal diseases and skin diseases will be verified using surveys applied at random among the population served by the water supply system.
- The service quality will be scored based on a weighting of the indicators associated with the quality of the water and quality of the water supply service, among others.

The information will be gathered by applying five questionnaires, which cover the five fields of interest, namely: a) water quality and service quality; b) condition of the infrastructure; c) habits of hygiene and prevalence of acute diarrheal diseases and skin diseases; d) state of the management; and e) aspects connected with the community or populated center. The staff of the Peripheral Health Facilities of DESA-Cuzco will conduct these surveys.

6. Indicators

Corresponding to the objectives indicated above, the result indicators which will be obtained from the program for the surveillance of rural water supply services are: a) water quality; b) continuity, coverage and uses of the water (quality of service); c) state of conservation of the components of the water supply system; d) habits of hygiene; e) state of the management or administration; and f) acute diarrheas and skin diseases; being complemented with the rating of the water supply service.

6.1 Water Quality

Water distributed through the supply systems should be innocuous. To accomplish this, water quality must comply with the physical, chemical, and bacteriological standards set by the health authorities, to ensure that the water will not be harmful to consumers' health.

In the specific case of rural water supply systems, the analytical parameters were selected bearing in mind such aspects as: a) accessibility to the community, b) typical features of rural systems, and c) availability of economic, human, and material resources. It was considered appropriate that the water quality evaluation give priority to the testing of a group of basic parameters associated with water-borne diseases, as recommended by the World Health Organization, such as: turbidity, pH, chlorine residual, and thermotolerant (fecal) coliforms.

The tests will also include sporadic physical and chemical determinations, to build up a more complete picture of the quality of the water consumed by the rural population attended by

the community water supply services. It was also decided that the chlorine residual and pH determinations would be effected in the field; the turbidity and thermotolerant coliforms in the local laboratories, and the physical, chemical and metals analyses in the central laboratory. The determinations of chlorine residual and pH can be effected using colorimetric comparators and turbidity can be tested using nephelometric tubes.

6.2 *Quality of the Service*

Water supply systems must comply with the minimum requirements for which they were conceived and built. These minimum requirements are synthesized in satisfying the basic water supply needs of the community, within the concept of quality and its link to the preservation and conservation of the consumers' health.

In the present case, we have considered that the service quality can be assessed by determining the functional characteristics of the water supply system, such as a) coverage of the service; b) continuity of the water supply; and c) good use of the water supplied. This last factor can be interpreted as an indirect indicator of the amount of water consumed, which can be qualified in terms of "adequate consumption" or "wasteful consumption." Also, the potential extension capacity of the water supply system can be estimated taking into account the availability of water at the source.

6.3 *State of Repair of the Components of the Supply System*

Conservation of the quality of drinking water is dependent on the absence of physical defects in the components which make up the water supply system; as well as the availability of protective elements for the conservation of the water's physical, chemical, and bacteriological characteristics.

Observation of the condition and state of repair of the infrastructure is accomplished by sanitary inspection. The objective of the inspection is to identify possible defects in the components of the water supply system, and in the operational and maintenance practices which may imply risks for the conservation of the drinking water quality.

It was thought best that the evaluation of the level of deficiencies of the components of the water supply service should be effected for the four basic supply schemes, which have diverse and common aspects. The diverse aspects of each of the schemes are the types of source, catchment, or treatment, while the common aspect shared by the four is the distribution system itself.

The four water supply schemes considered are:

- Gravity-fed without treatment: catchment can be spring, filtration gallery, and direct supply;
- Gravity-fed with treatment: catchment and water treatment plant;

- Pumped, without treatment: water well and pumping equipment; and
- Pumped, with treatment: catchment, treatment plant, and pumping station.

With regard to the common aspects of the supply schemes, the following components have been considered: a) supply line/pipeline; b) air-vents or pressure-relief boxes; c) reservoirs; d) feeder main; e) distribution network; f) public standpipes; g) home connections.

The information provided or obtained in the course of the sanitary inspection work will make it possible to identify the measures required to correct any defects which may have been detected (associated with construction, operation, maintenance, or any other deviation from accepted standards of normal practice), in order to minimize the risk of contamination of water intended for human consumption.

6.4 *Habits of Hygiene*

Habits of hygiene are known to have a direct link with communicable diseases and it is also widely known that in populations with poor habits of hygiene the hygiene education programs contribute to improving the people's health. We can even affirm that the impact of hygiene education programs is far greater than that of the quality and quantity of the water supplied.

Improvement in the habits of hygiene of the populations with the greatest health problems is a slow process involving the permanent training of beneficiary populations to improve their customs until new good habits have gradually taken root. Constant practice over a long period is necessary, and this must be constantly evaluated and reinforced to ensure that the knowledge imparted in the training is first assimilated as a new attitude, and subsequently consolidated.

In this case, the habits with the greatest influence on the control of communicable diseases were selected, namely those linked with the handling of water, personal hygiene, the disposal of excreta, and hygiene in the home.

6.5 *Management of the Supply Services*

Recent studies have shown that the management or administration of rural water supply services has a strong influence on the conservation of drinking water quality. A weak management, which does not enforce the collection of a water tariff for the service rendered to the community, will be incapable of maintaining a person part-time or full-time for the proper operation and maintenance of the water supply service; and there will be no funds with which to purchase the spare parts or raw materials needed for efficient operation of the system or even for disinfecting the water.

In this context, it is indispensable that the following three basic aspects be evaluated: a) consistency of the water tariff; b) operation and maintenance; and c) payment of the operator. Tariff consistency is the relationship between: a) amount of the tariff; b) punctual payment; c)

existence of an operator for operation and maintenance of the system; and d) time the operator spends on his work.

6.6 *Diarrheal Diseases and Skin Infections*

Basic sanitation work seeks to improve the overall health of the beneficiary populations, and in particular to control to a greater or lesser degree the incidence of water-related communicable diseases. Surveillance of water quality in rural areas should therefore consider the periodic evaluation of cases of diarrhea and skin infections to identify their causes which, especially in the rural environment, may be linked with water quality and the habits of hygiene of the consumers.

In light of the economic constraints and the complexity of gathering data linked with cases of diarrhea and skin infections in each community, it was decided that for this project random surveys would periodically be conducted in consumers' homes in order to estimate the incidence of these diseases. The sampling theory will be applied to determine the number of homes where the surveys are to be applied, which will be evenly spread throughout the community being evaluated.

6.7 *Rating the Service*

To compare the quality of the service rendered by the water supply systems, it is planned to weight a certain group of indicators (mentioned above) in such a way that a score or rating can be given to the service being assessed. This score will make it possible to determine which supply services are the best ones and which are the least efficient. This information, in turn, will serve to prioritize the implementation of remedial measures for the improvement, rehabilitation or expansion of the water supply service in the worst affected or least efficient systems.

7. *Methods and Procedures*

7.1 *Prior Considerations*

Before embarking on the program of surveillance of rural water supply services it is necessary to define the unit, within the Executive Office of Environmental Health (DESA-Cuzco), responsible for implementing the program, the responsibilities of each one of its members, the furniture and supplies necessary for the office concerned, the equipment and chemical supplies needed for the central and peripheral laboratories, criteria for drinking water quality, manuals of procedures for surveillance of the rural water supply services, training programs and the information system, among other considerations.

- a) *Responsibilities:* It is assumed that DESA-Cuzco will be the head of the system of surveillance of quality of the rural water supply services in the Cuzco Health Region; and that the heads of Health Networks through the "micro-networks" and these, in turn, through the peripheral health posts and centers, will be responsible for gathering

information from the field. However, internal guidelines will need to be issued to specify the functions and responsibilities of each of the participants in the planned surveillance program. See Annex I.

- b) *Basic equipment:* At the central and district levels the minimum indispensable facilities are available for carrying out the surveillance of the quality of rural water supply services. Among the facilities available are: physical space, equipment (desks, computers, etc.). In the case of the present project, DESA-Cuzco has the required facilities and material.
- c) *Laboratories:* The central laboratory has several material resources appropriate to the level of surveillance planned for the region. In general terms, the laboratory materials available are:
- Furniture
 - Chemicals for physico-chemical analyses
 - Equipment and instruments
 - Culture media (bacteriological)
 - Glassware

The small district laboratories ("local laboratories") also have the facilities they need to perform the analyses for which they are responsible. The existing materials and those that need to be repaired or replaced at the level of each type of laboratory are shown in Annex II.

- d) *Water quality criteria:* The goal of the criteria for drinking water quality is to remove harmful factors or reduce the concentration of such parameters to below levels harmful to health, in order to contribute to the conservation of the health and well-being of the people served by the water supply system. Annex III gives the sampling parameters and frequency for evaluating the drinking water quality and the level of service in the present program.
- e) *Manuals of procedure:* In order to standardize the procedures for conducting the surveillance program, operation manuals will have to be distributed, in which the tasks of all those involved are clearly defined.

Gathering of information: In order to obtain information five forms have been designed: a) community registration; b) management and coverage; c) sanitary inspection and disinfection; d) water quality and Service quality; and e) habits of hygiene, diarrheal diseases and skin infections. Annex IV contains models of the forms and instructions for filling them out.

Sample collection and analysis: The sampling must be carried out by trained personnel to ensure that the water samples are representative of the supply system and that they will not be contaminated during the sampling and transportation processes. To that end, staff must be trained to comply strictly with the procedures of sampling, preservation, packing

and transportation of samples to the laboratory. They must also be trained to determine in the field the free chlorine content, pH and certain other types of information relative to the supply system. The staff in charge of this work must therefore be exclusive and enjoy the absolute trust of the surveillance office.

The sampling sites must be selected in such a way that they are representative of the water supply system.

Preferably, the sampling points will be:

- Outlets from springs
- Outlets from water wells
- Outlets from water treatment plants
- Outlets from components (storage or distribution tank, pressure-relief chambers, etc.)
- Pumphines and feeder mains
- Distribution network. The sampling points must be spread evenly throughout the distribution system and be proportional to the number of users, taking into account:
 - Sites of social responsibility such as: health centers, schools, places of mass food preparation, public standpipes.
 - Dead points, low pressure points or restricted supply points in distribution networks.

Annex V shows the sampling method to be applied in the present program.

With regard to the analyses to be carried out by the central laboratory, it is recommended that they follow universally accepted procedures, in order to guarantee the results of the analyses and render them comparable. It is recommended that the *Standard Methods for the Examination of Water and Wastewater* (APHA, AWWA and WEF, 1995) be adopted.

- f) *Training:* The training program must involve all tiers of the organization connected with the surveillance program, paying special attention to the formation of the staff responsible for field activities and information processing.

The quality of the information produced by the surveillance agency depends on the work carried out by the staff responsible for taking samples, conducting sanitary inspections, performing analyses, processing information, etc. For this reason the staff must be trained to do their work to a high standard. A good training program will ensure that the data and their processing will be standardized and comparable among the different generators of information, thereby facilitating systemization at the regional and national level. The training should be designed to prepare personnel in:

- Planning the task;
- Identifying the characteristics of the water supply services;
- Evaluations and identification of health risks;
- Collection and preservation of samples;
- Field analyses;

- Microbiological, physical and chemical analyses;
- Processing of information; and
- Interpreting and reporting results

Collecting information on the physical characteristics of the water supply systems, handling the forms, taking samples and performing field analyses require specific training, which must be both theoretical and practical.

Annex VI contains a model training program for staff in charge of field activities.

- g) *Information system:* The impact of the surveillance program is based on results and on the application of these results. It is therefore necessary to define how the information should flow from the evaluated community to the Regional Health Authorities, passing through the heads of the micro-networks and the heads of networks. Finally, the production of periodic reports on the conditions of the water supply systems and their principal defects should be considered as a final product. See Annex VII for a chart showing the information flow proposed for this project.

7.2 *Planning and Execution*

The activities involved in the work of surveillance of the quality of rural water supply services are:

- a) *Planning:* Before beginning its surveillance work, the surveillance agency must obtain general information about the communities it plans to work in: the type of water supply service they have, population size, public establishments – especially those relating to education and health – other basic services, and accessibility, in order to identify the facilities already existing in the community and which could be helpful in the surveillance work in general.

In addition, planning should include the definition of:

- Sampling frequency and number of analytical determinations required.
- Frequency of sanitary inspections.
- Sampling and analysis procedures.
- Accessibility.
- Establishments that form part of the information flow.
- Preparation of the database.

A list of the localities to be evaluated in the next three years, as well as the type and number of determinations to be performed, together with their cost, is shown in Annex VIII. Annex IX shows the number of determinations.

- b) *Execution*: After planning the different activities involved, the surveillance agency can proceed with its work. The following tasks have been defined: a) gathering information; b) sampling and testing; c) identifying corrective measures; d) analyzing information and e) reporting. See Annex IV.
- c) *Analysis of the information*: The analysis of the information will permit the rating of six basic aspects: a) drinking water quality; b) service quality; c) condition of the infrastructure; d) level of hygiene; e) system management; and f) prevalence of diarrheal diseases and skin infections. In addition, taking into account these six aspects, the service as a whole can be rated and given an overall score. The significance of the overall score is that it will enable the water supply systems to be compared with each other.

With reference to water quality, it will be classified in groups according to its origin, thus considering: a) outlet from the plant, spring or well; b) outlet from the intakes such as reservoirs and pressure-relief chambers in the distribution system; c) secondary distribution system and public standpipes; and d) storage containers within the home, if justified by circumstances.

- d) *Corrective measures*: After gathering the information and taking samples, the person in charge of field work will be in a position to identify the main problems in the water supply system that has been evaluated.

As a way of contributing to the community, the surveillance agency will distribute copies of its report on the principal defects encountered in the supply service to the administrator of the community Water Board and to the corresponding District Municipality. The community will then be able to apply remedial measures or seek support to improve its water supply service. Annex X contains a model of the report that will be given to the community listing the defects found in the course of the surveillance work.

7.3 *Quality Assurance of Data*

The data obtained by the surveillance personnel will be subject to validation to ensure accuracy. The evaluation of the performance of the persons responsible for field work is five-fold:

- Number of evaluations carried out;
- consistency of the results;
- number of direct supervisions;
- number of verifications in the field;
- quality of field work.

See Annex XI for the procedure to be carried out in assuring the quality of the data.

8. Bibliography

1. "Abastecimiento de Aguas y Disposición de Excretas" – Ministry of Health, Bureau of Environmental Health, Prevention and Control of Cholera - Colombia, 1991.
2. "Drinking Water Quality Control in Small Community Supplies" – Guidelines for Drinking Water Quality, Geneva, WHO, 1983.
3. "Control de Calidad del Agua en la Red de Distribución" HDT CEPIS 67 – September-December 1996.
4. "Seminar on the Control and Surveillance of Water Quality in Rural Communities – El Salvador: Ministry of Public Health and Social Assistance: National Program of Rural Basic Sanitation." – PAHO - Mexico D.F., 1995.
5. "Evaluation for village water supply planning" Sandy Cairncross, Ian Carruthers, Donald Curtis, Richard Feachem, G. Richard, David Bradley, George Baldwin. – Chichester, 1980.
6. "Informe del Programa de Vigilancia de la Calidad del Agua" – Ministry of Health – DEL AGUA- Peru, 1986.
7. "Interim evaluation of the WHO/UNEP drinking-water quality surveillance projects under implementation in the countries of Indonesia, Peru and Zambia" – Mauricio Pardo – DEL AGUA, 1987.
8. "Pilot Rural Water Surveillance project in Indonesia" – Barry Lloyd- Sri Suyati – January 1989.
9. "Propuesta de un Sistema de Información sobre Calidad de Agua y Saneamiento SICAS" – Jairo Niño Buitrago – Ministry of Health - Colombia, 1992.
10. "Surveillance of drinking water quality in rural areas" – Barry Lloyd, Richard Helmer – WHO, 1991.
11. "Vigilancia de los Servicios de Agua de Consumo Humano - Manual del Supervisor Secciones I, II y VIII" - Ministry of Health - Robens Institute - Peru, June 1990.
12. "Vigilancia y Control de Calidad del Agua: lo que Debemos Conocer y Hacer" MINSA-APRISABAC – Peru, 1989.

ANNEX 1
RESPONSIBILITIES

Among those involved in the surveillance of drinking water quality, we have the members of the community Water Board, the sanitary technicians or inspectors, the laboratory workers at the peripheral (local) level, the staff of the central laboratory, and the professionals responsible for rural surveillance. Their responsibilities are as follows:

Water Board: The members of the Water Board should accompany the sanitary technician or inspector to collect the water samples for analysis, verify that the field analyses are properly performed, provide any support required for the sanitary inspection, supply information about the management of the water supply system, and participate in the evaluation of habits of hygiene and determination of diseases prevalent in the community.

Sanitary inspector or technician: Following the plan drawn up by the surveillance agency, he/she should obtain the water samples from the water supply system using the prescribed procedures and placing particular emphasis on the catchment, the storage reservoir and home connections. He/she should also perform the basic determinations: pH, free chlorine residual and, if possible, turbidity.

The sanitary inspector or technician should participate, together with the members of the Water Board, in the sanitary inspection, the assessment of the administrative management of the water service, and the gathering of information on habits of hygiene, diarrheal diseases and skin infections. On completion of the evaluation of the system, the sanitary inspector or technician should write the inspection report listing the main problems detected during the inspection.

The sanitary inspector or technician should send the water sample(s) to the local laboratory, report the findings of the field analyses to the pertinent office, and send in all the completed questionnaires. Finally, once he/she has the results of the analyses reported by the local and central laboratories, he/she should proceed to notify the community of these findings, together with a list of the remedial measures to be implemented by the community Water Board in order to improve the water supply system.

Laboratory worker in the local laboratory: This worker is responsible for the determination of thermotolerant coliforms and turbidity, if circumstances call for it. It is his job also to send the water samples for physico-chemical and metal analyses to the central laboratory, and report the test results to the sanitary inspector or technician and the pertinent authorities. He should also prepare the flasks for the collection of bacteriological samples.

Central laboratory: The staff member responsible should perform the physico-chemical and metal analyses on the water samples sent in by the district laboratories and report the test findings to the pertinent authorities. He/she should also prepare the flasks for the collection of samples for the physico-chemical and metal analyses and send them to the local laboratories in good time.

Executive Office of Environmental Health (DESA-Cuzco): This office is responsible for periodically processing all the information sent in by the health services in charge of water

quality surveillance, and for identifying any corrective measures that need to be implemented by the communities and which may not have been observed by the field staff. This office also performs follow-up on the corrective measures and should report to national institutions and planning agencies on the condition and rating of the rural water supply services that have been assessed.

ANNEX 2

IMPLEMENTATION AND COMPLEMENTATION OF LABORATORIES

Table 1. Implementation and Complementation of Laboratories

Laboratory	Equipment available	Complementary equipment
Cuzco	<p>Microbiology area</p> <ul style="list-style-type: none"> • Bacteriological incubator • Dry sterilizers • Water still • Double boiler • Membrane filtration apparatus • Retorts • Analytical balance • Portable kit for bacteriological analyses <p>Physico-chemical area:</p> <ul style="list-style-type: none"> • pH meter • Spectrophotometer • Portable kit for physico-chemical analysis of water • Oven • Oximeter 	<p>Technical area</p> <ul style="list-style-type: none"> • Computer equipment <p>Microbiology area</p> <ul style="list-style-type: none"> • Laboratory materials and supplies <p>Physico-chemical area</p> <ul style="list-style-type: none"> • Fume hood • Turbidimeter • Laboratory materials and supplies
Quispicanchi	<p>Microbiology area</p> <ul style="list-style-type: none"> • Dry sterilizer • Bacteriological incubator • Double boiler • Water still • Portable filtration kit • Vertical retort • Analytical balance 	<p>Repair and calibration of analytical balance</p> <p>Laboratory materials and supplies</p>
Paruro	<p>Microbiology area</p> <ul style="list-style-type: none"> • Dry sterilizer • Bacteriological incubator • Double boiler • Water still • Portable filtration kit • Vertical retort • Analytical balance 	<p>Laboratory materials and supplies</p>
Chumbivilcas	<p>Microbiology area</p> <ul style="list-style-type: none"> • Dry sterilizer • Bacteriological incubator • Double boiler • Water still • Portable filtration kit • Vertical retort • Analytical balance 	<p>Laboratory materials and supplies</p>
La Convención	<p>Has no laboratory material or equipment</p>	<p>Microbiology area</p> <ul style="list-style-type: none"> • Dry sterilizer • Bacteriological incubator • Double boiler • Water still • Portable filtration kit • Vertical retort • Analytical balance

ANNEX 3

SAMPLING PARAMETERS AND FREQUENCIES

1. Introduction

For the Drinking Water Quality Surveillance Program to be implemented in the Cuzco Health Region, the SANBASUR Project, with the approval of the Executive Office of Environmental Health for Cuzco (DESA-Cuzco) - Ministry of Health, has selected a set of parameters to evaluate the quality of the drinking water.

2. Physical, Chemical, and Bacteriological Requirements

Tables 1 to 3 show the determinations to be adopted in the Program, as well as the acceptable concentrations.

3. Sampling Frequency

Tables 4 and 5 show the sampling frequencies specified for the source, the components of the water supply system, and the water distribution network.

4. Residual Chlorine

The presence of residual chlorine is not an indispensable requirement for the assessment of drinking water quality. However, its determination is considered a decisive element in the performance of the bacteriological analysis. To this effect, the determination of residual chlorine should be executed in different parts of the supply system at least once a month and during the collection of water samples for bacteriological analysis.

Table 1. Bacteriological Parameters

Sampling site	Coliforms (UFC/100 mL)	
	Total	Thermotolerant
Entrance to the distribution system ⁽¹⁾	0	0
In the distribution network ⁽²⁾	0	0

⁽¹⁾ 100% of the water samples analyzed during the year should indicate zero presence of total and thermotolerant coliforms.

⁽²⁾ 95% of the water samples analyzed during the year should indicate zero presence of total coliforms, although up to 10 total coliforms /100 mL sporadically in non-consecutive samples is accepted.

Table 2. Parameters that Affect Health

Parameter	Unit of measurement	Maximum concentration
Arsenic	mg/L as As	0.050
Cadmium	mg/L as Cd	0.010
Chromium	mg/L as Cr	0.050
Fluoride	mg/L as F	1.5
Mercury	mg/L as Hg	0.001
Nitrate	mg/L as NO ₃	45
Lead	mg/L as Pb	0.05

Table 3. Parameters that Affect Acceptability of the Water

Parameter	Unit of measurement	Maximum concentration	
		Recommended	Admissible
Turbidity	NTU	5	10
pH	pH unit	7.0 – 8.5	6.5 – 9.2
Aluminum	mg/L as Al	0.1	0.2
Calcium	mg/L as Ca	75	150
Zinc	mg/L as Zn	5.0	15.0
Chloride	mg/L as Cl	250	500
Copper	mg/L as Cu	0.05	0.5
Total hardness	mg/L as CaCO ₃	200	500
Iron	mg/L as Fe	0.1	1.0
Magnesium	mg/L as Mg	30	100
Manganese	mg/L as Mn	0.05	0.5
Sulphate	mg/L as SO ₄ ⁼	250	400
Total residual	mg/L	500	1,500

Table 4. Sampling Frequency (Treatment Plant, Groundwater Sources and Service Reservoirs)

Parameter	Type of water source	
	Ground	Surface
Coliforms	6 samples per year	
Turbidity pH	12 samples per year	
Arsenic Cadmium Chromium Fluoride Mercury Nitrate Lead	1 sample every two years	1 sample per year
Aluminum Calcium Zinc Chloride Copper Total hardness Iron Magnesium Manganese Sulphate Total residual	1 sample per year	2 samples per year

Table 5. Sampling Frequency (Distribution Network)

Parameter	Sampling frequency	Size of population (Inhabitants)	Number of samples per locality
Coliforms	6 samples per year	<200	1
Turbidity, pH and chlorine residual	12 samples per year	201 – 800	2
		801 – 2,000	3

5. Quality of the Water Supply Service

The rural water supply services will be periodically evaluated with the frequency indicated in Table 6.

Table 6. Frequency of Evaluation

Activity/field	Form	Frequency
Community registration	M-1	Once only
Management and coverage	M-2	Quarterly
Sanitary conditions of the water supply infrastructure	M-2	Every two months
Water quality and service quality	M-4	Every two months
Habits of hygiene and presence of diseases in the community	M-5	Quarterly
Habits of hygiene in the school population	M-6	Quarterly

ANNEX 4

ASSESSMENT OF THE WATER SUPPLY SERVICE (Miscellaneous Forms and Instructions for Filling Them Out)

The SANBASUR Project, with the approval of the Executive Office of Environmental Health for Cuzco (DESA-Cuzco) - Ministry of Health, has defined the aspects to be assessed, as follows:

- Registration of the community;
- management and coverage;
- sanitary condition of the water supply infrastructure;
- water quality and service quality;
- habits of hygiene and presence of diseases in the community;
- habits of hygiene in the school population.

Registration of the community: This information is obtained by applying Form M-1, which should be done at the outset of work in the community, and subsequently any time that a substantial change in its characteristics is observed. The replies are obtained by direct observation or by asking the community authorities.

Management and coverage: This information is collected by applying Form M-2 every three months. The questions are asked of the members of the community Water Board.

Sanitary condition of the water supply infrastructure: The sanitary inspections will be conducted every two months and should coincide with the collection of samples for analyses of thermotolerant coliforms, pH and turbidity. Form M-3 is used for this, and the data are gathered by the inspector jointly with the operator and the members of the Water Board.

Water quality and service quality: For this assessment Form M-4 is applied every two months. This work is performed jointly with the operator and the members of the Water Board.

Habits of hygiene and presence of diseases in the community: These data are obtained using Form M-5 and the frequency of gathering this information is quarterly. Most of the questions are replied to by direct observation.

Habits of hygiene in the school population: The data are obtained by applying Form M-6, quarterly as in the previous case.

COMMUNITY REGISTRATION FORM

1. Location

Community _____ **CODE** _____
 Annex/Sector _____ District _____
 Province _____ Department _____
 Total Population _____ Number of families _____
 Health facility for referral _____

2. Accessibility

From	To	Distance (km)	Time (Hours)	Type of Road ⁽¹⁾	Means of Transportation ⁽²⁾

⁽¹⁾ **Paved local road, packed dirt road, trail.**

⁽²⁾ **Vehicle, pack animal, on foot.**

3. Additional Basic Services

Electricity Telephone Phone number _____
 Radio Radio frequency _____

4. Schools

Pre-school Elementary High school

Others: _____

Date: _____

Name of survey conductor: _____

Signature _____

FORM M-2

FORM TO ASSESS MANAGEMENT AND COVERAGE

1. Location

Community _____ **CODE** _____
 District _____ Province _____

2. Management

2.1 Responsible for administration of the water service

Community Water Board Municipality Community Leaders
 Others _____

Duration of position (as per bylaws) _____ years

How long in office? _____ years

2.2 Revenues

Amount of payment for water service	S/.	Period	Number of connections
-------------------------------------	-----	--------	-----------------------

Home connection	_____	_____	_____
-----------------	-------	-------	-------

Public standpipes	_____	_____	_____
-------------------	-------	-------	-------

Tariff in force for _____ years

2.3 Punctuality

Percentage of consumers who pay punctually for the water service _____ %

2.4 Extraordinary contributions

Do consumers made an extraordinary contribution? Yes No

2.5 Operation and maintenance

Does the service have an operator/plumber/other? Yes No

If so, how much time does he spend on the service?

Full time As required Part time

2.6 Administration costs (per month)

Administration (members of management unit) S/. _____

Operators S/. _____

Materials

Chlorine S/. _____

Piping, glue, accessories S/. _____

3. Coverage

Number of housing units _____

Number of home connections _____

Number of public standpipe connections _____

Number of homes not supplied _____

Date: _____

Name of survey conductor: _____ Signature _____

FORM TO ASSESS THE SANITARY CONDITION OF THE WATER SUPPLY INFRASTRUCTURE

1. Location

Community _____ Code _____
 District _____ Province _____

2. The Drinking Water System

Age Executing Agent
 Operation: Continuous Restricted

3. Type of Supply System

Gravity-fed without treatment Gravity-fed with treatment
 Pumped without treatment Pumped with treatment

4. Source

In times of drought can more be supplied? YES NO

Groundwater			G w/o T	G w T	P w/o T	P w T
Spring water, intake in the spring	<input type="checkbox"/>	Answer question 4.1	x			
Deep well	<input type="checkbox"/>	Answer question 4.2				
Sub-surface water (filtration gallery)	<input type="checkbox"/>	Answer question 4.3	x		x	
Surface water with treatment	<input type="checkbox"/>	Answer question 4.4		x		x

4.1 Intakes and Water Reunion Boxes Number of: intakes water reunion boxes

Characteristics	Intakes			Reunion Boxes		
	1	2	3	1	2	3
Is there a protecting fence?						
Is there a surface water diversion ditch, and is it in good condition?						
Is there a lockable sanitary lid in good condition?						
Is the structure in good condition and without cracks or leaks?						
Is the inside of the structure clean and free from foreign matter?						
Absence of puddles of water or fecal matter within a 20-m radius?						
Sample Code						

4.2 Deep Well Drilled Dug Depth m

Does it have housing and is it protected against entry of people and/or animals?	
Is the pump mounted on an uncracked concrete slab, more than 4 m in diameter?	
Is the mouth of the well above the level of the concrete slab?	
Absence of puddles of water or fecal matter within a 20-m radius?	
SAMPLE CODE	

4.3 Filtration Gallery and Water Reunion Boxes

Number of water reunion boxes

Characteristics	Gallery	Reunion Boxes		
		1	2	3
Is there a protecting fence?				
Is there a lockable sanitary lid, in good condition?				
Is the structure in good condition and without cracks or leaks?				
Is the inside of the structure clean and free from foreign matter?				
Absence of puddles of water or fecal matter within a 20-m radius?				
SAMPLE CODE				

4.4 Surface Water with Treatment

SOURCE: Stream <input type="checkbox"/> Lake/lagoon <input type="checkbox"/> River <input type="checkbox"/> Gully <input type="checkbox"/> Other <input type="checkbox"/>	
SUPPLY: Pumped <input type="checkbox"/> Gravity-fed <input type="checkbox"/>	
Treatment Processes: Flocculation <input type="checkbox"/> Sedimentation <input type="checkbox"/> Pre-filtering <input type="checkbox"/> Filtering <input type="checkbox"/>	
Is there a protecting fence?	
Are the treatment structures free from risk of accidental flooding?	
Is the structure in good condition and without cracks or leaks?	
Is the inside of the structure clean and free from foreign matter?	
Absence of puddles of water or fecal matter within a 20-m radius?	
SAMPLE CODE	

5. Conduction System

5.1 Conduction Line / Pumpline	
Absence of leaks?	
Is the whole length of the pipeline underground?	
Are the above-ground crossings protected and in good condition?	

5.2 Air-vents and Pressure-Relief Boxes in the Conduction Line	Air Vent			P.R.B.		
	1	2	3	1	2	3
Is there a lockable sanitary lid, in good condition?						
Is the structure in good condition and without cracks or leaks?						
Absence of puddles of water or fecal matter within a 20-m radius?						

6. Distribution System

6.1 Reservoir		1	2
Is there a protecting fence?			
Is there a lockable sanitary lid, in good condition?			
Is the structure in good condition and without cracks or leaks?			
Is the inside of the structure clean and free from foreign matter?			
Absence of puddles of water or fecal matter within a 20-m radius?			
Sample Code			

6.2 Feeder Main	
Absence of leaks?	
Is the whole length of the pipeline underground?	

6.3 Pressure-Relief Boxes	1	2	3	4
Is there a lockable sanitary lid, in good condition?				
Is the structure in good condition and without cracks or leaks?				
Absence of puddles of water or fecal matter within a 20-m radius?				

6.4 Distribution Network	
Absence of leaks?	
Is the whole length of the pipeline underground?	
Are the valve boxes dry?	

6.5 Public Standpipes	PP1	PP2	PP3	PP4	PP5
Is the structure in good condition and without cracks or leaks?					
Is the structure clean?					
Are the accessories and/or tap complete and in good condition?					
Absence of puddles of water or fecal matter within a 20-m radius?					

7. Chlorination

Frequency of water chlorination: Always <input type="checkbox"/> Sometimes <input type="checkbox"/> Never <input type="checkbox"/>	
Is chlorination equipment available?	
Is the equipment in good condition?	
Is the equipment in use at the time of the visit?	
Is there a stock of chlorine?	

Date: _____

Name of survey conductor: _____

Signature _____

FORM M-4

FORM FOR COLLECTING WATER SAMPLES AND ASSESSING THE QUALITY OF THE SERVICE

1. Location **Code** _____

Locality _____ District _____
 Province _____ Department _____

2. Samples

2.1 Distribution network

Home	Address	Name of user	Time of sampling	Chlorine residual	Number of sample ⁽¹⁾	
					pH / turbidity	Coliforms
1						
2						
3						
4						
5						
6						

2.2 Components

No	Type ⁽²⁾	Time of sampling	Chlorine residual	Number of sample ⁽³⁾			
				pH / turbidity	Coliforms	Physico-chemical	Metals
1							
2							
3							

- (1) To be carried out by the local laboratory.
- (2) Intake, reservoir, pressure-relief chamber, etc.
- (3) Analysis of pH, turbidity and coliforms to be performed by the local laboratory, and physico-chemical and metals analyses by the central laboratory.

3. Quality of the Service

Home	Continuity		How the water is used			Home connections		Condition of tap (leaking?)	
	Hours/day	Days/week	Domestic	Watering streets	Watering veg. gardens	Leaks	Water has formed pools	Yes	No
1									
2									
3									
4									
5									
6									

Date: _____

Sampler: _____

Signature: _____

Habits of Hygiene	1	2	3	4	5	6	7	8	9	10	11	12	13	14	15	16	17	18	19	20
6. Presence of Diseases (past two weeks)																				
6.1 ADD																				
6.1.1 Cases of ADD in under-five-year-olds? (Number)																				
6.1.2 Cases of ADD in over-fives? (Number)																				
6.2. Skin diseases (SD)																				
6.2.1 Skin diseases in under-five-year-olds? (Number)																				
6.2.2 Skin diseases in over-fives? (Number)																				

* Large animals: cattle, pigs, goats, sheep, horses and mules.

Date: _____ Name of sampler: _____ Signature: _____

FORM TO VERIFY HABITS OF HYGIENE IN THE SCHOOL POPULATION

Code _____ Community/Annex/Sector _____ School _____ District _____ Province _____

School Children	1	2	3	4	5	6	7	8	9	10	11	12	13	14	15	16	17	18	19	20
1. Personal Hygiene																				
1.1 Are the children clean?																				
1.2 Are they wearing clean clothes?																				
2. Hand-Washing																				
2.1 Are their hands clean? (check)																				
2.2 Do they wash their hands under running water? (check)																				
2.3 Do they wash their hands before school breakfast?																				
2.4 Do they use soap or ashes to wash their hands? (check)																				
2.5 Do they wash their hands after using the latrine?																				
3. Use of Toilets or Latrines																				
3.1 Do the children use the toilet or the latrine?																				
4. School																				
4.1 Does it have a toilet or latrines?																				
4.2 Are they working?																				
4.3 Is the toilet or latrine clean?																				
4.4 Are the classrooms clean?																				
4.5 Absence of fecal waste in the vicinity of the school?																				
5. Garbage Disposal																				
5.1 Do they bury the garbage?																				
5.2 Other forms of garbage disposal (not scored)																				
• River																				
• Field																				
• Burning																				
Total Score																				

Note: In a school population of more than 100 students, the survey is applied to 20%.

Date: _____ Name of sampler: _____ Signature: _____

INSTRUCTIONS ON FILLING OUT THE FORMS

FORM M-1

COMMUNITY REGISTRATION FORM

1. Location

- Code:** Insert the number assigned by the Surveillance Agency to the community, annex, or sector.
- Community:** Indicate the name of the community.
- Annex/Sector:** Indicate whether it is an annex or sector.
- District:** Indicate the district to which the annex or sector belongs.
- Province:** Indicate the province where the district is located.
- Department:** Indicate the department to which the province belongs.
- Total population:** Note the total population of the locality.
- Number of families:** Indicate the number of families living in the community.
- Health facility for referrals:** Note the name of the health facility whose jurisdiction the community comes under.

2. Accessibility

- **From:** First insert the name of the referral health facility, and in the following lines the answer to TO appearing in the line above.
- **To:** Write the name of the geographic place where there is a change in the type of road or means of transportation.
- **Distance:** Corresponding to the stretch indicated in the row.
- **Time:** Idem.
- **Type of Road:** Indicate which type of road the stretch can be described as: Paved, packed dirt road trail.
- **Means of Transportation:** Indicate how one can travel along that stretch: Vehicle, pack animal, or on foot.

3. Additional Basic Services

- Put an X in the appropriate box.
- **Telephone:** If there is a telephone, note the number.
- **Radio:** If there is radio in the locality, note the radio frequency.

4. Schools

- Mark with an X the type of school.
- **Others:** Indicate any other type(s) of school existing in the locality apart from the three mentioned.

Write the date, and the name of the survey conductor. He/she should sign the form in the space provided.

FORM FOR ASSESSING MANAGEMENT AND COVERAGE

1. Location

- Code:** Insert the number assigned by the Surveillance Agency to the community, annex, or sector.
- Community:** Indicate the name of the community.
- Annex/Sector:** Indicate whether it is an annex or sector.
- District:** Indicate the district to which the annex or sector belongs.
- Province:** Indicate the province where the district is located.

2. Management

2.1 *Responsible for Administration of the Water Service*

- Mark with an X the institution responsible for administration of the water service.
- **Duration of position:** Indicate the number of years stipulated in the administration bylaws.
- **How long in office:** Indicate the number of years that those responsible for the administration of the water service have been in office.

2.2 *Revenues*

- In each line indicate in the columns corresponding to home connections or public standpipes, the following data: the amount in Soles paid for the water services; how many months the water payment covers (monthly, quarterly, etc.); and the number of connections existing in the community.
- **Tariff in force for:** Indicate for how many years the water service tariff has been in force.

2.3 *Punctuality*

- Indicate the percentage of consumers who pay the water tariff punctually.

2.4 *Extraordinary Contributions*

- Mark with X the appropriate box if the consumers make extraordinary contributions.

2.5 *Operation and Maintenance*

- Indicate whether the water supply service has a person in charge of operation and maintenance.
- Indicate the time spent by the operator attending to the water supply service.

- Full time: Indicate that the operator works the equivalent of a full working day every day of the week.
- As required: The operator is required only when there is the need for a specific task to be done.
- Part time: The operator works only some hours every day.

2.6 *Administrative Costs (monthly)*

Administration: Indicate the monthly sum paid, only if one or more members of the Water Board receives payment.

Operator: Indicate the monthly amount paid to the operator.

Material: Indicate the amount spent during the month on the purchase of chlorine, or for materials used making new connections or repairing the water distribution network.

3. Coverage

- Indicate the number of houses, home connections, public standpipes, and homes not attended by the water supply service. Make sure that the sum of the last three equals the number of houses existing in the locality.

Write the date, and the name of the survey conductor. He/she should sign the form in the space provided.

FORM M-3

**FORM FOR ASSESSING THE SANITARY CONDITION OF THE
WATER SUPPLY INFRASTRUCTURE**

1. Location

- Code:** Insert the number assigned by the Surveillance Agency to the community, annex, or sector.
- Community:** Indicate the name of the community.
- Annex/Sector:** Indicate whether it is an annex or sector.
- District:** Indicate the district to which the annex or sector belongs.
- Province:** Indicate the province where the district is located.

2. The Drinking Water System

- **Age:** Indicate how many years ago the water supply system was built.
- **Executor:** Indicate the institution or organization that built the water supply system.
- **Operation:** Indicate whether the water supply system works continuously or is restricted because of cuts in the supply or lack of water.

3. Type of Supply System

Mark with X the corresponding box.

4. Source

- Indicate whether in time of drought the source is capable of producing more water than the locality needs. This can be observed by seeing how the overflow pipe works at the intake.
- Depending on the type of water supply system, use the appropriate groups of questions.

4.1 *Intakes and Water Reunion Boxes*

- Indicate the number of intakes and water reunion boxes.
- For each question about the characteristics of the intakes and water reunion boxes, answer YES or NO as appropriate.

4.2 *Deep Well*

- Indicate the type of well that is being assessed (drilled or dug), as well as its depth in meters.
- For each question about the characteristics of the water well, answer YES or NO as appropriate.

4.3 *Filtration Gallery and Water Reunion Boxes*

- Indicate the number of water reunion boxes.

- For each question about the characteristics of the filtration gallery and water reunion boxes, answer YES or NO as appropriate.

4.4 Surface Water with Treatment

- Indicate the type of water supply source: Stream (a small water course), lake, lagoon, river, gully . If it is any other type, indicate in the space provided.
- Indicate whether the water is supplied to the treatment plant by pumping or by gravity.
- For each question about the characteristics of the treatment plant, answer YES or NO as appropriate.

5. Conduction System (conduction line, and air-vents and pressure-relief box in the conduction line)

For each question about the characteristics of the conduction system, answer YES or NO as appropriate.

6. Distribution System (reservoir, feeder main, pressure-relief boxes, distribution network and public standpipes)

For each question about the characteristics of the distribution system, answer YES or NO as appropriate.

7. Chlorination

- Indicate whether the water is chlorinated permanently, sometimes, or whether it is not customary to disinfect the water.
- For each question about the characteristics of the chlorination system, answer YES or NO as appropriate.

Write the date and the name of the survey conductor. He/she should sign the form in the space provided.

**FORM FOR COLLECTING WATER SAMPLES AND ASSESSING
SERVICE QUALITY**

1. Location

- Code:** Insert the number assigned by the Surveillance Agency to the community, annex, or sector.
- Community:** Indicate the name of the community.
- Annex/Sector:** Indicate whether it is an annex or sector.
- District:** Indicate the district to which the annex or sector belongs.
- Province:** Indicate the province where the district is located.

2. Samples

2.1 Distribution network

- For each of the homes, fill in the house address and name of the person surveyed.
- **Time of sampling:** Indicate the time the sample was taken.
- **Chlorine residual:** Note the concentration of chlorine residual found in the water of the evaluated home.
- **Number of sample:** Note the number of the sample and of the flask containing the sample which will be sent to the local laboratory for testing.

2.2 Components

- **Type:** Note the name of the structure where the sample was taken, for example, intake, pressure-relief chamber, etc.
- **Time of sampling:** Indicate the time the sample was taken.
- **Chlorine residual:** Note the concentration of chlorine residual found in the water of the evaluated component.
- **Number of sample:** Note the number of the sample and of the flask containing the sample which will be sent to the local laboratory, and the central laboratory if necessary, for testing.

3. Quality of the Service

- For each of the homes indicated previously, note the answers regarding continuity, how the water is used, condition of the tap(s) and condition of the home connection.
- **Continuity:** Note the hours per day and the days per week that the household is supplied with water.
- **How the water is used:** Indicate the main use given to the water supplied by the system.
- **Condition of the tap:** Note whether or not the tap is leaking.
- **Home connections:** Note whether in the home connection box the pipe shows signs of leaking and/or whether the box is full of water.

Write the date, and the name of the survey conductor. He/she should sign in the space provided.

FORM M-5

**VERIFICATION OF HABITS OF HYGIENE AND PRESENCE OF
DISEASES IN THE COMMUNITIES**

- Community:** Indicate the name of the community.
- Code:** Insert the number assigned by the Surveillance Agency to the community, annex, or sector.
- Annex/Sector:** Indicate whether it is an annex or sector.
- District:** Indicate the district to which the annex or sector belongs.
- Province:** Indicate the province where the district is located.

- **House:** Note the address of the house.
- **Water:** For each question answer YES or NO, as appropriate.
- **Personal hygiene:** For each question answer YES or NO, as appropriate. In item 2.2.3 indicate the number of times they wash their hands each day.
- **Latrines:** For each question answer YES or NO, as appropriate.
- **House:** For each question answer YES or NO, as appropriate.
- **Garbage disposal:** Answer YES or NO, as appropriate.
- **Presence of diseases:** Indicate the number of cases of diarrheal diseases and skin infections that occurred in the house during the previous two weeks.

Write the date, and the name of the survey conductor. He/she should sign the form in the space provided.

FORM M-6

VERIFICATION OF HABITS OF HYGIENE IN THE SCHOOL POPULATION

School: Indicate the name of the school.
Community: Indicate the name of the community.
Annex/Sector: Note whether it is an annex or a sector.
District: Indicate the district to which the annex or sector belongs.
Province: Indicate the province where the district is located.
Code: Note the number assigned by the Surveillance Agency to the community, annex or sector.

- **Children:** Indicate the name and year of studies.
- **Personal hygiene:** For each question answer YES or NO, as appropriate.
- **Hand-washing:** For each question answer YES or NO, as appropriate. In item 2.3 indicate the number of times they wash their hands each day.
- **Presence of diseases:** Indicate the number of cases of diarrheal diseases and skin infections that occurred in the house during the past two weeks.
- **Latrines:** With reference to the latrine(s) existing in the school, for each question answer YES or NO, as appropriate.
- Use one column per latrine.
- **School:** For each question answer YES or NO, as appropriate.
- **Garbage disposal:** Answer YES or NO, as appropriate.

Write the date, and the name of the survey conductor. He/she should sign the form in the space provided.

ANNEX 5

SAMPLE COLLECTION AND PRESERVATION, AND REPORTING OF FINDINGS

1. Introduction

One of the main components of the surveillance of drinking water quality is the evaluation and characterization of the water supplied to the people. Evaluation and characterization of the water are carried out by analyzing the water samples obtained from the supply system.

This Section is concerned with different aspects of the sampling process, and the special care that must be taken from the time the sample is collected up to its arrival at the laboratory. We also include model laboratory analysis reports.

The collection and transportation of samples must comply with the following requisites:

Planning the Sampling

Perform the sampling as frequently as recommended by the Sanitary Authorities.

Sampling Sites

Select the sampling sites so that the samples obtained will be representative of the water flowing through the supply system.

Be Careful

Do not contaminate the water sample while taking the sample or during transportation.

Taking the Sample

Take an adequate volume of the sample in flasks appropriate for the laboratory.

Preservation

Protect the water sample from any significant change in its composition before its analysis.

Identification

Clearly describe the details of the sampling on the cards accompanying the flasks with the water samples.

Packing and transportation

Pack the water samples properly to avoid breakage of the containers or contamination of the contents, and send them as soon as possible to the laboratory for analysis.

The criteria for taking a sample for bacteriological analysis should take into account the concentration of free chlorine and turbidity as indicated in Figure 1.

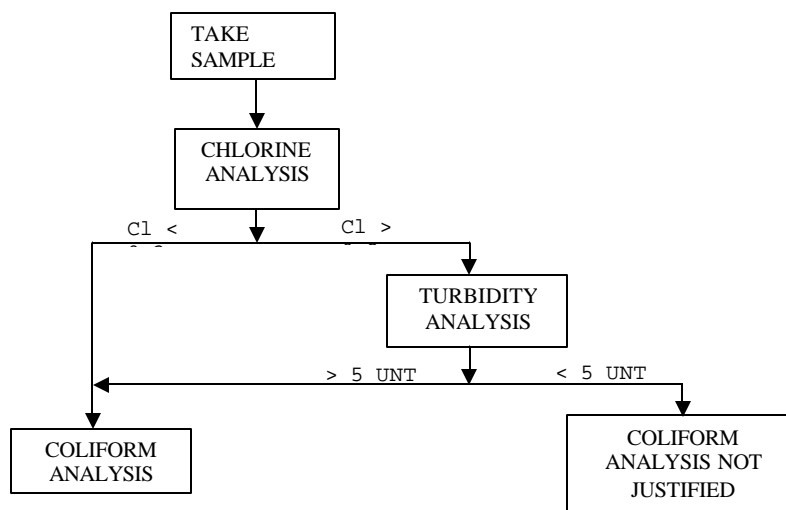

Figure 1. Criteria for Decision on Testing for Coliforms

2. Containers and Volumes

When taking water samples for analysis, care must be taken in a number of aspects, according to the type of sample.

a) *Bacteriological*

The bottle, jar or flask for bacteriological samples must be sterilizable, preferably of glass, with a wide mouth, a securely closing cap or stopper and capacity of no less than 120 mL.

These sample bottles must be carefully washed and thoroughly rinsed so that no residue remains of the chemical substances used in washing. Before the sterilization process the bottles must be drained of all water; once dry, add 2 or 3 drops of sodium thiosulfate at 10%, then place a strip of kraft paper between the cap and the neck of the bottle to prevent its getting stuck later. Also, in order to preserve it from external contamination and the introduction of foreign matter during handling, transportation and sampling, place a protective kraft paper sleeve over the mouth, tying it in place with a piece of cord or string (see Figure 2).

Once the bottle has been prepared as described above, proceed to sterilize it in a hot air oven at 160 °C for two hours or by autoclaving it at 121 °C for 20 minutes.

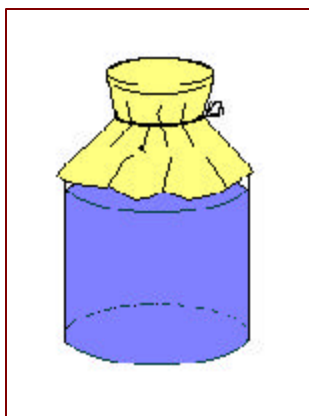

Figure 2. Sample Bottle

b) Physical

The sample containers used in this group of analyses can be plastic (polyethylene or polypropylene) or glass, of half-liter capacity.

These bottles must be washed carefully with a solution of detergent and rinsed with abundant water. Then add a solution of hydrochloric acid 1+1 and rinse again with abundant water. The final rinse is with distilled or de-ionized water. After the final rinse, drain the bottle and put the stopper on.

c) Chemical

The sample containers used in this analysis group can be plastic (polyethylene or polypropylene) or glass, of one-liter capacity. The washing procedure is similar to the previous one, except that the cleaning with hydrochloric acid must be even more thorough.

For the type of preservation of the samples, the sample should be divided into two parts. The first part is for the determination of:

- | | | |
|-------------|-------------|------------------|
| - Calcium | - Chlorides | - Total hardness |
| - Magnesium | - Sulfates | - Total residual |
| - Fluoride | - Nitrate | - pH |
| - Turbidity | | |

The second flask is for the analysis of:

- | | | |
|------------|-------------|-----------|
| - Aluminum | - Zinc | - Copper |
| - Iron | - Manganese | - Arsenic |
| - Cadmium | - Chromium | - Mercury |
| - Lead | | |

3. Selection of Sampling Sites in the Network

The objective of the sampling is to determine the “quality of the water in the supply system,” whether it be in the components or the user’s faucet or at some other outlet of water destined for human consumption.

The sampling points selected in the distribution network must therefore be such as to ensure that the samples are representative of the existing water supply; points inside homes that have private storage should be discarded. The general criteria to keep in mind in selecting the sampling points are that they must:

- Be representative of the supply system as a whole and its principal components.
- Represent *the quality of the different sources of water supply*. The sampling points should be located immediately outside the outlet from the treatment plant or water well.
- Represent the conditions of the least favorable places in the system from the point of view of possible contamination.
- Be spread evenly throughout the length and breadth of the water supply system.
- Consider the presence of the different components (storage tanks and/or pumping chambers).
- Take into account the number of inhabitants served by the supply system.
- The sampling points are selected according to the type of distribution system, which could be open, closed or mixed.
- In open distribution systems, the most representative sampling points are those shown in Figure 3.
- Likewise, in closed distribution systems the sampling points to be emphasized are those shown in Figure 4.
- Finally, in mixed distribution systems the sampling points are selected as shown in Figure 5.

In addition, the following aspects must be considered:

- a) Critical points of the system such as areas with old networks, areas with a history of continual breakage, areas with low pressure, or areas exposed to frequent flooding.
- b) Areas with a high population density.
- c) Supply points for tank trucks and individual collection.

- d) Food industry areas.
- e) Emergency areas.
- f) Areas used for recreation or mass meetings.

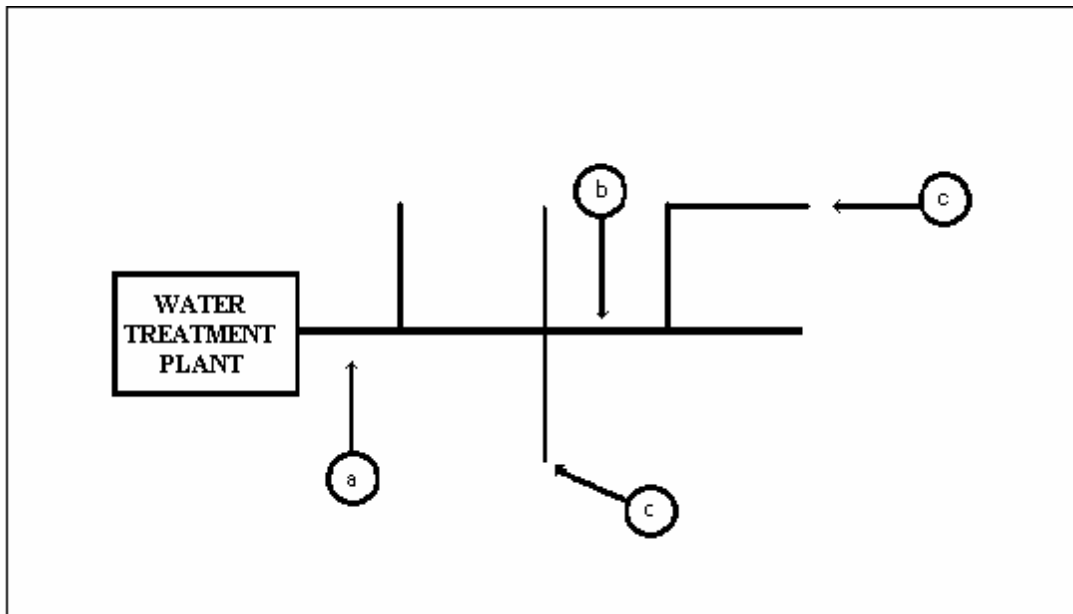

Figure 3. Sampling Sites in Open Distribution Systems

- (a) At the outlet of the water treatment plant. Indicates the quality of the water entering the distribution system.
- (b) At an intermediate point, to be representative of the water in the mains.
- (c) At one or more points that are representative of the water at the ends of the distribution network.

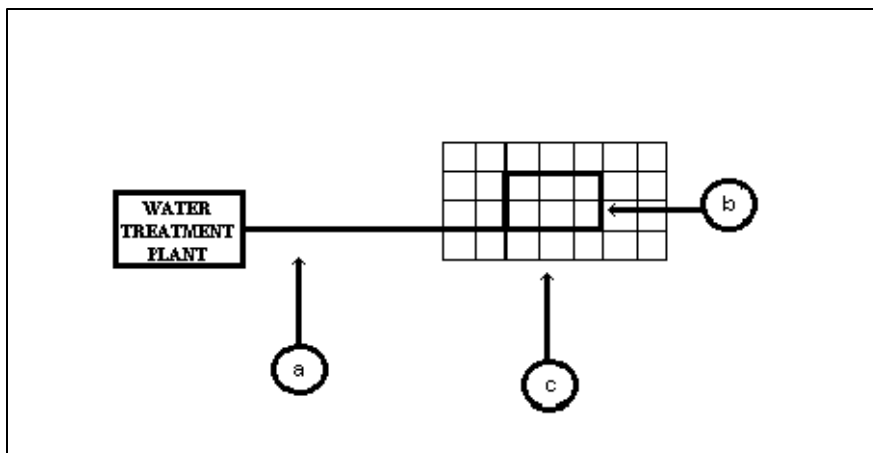

Figure 4. Sampling Sites in Closed Distribution Systems

- (a) At the outlet of the water treatment plant. Indicates the quality of the water entering the distribution system.
- (b) At a point representative of the water in the main circuit.
- (c) At points that are representative of the water in the secondary circuits or at the end of the water distribution network.

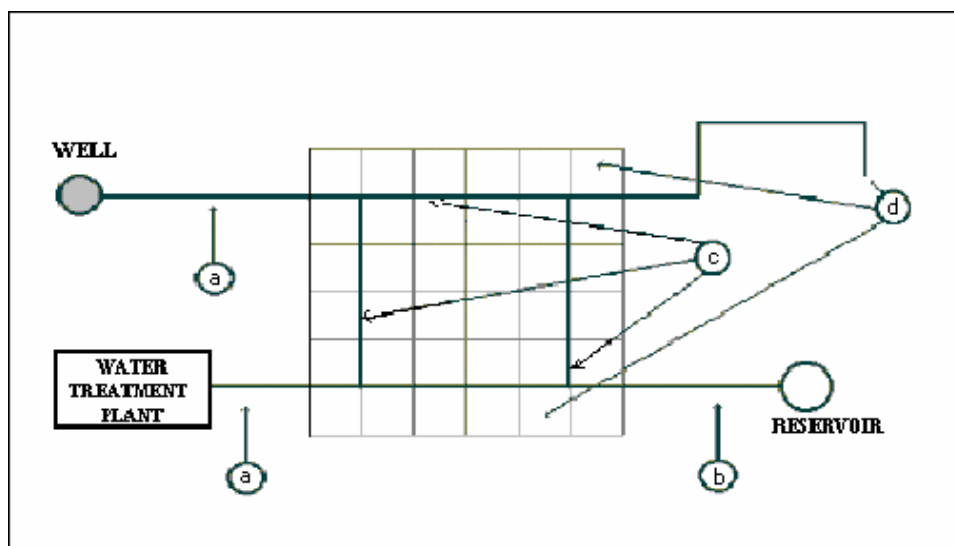

Figure 5. Sampling in Mixed Distribution Systems

- (a) At the outlet of the treatment plant and/or water wells. Indicates the quality of water entering the distribution system.
- (b) At the outlet of the storage components.
- (c) At points representative of the water in the main circuit.
- (d) At points representative of the water in the secondary circuits or at the end of the water distribution system.

4. Sample Collection

General

The collecting or taking of a sample depends on the types of structures or sampling points. These can be classified as follows:

Components

- Reservoirs
- Cisterns

Distribution network

- Home connections (direction connection to the network)
- Public standpipes

Dug wells

Springs

Procedures

Precautions are taken in keeping with the type of analysis. The procedures can therefore be described as follows:

Bacteriological

a.1 Components (Reservoirs, Cisterns and Home Storage)

Cleaning

Remove any type of residual found around the lid of the component with a brush.

Removal of the Lid

Remove the lid carefully, taking care that no type of residual falls into the component.

Opening of the Sterilized Flask

Untie the string that holds the protecting paper sleeve in place, remove the sleeve and unscrew the top.

Sterilization

Using a flame lit on a wad of absorbent cotton soaked in alcohol, sterilize the external part of the sample flask.

Taking of the Sample

After the flask has cooled, very carefully submerge it in the mass of water, to a depth of approximately 20 cm.

Replacing the Stopper

Before replacing the stopper, pour off a small amount of water to leave an air space which will facilitate sample shaking (mixing) at the analysis stage.

Then replace the stopper on the flask and cover with the protecting kraft paper sleeve. Tie this in place with the string.

a.2 Distribution Network (Home connections and public standpipes)

Cleaning the Faucet

Remove from the faucet any material adhering to it that could cause splashing. Carefully clean the mouth of the faucet with a clean cloth to remove any dirt or grease.

Washing out the Faucet

Open the faucet to its maximum flow and let the water run for 1-2 minutes.

Sterilization

Before taking the water sample, close the faucet and sterilize it for one minute with the flame from a piece of absorbent cotton soaked in alcohol. As an alternative, a gas flame or a lighter can be used.

Draining the Faucet before Sampling

Open the faucet carefully and allow the water to flow slowly for 1-2 minutes more, at a speed suitable for filling the sample flask easily.

Opening the Sterilized Flask

Untie the string that is holding the protecting paper sleeve in place, and remove the paper sleeve.

Taking the Sample

Remove the stopper or unscrew the cap and, while holding it in one hand, immediately put the flask under the flow of water and fill it. Leave a small air space to facilitate shaking at the analysis stage.

Sealing the Flask

Replace the stopper on the flask or screw on the cap. Tie the protective paper sleeve in place with the string.

a.3 Dug Wells

Placing the Extension

Around the neck of the bottle or flask tie a clean string wound onto a stick.

Opening the Sterilized Flask

Untie the string that holds the protecting paper sleeve in place, take off the sleeve and unscrew the cap.

Sterilization

Using a flame lit on a piece of absorbent cotton soaked in alcohol, sterilize the outside of the sample flask.

Taking the Sample

After the flask has cooled, lower it carefully into the well, slowly unwinding the string until the flask reaches the water. Do not allow the flask to touch the walls of the well. Submerge the flask completely in the water.

Raising the Flask

Once the flask is believed to be full, rewind the string around the stick to raise the flask.

Replacing the Stopper

Before replacing the stopper, pour out a small amount of water to leave an air space, which will facilitate the shaking of the sample at the analysis stage. Then replace the stopper on the flask. Replace the protecting paper sleeve and tie it in place with the string.

a.4 Springs

For collecting water samples from springs, follow the methods described for components or for dug wells. The sampling procedure will depend on the facilities available at the sampling site.

a.5 Water Courses

Opening the Sterilized Flask

Untie the string that holds the protecting paper sleeve in place, take off the sleeve and unscrew the cap.

Taking the Sample

Holding the flask by the lower part, submerge it to a depth of 20 cm with the mouth slightly upward. If there is a current of water, the mouth of the flask should face the flow of water.

Replacing the Stopper

Before replacing the stopper, pour out a small amount of water to leave a small air space which will facilitate the shaking of the sample at the analysis stage. Then replace the stopper on the flask. Replace the protecting paper sleeve and tie it in place with the string.

Chemical

In these specific cases, the same care must be taken during the sampling as that indicated for the bacteriological analyses.

The only exception is in the rinsing of the sample bottles during the sampling process, which should be carried out two consecutive times before taking the final sample. Once the sample has been collected, and depending on the type of analysis to be performed, the appropriate preservative is added.

5. Identification

Once the sample has been taken, the flask must be labeled with the code number of the locality, the date of sampling and the number of the sample. The basic data must be recorded on form M-4 shown in Annex 4.

Care should be taken that the code number of the sample that appears on the flask is the same as is written on form M-4.

6. Preservation

It is impossible to recommend the exact time between sample collection and analysis. However, the following general points should be taken into account.

Bacteriological

In the case of samples of drinking water suspected of being slightly contaminated and without any type of preservation (refrigeration) it is acceptable for up to two hours to elapse between the sampling and the beginning of the analysis. Refrigerated samples should be analyzed no later than 24 hours after being taken.

Chemical

This group of analyses should be divided into two parts, the first comprising calcium, chlorides, total hardness, magnesium, sulfates, total residuals, fluoride, nitrate, pH and turbidity, which require only refrigeration and a maximum period of seven days between sample collection and analysis.

The second group is represented by aluminum, zinc, copper, iron, manganese, arsenic, cadmium, chromium, mercury and lead. For these analyses special preservation is called for, necessitating the addition of 5 mL of concentrated nitric acid per liter of sample, and the time between sample collection and analysis can be up to three months. Table 1 shows the types of preservatives to be used in the conservation of water samples.

Table 1. Containers and Type of Preservatives by Group of Determinations

Determination	Type of Container and Volume*	Preservative
Bacteriological	G 120 mL	Refrigeration to 4 °C
Physical		
Non Metal	P,G 500 mL	Refrigeration to 4 °C
Metal	P,G 500 mL	Nitric acid 5 mL/L
Chemical		
Non Metal	P,G 500 mL	Refrigeration to 4 °C
Metal	P,G 1,000 mL	Nitric acid 5 mL/L

* G = Glass P = Plastic

7. Packing and Transportation

The samples sent to the Regional Laboratory or Central Laboratory should be adequately packed in strong cases.

The bottles or flasks should be accommodated in the packing cases in such a way as to make it unlikely that they will knock against each other and break. In the event that they need to be refrigerated, this aspect must be taken into account, since extra space will need to be provided for the coolant mixes or the ice.

8. Reporting the Findings

Models of forms to be used by the local and central laboratories to report the analytical test findings are shown in Forms L-1 and L-2.

FORM L-1

**MINISTRY OF HEALTH
EXECUTIVE OFFICE OF ENVIRONMENTAL HEALTH - CUZCO
SANBASUR PROJECT**

**REPORT ON ANALYSIS OF WATER SAMPLES
Peripheral Laboratory**

ORIGIN **CODE** _____
 Town _____ District _____
 Province _____ Department _____

SAMPLING

Date of sampling: _____
 Date and time of entry to laboratory: _____
 Date and time of analysis: _____
 Sampled by: _____

RESULTS

Distribution Network

House	Laboratory code	Address	Time of sampling	Turbidity (NTU)	Chlorine residual (mg/L)	Coliforms UFC/100 mL	
						Total	Thermo-tolerant
1							
2							
3							
4							
5							
6							

Components

Order	Laboratory code	Type	Time of sampling	Turbidity (NTU)	Chlorine residual (mg/L)	Coliforms UFC/100 mL	
						Total	Thermo-tolerant
1							
2							
3							

Date: _____

Analyst: _____

Signature _____

FORM L-2

MINISTRY OF HEALTH
EXECUTIVE OFFICE OF ENVIRONMENTAL HEALTH - CUZCO
SANBASUR PROJECT
REPORT ON PHYSICO-CHEMICAL ANALYSIS OF WATER SAMPLE
Central Laboratory

ORIGIN _____ **CODE** _____

Sampling site _____

Town _____ District _____

Province _____ Department _____

SAMPLING

Date and time of sampling: _____

Date and time of entry to laboratory: _____

Date of beginning of analysis: _____

Sampled by: _____

RESULTS

Parameter	Expression	Concentration
Turbidity	NTU	
pH	Unit of pH	
Aluminum	mg/L as Al	
Calcium	mg/L as Ca	
Zinc	mg/L as Zn	
Chloride	mg/L as Cl	
Copper	mg/L as Cu	
Total hardness	mg/L as CaCO ₃	
Iron	mg/L as Fe	
Magnesium	mg/L as Mg	
Manganese	mg/L as Mn	
Sulfate	mg/L as SO ₄ ⁻	
Total residual	mg/L	
Arsenic	mg/L as As	
Cadmium	mg/L as Cd	
Chromium	mg/L as Cr	
Fluoride	mg/L as F	
Mercury	mg/L as Hg	
Nitrate	mg/L as NO ₃ ⁻	
Lead	mg/L as Pb	

Date: _____

Analyst: _____ Signature: _____

ANNEX 6

TRAINING PROGRAM

Program of the Training Course for Technicians in Sanitation

Time	Topic	Type of Session
8:00 - 8:30	Registration	
8:30 – 8:45	Presentation of participants and expectations	Group dynamics
8:45 – 9:15	Water and health	Presentation
9:15 – 10:00	Ideas on control and surveillance of drinking water quality	Presentation
10:00 – 10:15	Break	
10:15 – 10:45	Drinking water quality standards	Presentation
10:45 – 11:30	Characteristics of water supply services	Presentation
11:30 – 12:30	Sanitary inspection	Presentation
12:30 – 13:30	Lunch	
13:30 – 14:00	Sanitary inspection	Presentation
14:00 – 14:45	Techniques for sample collection and preservation	Presentation
14:45 – 15:30	Field analysis	Practical work
15:30 – 15:45	Break	
15:45 – 16:15	Interpretation and analysis of findings	Presentation
16:15 – 16:45	Identification of corrective measures	Workshop
16:45 – 17:30	Roundtable discussion	Roundtable discussion
17:30 – 17:45	Evaluation of the course-workshop	Evaluation
17:45 – 18:00	Closing ceremony	

ANNEX 7

INFORMATION FLOW

1. Introduction

The assessment of the water supply service includes the evaluation of water quality, the sanitary inspection, examination of service management, the community's habits of hygiene, and the prevalence of water-borne diseases, and the findings it produces must flow toward the pertinent higher levels to rate overall service quality and identify the corrective measures necessary to improve the water supply service for the benefit of the users' health.

To meet the goal of surveillance of drinking water quality it is necessary to identify the agencies involved, the responsibilities of each participant, and the routes the information must follow through the whole administrative system of the health service in the Cuzco Health Region until it arrives at the agency responsible for the surveillance of water quality.

2. Reporting the Findings

The results of the analyses of water samples performed in the communities, district laboratories and central laboratory, as well as the information relating to sanitary inspection, system management, prevalent diseases, and habits of hygiene, must be reported to the pertinent levels where they should be carefully processed to determine, for each community evaluated, the quality of the drinking water, the quality of the existing water supply service, and the principal defects identified, as well as the kind of action required to improve the quality of the service.

At first, until responsibilities are assigned to other agents involved in the follow-up and supervision of the community water supply systems, the information to be sent to the next tier up by each of the agents belonging to the decentralized health institutions is as follows:

Sanitary inspector:

Sanitary Inspection Report. (Annex 9).

Form M-1.- "Community Registration" (Annex 4).

Form M-2.- "Assessment of Management and Coverage" (Annex 4).

Form M-3.- "Assessment of the Sanitary Condition of the Water Supply Infrastructure" (Annex 4).

Form M-4.- "Water Sample Collection and Assessment of Service Quality" (Annex 4).

Form M-5.- "Verification of Habits of Hygiene and Presence of Diseases in the Community" (Annex 4).

Form M-6.- "Verification of Habits of Hygiene in the School Population" (Annex 4).

Peripheral Laboratory:

Form L-1.- "Report on Analysis of Water Samples" (Table 2 Annex 5).

Central Laboratory:

Form L-2.- "Report on Physico-Chemical Analysis of Water Sample" (Form L-2 in Annex 5).

3. Planning

Since the Health personnel have to visit each community once a month, and since this visit can require a sanitary inspection, management assessment and evaluation of habits of hygiene, as well as water analyses on site, in the local laboratory, and/or the central laboratory, it is indispensable that the agency responsible for surveillance of water quality, together with the laboratory, plan all these activities, taking special care with respect to the scheduling of physico-chemical and metals analyses in order to prevent unnecessary congestion in the central laboratory.

4. Information Flow

The findings of the evaluation of the water quality, condition of the infrastructure of the water supply system, system management, habits of hygiene, and prevalence of diseases must be reported to the community Water Board and authorities, so that remedial measures may be introduced promptly. They must also be reported to the Surveillance Agency for the latter to perform follow-up on the community's compliance with the report recommendations, to ensure an improvement in the quality of the drinking water.

The Surveillance Agency, for its part, periodically summarizes all the information relating to water quality and forwards it to the pertinent authorities. These reporting processes are carried out on an ongoing basis, fed by an efficient information system, at the regional and national level. See Figure 1 for an information and notification flow chart.

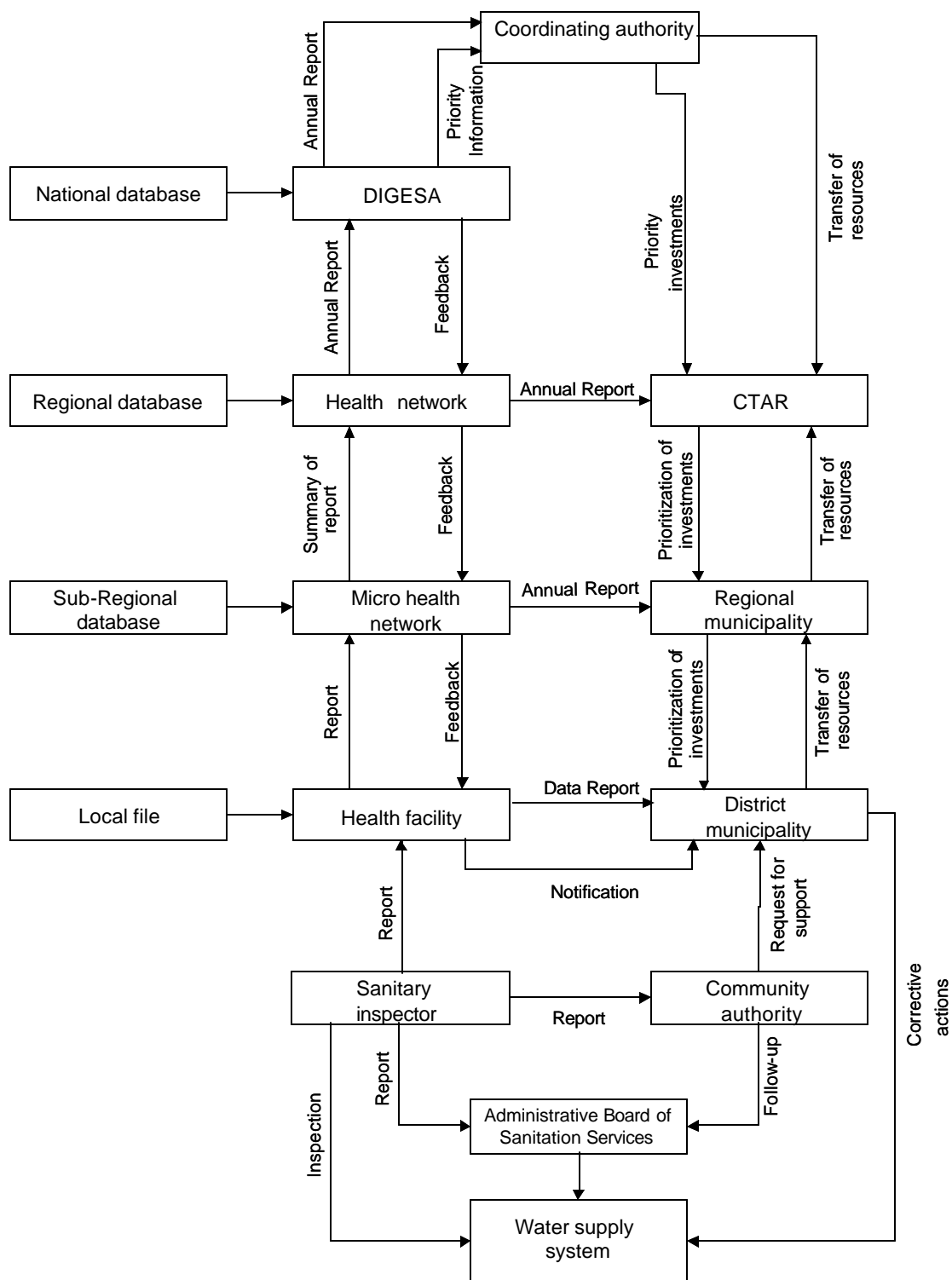

Figure 1. Information Flow Surveillance of the Quality of the Water Supply Services

5. Notification and Follow-Up

The health personnel of the Health Post or Health Center responsible for assessing the condition of administrative management, water quality, condition of the supply system, hygiene and prevalent diseases must notify the Water Board of the inspected community, as well as the community authority, of the results of their general observations, together with a list of the remedial measures necessary to improve the quality of the water and of the water supply service.

The notification to the Water Board is effected using Form N-1 the first time and Form N-2 in the event that the first notification was not heeded.

Form N-1 consists of two parts, the first listing analytical results (coliforms, turbidity and free chlorine) from each one of the points evaluated that do not meet the Health Authority standards, and the second listing any physical faults or defects of the water supply system, problems in the administrative management of the supply service, shortcomings in habits of hygiene, and the level of diseases. The purpose of this form is to urge the Water Board to schedule the actions required to correct the shortcomings or defects indicated in the report or to request any support they may need in this reference from the pertinent authorities.

Form N-2 is used when the Water Board is found to have taken no action on the first notification or when, in spite of corrective measures, the defects or shortcomings are still present.

Notifications N-1 and N-2 are made out in triplicate and distributed in the following way:

File of the health institution that made the observations	1 copy
Water Board of the evaluated community	1 copy
Executive Office of Environmental Health	1 copy

The health personnel of the Health Post or Center responsible for the evaluations of the water supply systems should submit a quarterly report to the next higher level on the actions carried out in the preceding quarter, using Forms S-1 and S-2. These forms, filled out for each community, are used to note everything related to the collection of water samples, notifications and principal defects in the water supply system, as well as observations on management, habits of hygiene and the number of diseases detected.

Form S-1 should be made out in triplicate and distributed in the following way:

File of the health institution that made the observations	1 copy
Immediately superior Health Authority	1 copy
Executive Office of Environmental Health	1 copy

FORM N-1

The Chairperson
Water Board of the Community of

Dear Sir or Madam:

Re: Surveillance of the Quality of Drinking Water

In the evaluation carried out on(date) of the water supply service in your community it was found that the quality of the water service does not comply with current sanitary regulations. To this effect, the results of the water analyses were as follows:

Sampling point	Coliforms/100 mL	Turbidity (NTU)	Free Chlorine (mg/L)
.....
.....
.....
.....

The accepted values for each of the indicated parameters are:

Coliforms/100 mL	0
Turbidity	Less than 5 NTU
Free chlorine	Greater than 0.3 mg/L

Likewise, the following defects have been detected in the water supply system. These defects will have to be corrected in order to improve the quality of the water service.

.....
.....
.....
.....

With regard to administrative management, habits of hygiene, and diseases associated with bad water handling, the following aspects have been detected:

.....
.....
.....

Trusting that the pertinent corrective measures will be taken as soon as possible, we remain,

Sincerely,

.....
Health Technician

.....
Local Director

cc: File

FORM N-2

The Chairperson
Water Board of the Community of.....

Re: Surveillance of the Quality of Drinking Water

Dear Sir or Madam:

On (date)..... we sent you a first (second) notification of the following observations resulting from our inspection of the water supply system that you administer:

.....
.....
.....
.....
.....
.....
.....
.....
.....

Since days have passed without any corrective action having been taken, we repeat our observations for the second (third) time so that the corresponding remedial measures can be adopted to safeguard the health of the users of the water supply service.

Sincerely,

.....
Health Technician

.....
Local Director

cc: File

ANNEX 8

PLACES TO BE EVALUATED

Table 1. Water Supply System. SANBASUR Project

N.º	N.º	Community	Province	District	Water Source	N.º Benef.
ACOMAYO						
1	15	REHAB.KUÑUTAMBO	Acomayo	Rondocán	groundwater	600
2	16	REHAB.RONDOCÁN	Acomayo	Rondocán	groundwater	582
3	17	SAN JUAN DE QUIHUARES	Acomayo	Rondocán	groundwater	630
4	18	REHAB. YARCACUNCA	Acomayo	Rondocán	groundwater	570
5	41	PAROCCOCHA	Acomayo	Rondocán	groundwater	180
6	42	HUAQUY PARARA	Acomayo	Rondocán	groundwater	132
CALCA						
1	22	SAYHUA-SECTOR QUEBRADA	Calca	Lamay	groundwater	312
2	32	POQUES	Calca	Lamay	groundwater	324
3	48	SAYHUA	Calca	Lamay	groundwater	155
4	49	PAMPAYPATA	Calca	Lamay	groundwater	120
5	72	HUANCCO	Calca	Lamay	groundwater	245
		Huancco sector 1	Calca	Lamay	groundwater	130
		Huancco sector 2	Calca	Lamay	groundwater	115
6	151	COCHAYOC CC CACHIN	Calca	Lares	groundwater	220
7	152	MAUCAU CC PAMPACORRAL	Calca	Lares	groundwater	190
8	153	CONCEVIDAYOC	Calca	Yanatile	groundwater	160
9	154	MUYUPAY	Calca	Yanatile	groundwater	175
10	160	URCO (REHAB.)	Calca	Calca	groundwater	300
11	162	DESAGÜE CHANCAMAYO	Calca	Calca	groundwater	290
CHUMBIVILCAS						
1	1	HUAÑACAHUA	Chumbivilcas	Quiñota	groundwater	145
2	2	MATARA ATTA PALLPA	Chumbivilcas	Quiñota	groundwater	195
3	3	ALQA VICTORIA	Chumbivilcas	Velille	groundwater	222
4	4	ANAHUICHI	Chumbivilcas	Chamaca	groundwater	252
5	5	UCHUCCARCO	Chumbivilcas	Chamaca	groundwater	504
6	6	AYACCASI	Chumbivilcas	Velille	groundwater	258
7	7	CHAMACA	Chumbivilcas	Chamaca	groundwater	895
8	11	QUIÑOTA	Chumbivilcas	Quiñota	groundwater	615
9	19	CCORCAYOC ATTA PALLPA	Chumbivilcas	Quiñota	groundwater	420
10	20	SECTOR CENTRO ATTA PALLPA	Chumbivilcas	Quiñota		255
11	21	ALLPA ORCUNA ATTA PALLPA	Chumbivilcas	Quiñota	groundwater	180
12	29	CHACARAYA	Chumbivilcas	Llusco	groundwater	390
		Chacaraya sector 1	Chumbivilcas	Llusco	groundwater	220
		Chacaraya sector 2	Chumbivilcas	Llusco	groundwater	170
13	30	CHALLA CHALLA	Chumbivilcas	Llusco	groundwater	165
14	31	TACLLAPAMPA	Chumbivilcas	Velille	groundwater	135
15	33	PAMPALLACTA	Chumbivilcas	Llusco	groundwater	150
16	43	KUTUTO	Chumbivilcas	Llusco	groundwater	320
17	44	LLUSCO	Chumbivilcas	Llusco	groundwater	995
18	45	MOSCCO	Chumbivilcas	Santo Tomás	groundwater	260
19	46	VELILLE	Chumbivilcas	Velille	groundwater	650
		Velille sector 1	Chumbivilcas	Velille	groundwater	400
		Velille sector 2	Chumbivilcas	Velille	groundwater	250

N.º	N.º	Community	Province	District	Water Source	N.º Benef.
20	47	CONDES PULPERA	Chumbivilcas	Santo Tomás	groundwater	1,050
21	53	CCACHO	Chumbivilcas	Chamaca	groundwater	240
22	54	QUELLOMARCA	Chumbivilcas	Chamaca	groundwater	220
23	79	OCRA-POROHUANI	Chumbivilcas	Llusco	groundwater	125
		Ocra sector 1	Chumbivilcas	Llusco	groundwater	60
		Porohuani sector 1	Chumbivilcas	Llusco	groundwater	65
24	80	CAPILLANIYOC	Chumbivilcas	Llusco	groundwater	170
25	86	CHIRIPA	Chumbivilcas	Capacmarca	groundwater	110
26	87	QANTUTA	Chumbivilcas	Colquemarca	groundwater	310
		Qantuta sector 1	Chumbivilcas	Colquemarca	groundwater	220
		Qantuta sector 2	Chumbivilcas	Colquemarca	groundwater	90
27	88	TOMAPARADA	Chumbivilcas	Colquemarca	groundwater	165
28	89	HUISURAY	Chumbivilcas	Colquemarca	groundwater	145
29	90	EL PORVENIR	Chumbivilcas	Velille	groundwater	315
30	91	LIMAMAYO	Chumbivilcas	Chamaca	groundwater	195
		Limamayo sector	Chumbivilcas	Chamaca	groundwater	100
		Limamayo sector	Chumbivilcas	Chamaca	groundwater	95
31	92	AMPLIACION VELILLE	Chumbivilcas	Velille	groundwater	1,750
		Velille sector 1	Chumbivilcas	Velille	groundwater	1,000
		Velille sector 2	Chumbivilcas	Velille	groundwater	750
32	96	PORCHON	Chumbivilcas	Santo Tomás	groundwater	155
33	97	CHULLUNQUIA RICRAYOC	Chumbivilcas	Santo Tomás	groundwater	180
		Chullunquia	Chumbivilcas	Santo Tomás	groundwater	90
		Ricrayoc	Chumbivilcas	Santo Tomás	groundwater	90
34	98	HUAYLLAPATA	Chumbivilcas	Santo Tomás	groundwater	385
35	99	TUNYO	Chumbivilcas	Quiñota	groundwater	180
36	103	ANQOQALA	Chumbivilcas	Velille	groundwater	275
37	116	COLLPA- ASSIAJASI	Chumbivilcas	Llusco	groundwater	330
		Collpa	Chumbivilcas	Llusco	groundwater	115
		Assiajashi	Chumbivilcas	Llusco	groundwater	215
38	117	PERCATUYO	Chumbivilcas	Llusco	groundwater	280
39	118	YANQUE	Chumbivilcas	Capacmarca	groundwater	520
40	120	CENTRO INGATA	Chumbivilcas	Chamaca	groundwater	250
41	124	PUMAPUJIO TAWAY HUANCALLO	Chumbivilcas	Capacmarca	groundwater	225
		Pumapujio sector 1	Chumbivilcas	Capacmarca	groundwater	110
		Pumapujio sector 2	Chumbivilcas	Capacmarca	groundwater	115
42	125	UCHUCARCO-FUNDICIÓN	Chumbivilcas	Chamaca	groundwater	180
43	127	COCHAPATA-CUCHINCHA-YURAAQA	Chumbivilcas	Quiñota	groundwater	145
44	130	LLOQUETA- CHALANSILLO	Chumbivilcas	Quiñota	groundwater	160
		Loqueta	Chumbivilcas	Quiñota	groundwater	100
		Chalansillo	Chumbivilcas	Quiñota	groundwater	60
45	150	AMPO	Chumbivilcas	Colquemarca	groundwater	245
		Ampo sector 1	Chumbivilcas	Colquemarca	groundwater	120
		Ampo sector 2	Chumbivilcas	Colquemarca	groundwater	125
LA CONVENCION						
1	133	CHAHUARES	La Convención	Echarate	groundwater	295
		Chahuares sector 1	La Convención	Echarate	groundwater	220
		Chahuares sector 2	La Convención	Echarate	groundwater	45
		Chahuares sector 3	La Convención	Echarate	groundwater	20

N.º	N.º	Community	Province	District	Water Source	N.º Benef.
2	134	HUAYANAY	La Convención	Santa Ana	groundwater	900
		Huayanay sector 1	La Convención	Santa Ana	groundwater	500
		Huayanay sector 2	La Convención	Santa Ana	groundwater	400
3	135	VERSALLES	La Convención	Maranura	groundwater	175
4	136	SANTUATO	La Convención	Echarate	groundwater	220
		Santuato sector 1	La Convención	Echarate	groundwater	190
		Santuato sector 2	La Convención	Echarate	groundwater	30
5	137	CHAUPIMAYO	La Convención	Echarate	groundwater	225
6	138	CHIRUMBIA	La Convención	Quellouno	groundwater	200
7	139	ARAYPALLPA	La Convención	Colcha	groundwater	385
8	141	SANTUSAIRES	La Convención	Quellouno	groundwater	180
9	143	MASAPATA	La Convención	Santa Ana	groundwater	125
10	144	LLUYCHO	La Convención	Maranura	groundwater	125
11	156	CHOQUELLOHUANCO	La Convención	Huayopata	groundwater	235
		Choquellohuanco sector 1	La Convención	Huayopata	groundwater	110
		Choquellohuanco sector 2	La Convención	Huayopata	groundwater	125
12	157	JUAN VELASCO	La Convención	Huayopata	groundwater	325
13	158	SAN LORENZO	La Convención	Ocobamba	groundwater	290
PARURO						
1	8	SAN JUAN DE TARAY	Paruro	Yaurisque	groundwater	240
2	9	HACCA	Paruro	Omachá	groundwater	510
3	10	KARUSPAMPA	Paruro	Paccarectambo	groundwater	264
4	12	CCAPI	Paruro	Ccapi	groundwater	810
5	13	COYABAMBA	Paruro	Ccapi	groundwater	1,080
6	14	PACLLA	Paruro	Omachá	groundwater	450
		Sector 1 Paclla	Paruro	Omachá	groundwater	200
		Sector 1 Paclla	Paruro	Omachá	groundwater	150
		Sector 1 Paclla	Paruro	Omachá	groundwater	100
7	39	SUTICC PUNA	Paruro	Paruro	groundwater	179
8	40	PUCA PUCA	Paruro	Paruro	groundwater	115
9	50	CHIFYA	Paruro	Huanquite	groundwater	250
10	51	TOCTOHUAYLLA	Paruro	Huanquite	groundwater	200
11	52	YAUURISQUE	Paruro	Yaurisque	groundwater	610
12	59	CHAPINA	Paruro	Omachá	groundwater	130
13	60	OSCOLLOPATA	Paruro	Omachá	groundwater	300
14	61	TAHUI	Paruro	Omachá	groundwater	195
15	62	TAUCABAMBA	Paruro	Ccapi	groundwater	91
16	63	PARCCO	Paruro	Ccapi	groundwater	189
17	74	QOSQOITE	Paruro	Ccapi	groundwater	330
18	81	PERCAJATA	Paruro	Omachá	groundwater	230
19	82	LEQUEUCO-RIO BRANCO - HATUNCACHI	Paruro	Omachá	groundwater	370
		Lequeuco sector 1	Paruro	Omachá	groundwater	300
		Lequeuco sector 2	Paruro	Omachá	groundwater	70
20	83	OMACHA	Paruro	Omachá	groundwater	375
21	93	VISTA ALEGRE	Paruro	Ccapi	groundwater	155
22	94	UCHUCO - QUEHUAYLLO	Paruro	Ccapi	groundwater	180
		Uchuco	Paruro	Ccapi	groundwater	90
		Quehuayllo	Paruro	Ccapi	groundwater	90
23	95	CHOCHO	Paruro	Ccapi	groundwater	95
24	100	PARCCO	Paruro	Accha	groundwater	385
25	101	COCHAPATA	Paruro	Yaurisque	groundwater	325

N.º	N.º	Community	Province	District	Water Source	N.º Benef.
26	102	UYLLUMPA	Paruro	Ccapi	groundwater	150
27	107	PICHACA	Paruro	Omacha	groundwater	200
28	108	ANTAYAJE	Paruro	Omacha	groundwater	355
29	114	POMATE	Paruro	Yaurisque	groundwater	325
		Pomate sector 1	Paruro	Yaurisque	groundwater	80
		Pomate sector 2	Paruro	Yaurisque	groundwater	245
30	122	COLCHA	Paruro	Colcha	groundwater	450
31	123	PAMPACUCHO	Paruro	Colcha	groundwater	250
32	129	SAYHUACALLA	Paruro	Yaurisque	groundwater	175
33	131	HAYA- HUYAYHUI	Paruro	Accha	groundwater	330
		Haya sector 1	Paruro	Accha	groundwater	80
		Haya sector 2	Paruro	Accha	groundwater	250
34	140	COCHIRUHUAY	Paruro	Colcha	groundwater	575
		Cochiruhuy sector 1	Paruro	Colcha	groundwater	200
		Cochiruhuy sector 2	Paruro	Colcha	groundwater	375
35	145	UMASHUAYLLA- ANCASCOCHA	Paruro	Omacha	groundwater	190
		Umashuaylla sector 1	Paruro	Omacha	groundwater	100
		Ancascocha sector 1	Paruro	Omacha	groundwater	90
36	159	RANRACASA	Paruro	Yaurisque	groundwater	415
37	161	DESAGÜE CCAPI	Paruro	Paruro	groundwater	720
CANCHIS						
1	71	JUCUYRE	Canchis	Combapata	groundwater	245
QUISPICANCHI						
1	28	HUARA HUARA	Quispicanchi	Ccateca	groundwater	85
2	75	PACCHANTA SECTOR 1	Quispicanchi	Ocongate	groundwater	220
		Pacchanta sector 1	Quispicanchi	Ocongate	groundwater	160
		Pacchanta sector 2	Quispicanchi	Ocongate	groundwater	60
3	76	PAMPACANCHA	Quispicanchi	Ocongate	groundwater	285
		Pampacancha sector 1	Quispicanchi	Ocongate	groundwater	200
		Pampacancha sector 2	Quispicanchi	Ocongate	groundwater	85
4	77	TAYANCANI	Quispicanchi	Carhuayo	groundwater	230
		Tayancani sector 1	Quispicanchi	Carhuayo	groundwater	100
		Tayancani sector 2	Quispicanchi	Carhuayo	groundwater	100
		Tayancani Others	Quispicanchi	Carhuayo	groundwater	30
5	78	CONCHOPATA CORICOCHA	Quispicanchi	Quiquijana	groundwater	325
		Conchopata sector 1	Quispicanchi	Quiquijana	groundwater	195
		Conchopata sector 2	Quispicanchi	Quiquijana	groundwater	130
6	84	PAMPAQUEHUAR	Quispicanchi	Urcos	groundwater	880
7	85	PATAQUEHUAR	Quispicanchi	Urcos	groundwater	275
8	104	WACWA LAGUNA	Quispicanchi	Quiquijana	groundwater	410
		Wacwa sector 1	Quispicanchi	Quiquijana	groundwater	245
		Wacwa sector 2	Quispicanchi	Quiquijana	groundwater	165
9	105	MARCANI QOÑAMURO	Quispicanchi	Urcos	groundwater	300
10	106	HUAYLLABAMBA	Quispicanchi	Ccatca	groundwater	175
11	109	ALTO SERRANUYOC	Quispicanchi	Ccatca	groundwater	175
12	110	ANTALLACTA	Quispicanchi	Quiquijana	groundwater	450
13	111	CAURI	Quispicanchi	Ccatca	groundwater	1,030
14	112	CHECACHIMPA	Quispicanchi	Ocongate	groundwater	585
15	113	QENPORAY	Quispicanchi	Quiquijana	groundwater	125

N.º	N.º	Community	Province	District	Water Source	N.º Benef.
16	115	HUASACMAYO	Quispicanchi	Quiquijana	groundwater	650
17	119	HUACARPINAYANAMA	Quispicanchi	Ocongate	groundwater	230
18	121	CHURUBAMBA	Quispicanchi	Andahuaylillas	groundwater	300
19	126	KUCHIRUMI	Quispicanchi	Quiquijana	groundwater	250
		Kuchirumi sector 1	Quispicanchi	Quiquijana	groundwater	150
		Kuchirumi sector 2	Quispicanchi	Quiquijana	groundwater	100
20	128	CHUCLLUHUIRE	Quispicanchi	Carhuayo	groundwater	170
		Chuclluhuire sector 1	Quispicanchi	Carhuayo	groundwater	100
		Chuclluhuire sector 2	Quispicanchi	Carhuayo	groundwater	70
21	132	YURACMAYO	Quispicanchi	Ccatca	groundwater	350
22	142	DESAGUE ATAPATA	Quispicanchi	Ccatca	groundwater	250
23	147	PACCHA Y SAÑO	Quispicanchi	Cusipata	groundwater	280
		Paccha y Saño	Quispicanchi	Cusipata	groundwater	140
		Saño	Quispicanchi	Cusipata	groundwater	140
24	148	ACOCUNCA	Quispicanchi	Ocongate	groundwater	365
25	149	PHINAY PHUYUCUNCA	Quispicanchi	Huaro	groundwater	315
		Phiñay sector 1	Quispicanchi	Huaro	groundwater	200
		Phiñay sector 2	Quispicanchi	Huaro	groundwater	115
26	155	SULLUMAYO	Quispicanchi	Huaro	groundwater	265
		Sullumayo sector 1	Quispicanchi	Huaro	groundwater	200
		Sullumayo sector 2	Quispicanchi	Huaro	groundwater	65
27	23	QOÑAMURO	Quispicanchi	Ocongate	groundwater	290
28	24	SUMANA	Quispicanchi	Ccarhuayo	groundwater	200
29	25	IPACUNA	Quispicanchi	Urcos	groundwater	200
30	26	CULLY	Quispicanchi	Urcos	groundwater	180
31	27	CCOPI	Quispicanchi	Ccateca	groundwater	480
32	34	PALLPACALLA	Quispicanchi	Huaro	groundwater	180
33	35	PUCA PUCA	Quispicanchi	Andahuaylillas	groundwater	115
34	36	MANCCO	Quispicanchi	Andahuaylillas	groundwater	195
35	37	PAMPACHULLA	Quispicanchi	Urcos	groundwater	1,050
		Pampachulla sector 1	Quispicanchi	Urcos	groundwater	800
		Pampachulla sector 2	Quispicanchi	Urcos	groundwater	250
36	38	PUCA RUMI	Quispicanchi	Ocongate	groundwater	475
37	55	LAURAMARCA	Quispicanchi	Ocongate	groundwater	350
		Lauramarca sector 1	Quispicanchi	Ocongate	groundwater	50
		Lauramarca sector 2	Quispicanchi	Ocongate	groundwater	300
38	56	HUACATINCO	Quispicanchi	Ocongate	groundwater	645
		Huacatinco sector 1	Quispicanchi	Ocongate	groundwater	300
		Huacatinco sector 2	Quispicanchi	Ocongate	groundwater	140
		Huacatinco sector 3	Quispicanchi	Ocongate	groundwater	100
		Huacatinco sector 4	Quispicanchi	Ocongate	groundwater	105
39	57	MOLLEBAMBA	Quispicanchi	Urcos	groundwater	900
40	58	UMUTU	Quispicanchi	Urcos	groundwater	700
		Umuto sector 1	Quispicanchi	Urcos	groundwater	420
		Umuto sector 2	Quispicanchi	Urcos	groundwater	380
41	64	PARCOCALLA	Quispicanchi	Carhuayo	groundwater	525
42	65	QUEROCHIMPA	Quispicanchi	Carhuayo	groundwater	525
43	66	URPAY	Quispicanchi	Huaro	groundwater	775
44	67	ARAHUARA	Quispicanchi	Huaro	groundwater	125
45	68	ATAPATA	Quispicanchi	Catca	groundwater	350
46	69	PUMAORCCO	Quispicanchi	Catca	groundwater	220
47	70	COLLPAMAYO-UMUTO	Quispicanchi	Urcos	groundwater	300
48	73	AQOCANCHA/LLAULLIWAYOC	Quispicanchi	Quiquijana	groundwater	275

ANNEX 9

DETERMINATION OF NUMBER OF SAMPLES

1. Scope

The proposal of the Surveillance Program is to carry out surveillance of water quality of the water supply services constructed by the SANBASUR Project, numbering 157 administrations and 203 water supply systems in the year 2000. The construction of 90 additional systems is planned for the years 2001-2003, giving a total of 293 water supply systems by the year 2003, spread over the seven provinces of the department of Cuzco.

The water supply systems in the rural communities consist of different operations or unit components such as: intake, conduction line, storage, feeder main, pressure-relief chambers, distribution network, and finally, home connections. With respect to procuring information to assess service quality, the following factors are taken into consideration: drinking water quality, the amount consumed, continuity of the service, the coverage of the distribution network, and the cost of the water supply service.

With regard to the responsibilities and activities of the central and local laboratories of DESA-Cuzco working on the evaluation of water quality in compliance with the Program for the Surveillance of Drinking Water, they include the following:

- a) Evaluation and implementation of the central laboratory and the local laboratories.
- b) Establishment of the sampling system and execution of the sampling program to evaluate the quality of the water supplied.
- c) Execution of the Sampling Program and analysis of the water samples.

2. Work Plan

Figure 1 shows the work plan to be applied for the evaluation of drinking water quality.

3. Number and Frequency of Samples

To ensure that a water supply system is meeting quality standards, it is important that water samples be tested regularly in order to detect and clear up any doubts about the presence of organisms indicating contamination or about the physical-chemical quality. In any case the frequency of sampling both of the components of the supply system and of the distribution system is directly proportional to the density of the population served. In Annex 3 the sampling frequencies are indicated, as well as the number of samples to be taken by each group respectively.

The total number of analyses required to be carried out in the three years planned for control and surveillance of drinking water quality for the rural populations of the Cuzco Health Region is summarized in the following table.

Table 1. Analyses Required in Three Years Planned for Control and Surveillance of Drinking Water Quality

CHARACTERISTICS	YEAR			
	2000/base	2001	2002	2003
SYSTEMS (totals)	203	233	263	293
SYSTEMS (to evaluate)		85	263	293
DETERMINATIONS				
Coliforms	3,066	1,284	3,973	4,426
Turbidity/pH	6,132	2,568	7,945	8,851
Chlorine residual	6,132	2,568	7,945	8,851
Physical-chemical	201	85	261	291
Metals	101	43	131	146

4. Timeframe for Surveillance of Water Systems (203 Systems Constructed by DIGESA-COSUDE)

Table 2. Chronogram of Activities

ACTIVITIES	2001				2002				2003			
	1	2	3	4	1	2	3	4	1	2	3	4
Checking of books and statistics, gathering of the information needed for drawing up the Program.	x											
Acomayo (6 systems)			x	x	x	x	x	x	x	x	x	x
Calca (11 systems)			x	x	x	x	x	x	x	x	x	x
Canchis (1 system)			x	x	x	x	x	x	x	x	x	x
Chumbivilcas (44 systems)			x	x	x	x	x	x	x	x	x	x
La Convención (18 systems)			x	x	x	x	x	x	x	x	x	x
Paruro (45 systems)			x	x	x	x	x	x	x	x	x	x
Quispicanchi (65 systems)			x	x	x	x	x	x	x	x	x	x
Drawing up the baseline			x	x	x	x	x	x	x	x	x	x
Preliminary reports				x			x					x
Final Report												x

5. Budget

In determining the cost per year of performing the analyses, the following values have been considered:

Coliforms	S/.	3.63
Turbidity/pH *	S/.	0.25

Chlorine residual *	S/.	0.25
Physical-chemical	S/.	8.77
Metals **	S/.	10.00

* Cost of equipment not included

** Cost of transportation to Lima for analysis by DIGESA

The cost of carrying out the analyses for the surveillance and for determining the base line of new interventions in the year 2001 amounts to seven thousand eight hundred Nuevos Soles (S/. 7,800.00), of which seven thousand one hundred twenty Nuevos Soles (S/. 7,120.00) corresponds to surveillance and six hundred eighty Nuevos Soles (S/. 680.00) to the baseline. For 2002 and 2003, investment could be in the region of S/. 22,000.00 and S/. 24,500.00 respectively. These costs are only for the consumption of chemicals and culture media and do not include replacement of glassware, purchase or repair of equipment or instruments, nor the labor for performing the analyses and collecting samples.

Table 3. Cost of Analyses
(in Nuevos Soles)

Surveillance				
Year	2001/base	2001	2002	2003
Systems (total)	203	233	263	293
Systems (to be assessed)		85	263	293
Determinations				
Coliforms	11.129,58	4.660,92	14.421,99	16.066,38
Turbidity/pH	1.533,00	642,00	1.986,25	2.212,75
Chlorine residual	1.533,00	642,00	1.986,25	2.212,75
Physico-chemical	1.762,77	745,45	2.288,97	2.552,07
Metals	1.010,00	430,00	1.310,00	1.460,00
Sub-total	16.968,35	7.120,37	21.993,46	24.503,95
Base Line				
Year		2001	2002	2003
Systems		30	30	30
Determinations				
Coliforms		108,90	108,90	108,90
Turbidity/pH		7,50	7,50	7,50
Physico-chemical		263,10	263,10	263,10
Metals		300,00	300,00	300,00
Sub-total		679,50	679,50	679,50
Total	16.968,35	7.799,87	22.672,96	25.183,45

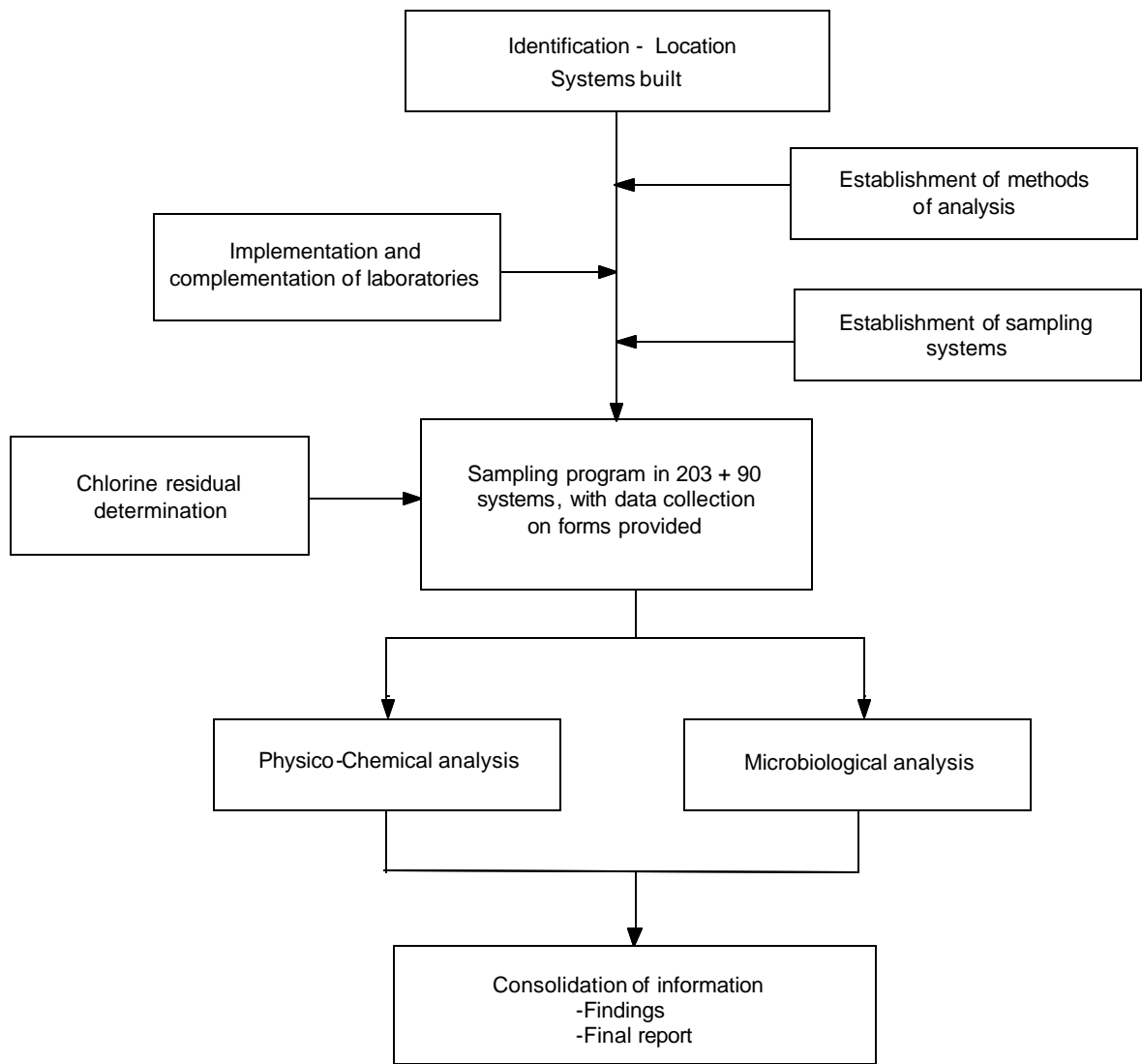

Figure 1. Program for the Surveillance of Drinking Water Quality, SANBASUR Project

**Table 4. Sampling Plan for the Surveillance of the Water Quality,
and Water Supply Administrations and Systems
SANBASUR PROJECT - (2001)**

Province	Administrations	Water Supply Systems		
		Surface	Ground	Total
Acomayo	6	0	6	6
Anta	-	-	-	-
Calca	11	0	12	12
Canas	-	-	-	-
Canchis	1	0	1	1
Cuzco	-	-	-	-
Chumbivilcas	45	0	56	56
Espinar	-	-	-	-
La Convención	13	2	16	18
Paruro	37	0	45	45
Paucartambo	-	-	-	-
Quispicanchi	48	0	65	65
Urubamba	-	-	-	-
TOTAL	161	2	201	203

**Table 5. Summary of the Water Supply Systems
SANBASUR Project Ground and Surface Water**

	Province	Total	Size of Population		
			<200	201 - 800	801 - 2000
Groundwater	Acomayo	6	2	4	0
	Anta	--	--	--	--
	Calca	12	7	5	0
	Canas	--	--	--	--
	Canchis	1	0	1	0
	Cuzco	--	--	--	--
	Chumbivilcas	56	29	23	4
	Espinar	--	--	--	--
	La Convención	16	11	5	0
	Paruro	45	23	20	2
	Paucartambo	--	--	--	--
	Quispicanchi	65	35	27	3
	Urubamba	--	--	--	--
	Acomayo	0	0	0	0
Surface	Anta	--	--	--	--
	Calca	0	0	0	0
	Canas	--	--	--	--
	Canchis	0	0	0	0
	Cuzco	--	--	--	--
	Chumbivilcas	0	0	0	0
	La Convención	2	0	2	0
	Paruro	0	0	0	0
	Paucartambo	--	--	--	--
	Quispicanchi	0	0	0	0
	Urubamba	--	--	--	--
	Subtotal	203	107	87	9
	Espinar	--	--	--	--
	Total	203	107	87	9

Table 6. Number of Samples for Physico-Chemical Analysis Groundwater 2001

Province	Systems (N.º)	Size	Treatment plant, sources of groundwater and service reservoirs				Distribution network	
			Coliforms	Turbidity and pH	Physico-chemical	Metals	Coliforms	Turbidity and pH
Acomayo	2	<200	12	24	2	1.0	12	24
	4	201 – 800	24	48	4	2.0	48	96
	0	801 – 2,000	0	0	0	0	0	0
Calca	7	<200	42	84	7	3.5	42	84
	5	201 – 800	30	60	5	2.5	60	120
	0	801 – 2,000	0	0	0	0.0	0	0
Canchis	0	<200	0	0	0	0.0	0	0
	1	201 – 800	6	12	1	0.5	12	24
	0	801 – 2,000	0	0	0	0.0	0	0
Chumbivilcas	29	<200	174	348	29	14.5	174	348
	23	201 – 800	138	276	23	11.5	276	552
	4	801 – 2,000	24	48	4	2.0	72	144
La Convención	11	<200	66	132	11	5.5	66	132
	5	201 – 800	30	60	5	2.5	60	120
	0	801 – 2,000	0	0	0	0.0	0	0
Paruro	23	<200	138	276	23	11.5	138	276
	20	201 – 800	120	240	20	10.0	240	480
	2	801 – 2,000	12	24	2	1.0	36	72
Quispicanchi	35	<200	210	420	35	17.5	210	420
	27	201 – 800	162	324	27	13.5	324	648
	3	801 – 2,000	18	36	3	1.5	54	108
Subtotal	201		1,206	2,412	201	100.5	1,824	3,648

Table 7. Number of Samples for Physico-Chemical Analysis Surface Water - 2001

Province	Systems (N.º)	Size	Treatment plant, sources of surface water and service reservoirs				Distribution network	
			Coliforms	Turbidity and pH	Physico-Chemical	Metals	Coliforms	Turbidity and pH
La Convención	0	<200	0	0	0	0.0	0	0
	2	201 – 800	12	24	4	2.0	24	48
	0	801 – 2000	0	0	0	0.0	0	0
Subtotal	2		12	24	4	2.0	24	48
Total	203		1,218	2,436	205	102.5	1,848	3,696

**Table 8. Number of Samples for Chlorine Residual Analysis
Groundwater - 2001**

Province	Systems (N.º)	Size	Treatment plant, sources of groundwater and service reservoirs	Distribution network
Acomayo	2	<200	24	24
	4	201 – 800	48	96
	0	801 – 2,000	0	0
Calca	7	<200	84	84
	5	201 – 800	60	120
	0	801 – 2,000	0	0
Canchis	0	<200	0	0
	1	201 – 800	12	24
	0	801 – 2,000	0	0
Chumbivilcas	29	<200	348	348
	23	201 – 800	276	552
	4	801 – 2,000	48	144
La Convención	11	<200	132	132
	5	201 – 800	60	120
	0	801 – 2,000	0	0
Paruro	23	<200	276	276
	20	201 – 800	240	480
	2	801 – 2,000	24	72
Quispicanchi	35	<200	420	420
	27	201 – 800	324	648
	3	801 – 2,000	36	108
Subtotal	201		2,412	3,648

**Table 9. Number of Samples for Chlorine Residual Analysis
Surface Water – 2001**

Province	Systems (N.º)	Size	Treatment plant, sources of surface water and service reservoirs	Distribution network
La Convención	0	<200	0	0
	2	201 – 800	24	48
	0	801 – 2,000	0	0
Sub-total	2		24	48
Total	203		2,436	3,696

Table 10. Projections

Year	2001/base	2001	2002	2003
Administrations	161	187	217	247
Systems	203	233	263	293
Determinations				
Coliforms	3,066	3,520	3,973	4,426
Turbidity/pH	6,132	7,039	7,945	8,851
Chlorine residual	6,132	7,039	7,945	8,851
Physico-chemical	201	231	261	291
Metals	101	116	131	146

ANNEX 10

SANITARY INSPECTION REPORT FORM

SANITARY INSPECTION OF THE SYSTEM

In the Sector/Annex (Community) ofof the locality of, district of province of and department of, on this day (date).....of (month).....of 20..... the sanitary inspection of the system was carried out with the participation, on behalf of the Water Board, of the following:.....and on behalf of the Ministry of Health, Mr/Ms.....

As a result of the inspection of each of the parts of the system and of the water samples, a deterioration was detected in the quality of the water consumed by the population, which is placing their health at serious risk; for this reason, improvements will have to be made in the water supply system, to improve the conditions of the supply of drinking water. The main defects identified are noted below:

Intakes and Water Reunion Boxes	
There is no protecting fence to prevent the access of people or animals to the installation or its vicinity	
There is no surface water diversion ditch, or it is not in good condition	
There is no sanitary lid, or it has no lock	
The structure is not in good condition (cracked or leaking)	
The inside of the structure is dirty	
There are puddles of water or fecal matter in the vicinity of the intake structure	
Deep Well	
There is no well housing or it is not protected against the entry of people or animals	
The pump is not mounted on a concrete slab, or the slab is cracked	
The mouth of the well is at the same level as the concrete slab	
There are puddles of water or fecal matter in the vicinity of the well	
Filtration Gallery and Water Reunion Boxes	
There is no protecting fence and people or animals have access to the installation or its vicinity	
There is no sanitary lid, or it has no lock	
The structure is not in good condition (cracked or leaking)	
The inside of the gallery is dirty	
There are puddles of water or fecal matter in the vicinity of the gallery	
Intake of Surface Water without Treatment	
There is no protecting fence and people or animals have access to the intake structure or its vicinity	
Conditions are such that surface water can enter the treatment ponds	
The intake is not in good condition (cracked or leaking)	
The inside of the intake structure is dirty	
There are puddles of water or fecal matter in the vicinity of the intake structure	
Conduction Line/Pumpline	
The line has leaks or ruptures	
Stretches of the line are above ground	
The above-ground crossings are not well protected or are not in good condition	
Air-vents and Pressure-relief Boxes in the Conduction Line	
There is no sanitary lid, or it has no lock	
The structure is not in good condition (cracked or leaking)	
There are puddles of water or fecal matter in the vicinity of the structures	
Reservoir	
There is no protective fence and people or animals have free access to the reservoir	

There is no sanitary lid, or it has no lock	
The reservoir is not in good condition (cracked or leaking)	
The inside of the reservoir is dirty	
There are puddles of water or fecal matter in the vicinity of the structure	
Feeder Main	
The pipe is leaking or broken	
Stretches of the pipe are exposed	
Pressure-Relief Boxes	
There is no sanitary lid, or it has no lock	
The structure is not in good condition (cracked or leaking)	
There are puddles of water or fecal matter in the vicinity of the structure	
Distribution Network	
The pipe is leaking or broken	
Stretches of the pipe are above the ground	
The valves do not have boxes or lids and water has collected in puddles	
Public Standpipes	
The structure of the faucet is not in good condition (cracked or leaking)	
The faucets are very dirty	
The fittings and/or tap of the faucet are not complete or are not in a good condition	
There are puddles of water or fecal matter in the vicinity of the public standpipe	
Chlorination	
There is no chlorination equipment	
The equipment is not in good condition	
The equipment is not used	
There is no stock of chlorine	
Use of Water	
A great deal of water is used watering the streets	
A great deal of water is used watering the vegetable gardens	
Home Connections	
The faucets in the homes are in bad condition	
Water has collected in the connection boxes	

.....
 Signature
 Inspector

.....
 Signature
 Administrator

.....
 Signature
 Operator

ANNEX 11
QUALITY ASSURANCE OF DATA

1. Introduction

The different activities conducted by the surveillance and control staff should be assessed to ensure the quality of the data collected throughout the evaluation process. Form E-1 is applied for this purpose. It was designed to assess staff performance in five stages:

- Number of evaluations conducted.
- Consistency of results.
- Number of direct supervisions.
- Number of field verifications.
- Quality of field work.

2. Number of Evaluations Conducted (1)

On Form E-1, opposite the name of the person responsible for the surveillance or control, indicate how many of each type of form have been completed by him/her during the month.

3. Consistency of Results (2)

The Supervisor should carefully check answers to questions in each of the different types of forms that have been completed and submitted by the field surveillance and control staff.

This revision is to determine whether the person responsible for field work has answered all of the questions in the forms relating to the installation being evaluated, and whether, in the supervisor's opinion, the answers are reliable and coherent with reality.

Acceptance or rejection of a form is decided taking into account, in the first place, the number of obligatory answers and, secondly, the reliability of the answers.

If the obligatory questions in each of the forms have not been completely answered, the form is returned so that the person responsible can complete the missing data.

With regard to reliability of the results, the number of apparently mistaken answers in the form will be counted, and the form will then be accepted or rejected according to the following criteria:

Number of questions per form reviewed	Number of questions with doubtful or mistaken answers	
	<i>Accept</i>	<i>Reject</i>
6 – 8	0	1
9 – 12	1	2
13 – 20	2	3
21 – 30	3	4
31 – 42	4	5
43 – 65	5	6

If in each batch of forms it is found that the number of evaluations or forms completed is equal to or lower than the “accept” number, the information as a whole is accepted. Otherwise, the whole batch is returned to the person in charge of the field work, for revision.

In line 2 of Form E-1, it should be noted whether the forms were accepted (A) or rejected (R).

4. Number of Direct Supervisions (3)

This section refers to the number of times the supervisor helped or supervised the personnel responsible for completing the forms. This activity is known as direct supervision or field training. The number of forms which the supervisor helped to complete or supervised is recorded in the appropriate space, for each type of form.

5. Number of Verifications Conducted in the Field (4)

The supervisor is obliged to verify independently the work of the staff responsible for gathering data in the field. To this effect, he selects ten percent of a given type of form, at random, to compare the data recorded with the real situation and thus evaluate the quality of the work performed by the staff member responsible.

The supervisor will record – for each type of form – the number of forms selected and verified in the field.

6. Quality of Field Work (5)

This value is determined for forms selected and verified in the field by the supervisor (step 4).

The supervisor records in line 5 the percentage of errors made by the person responsible for gathering data in the field, referring only to the number of questions answered.

The information is rejected if the percentage of mistaken answers is higher than ten percent (10%).

Example:

The supervisor evaluated three forms of the M2 type, in which 60 questions were answered in each form, and four, six and five errors were found, respectively. The error is determined as follows:

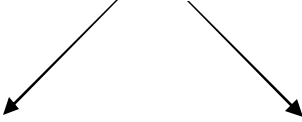
$$\frac{4 + 6 + 5}{3 \times 60} \times 100 = 8.3\%$$

Number of Forms Questions per Form

QUALITY ASSURANCE OF DATA

Date of report _____ Supervisor _____

Indicate number of evaluations per type of form conducted by each person

Name of person evaluated	Evaluation ⁽¹⁾	FORM					
		M-1	M-2	M-3	M-4	M-5	M-6
	1						
	2						
	3						
	4						
	5						
	1						
	2						
	3						
	4						
	5						
	1						
	2						
	3						
	4						
	5						

1. Number of forms completed within the month, per type
2. Consistency of results (A = Accepted; R = Rejected)
3. Direct supervision (number of forms supervised)
4. Verification in the field (number of forms verified)
5. Quality of work (percentage)

- Form M-1 Community Registration.
- Form M-2 Assessment of Management and Coverage.
- Form M-3 Assessment of Sanitary Condition of the Water Supply Infrastructure.
- Form M-4 Water Sample Collection and Assessment of Service Quality.
- Form M-5 Verification of Habits of Hygiene and Presence of Diseases in the Community.
- Form M-6 Verification of Habits of Hygiene in the School Population.