

**PRACTICAL GUIDELINES FOR  
INFECTION CONTROL  
IN  
HEALTH CARE FACILITIES**



**World Health Organization  
8 December 2003**



# CONTENTS

Foreword.....	v
1. Introduction.....	1
Background.....	1
Infection control practices .....	1
Purpose .....	1
Objectives .....	1
Use of the guidelines .....	2
2. Infection control programme .....	3
Need for an infection control programme .....	3
What is an infection control programme? .....	3
Organization of an infection control programme .....	4
Infection control committee.....	4
Infection control team.....	5
Infection control manual.....	6
Education and training of health care staff.....	6
3. Infection control practices .....	7
Standard precautions.....	7
Hand washing and Antisepsis (hand hygiene).....	7
Use of personal protective equipment .....	8
Principles for use of personal protective equipment.....	9
Prevention of needle stick/sharps injuries .....	11
Management of health-care waste .....	11
Additional (transmission-based) precautions .....	11
Airborne precautions .....	11
Droplet precautions.....	12
Contact precautions .....	12
Patient placement and transportation of patients.....	13
Patient placement.....	13
Spacing between beds.....	13
Single rooms .....	13
Anterooms.....	13

Cohorting .....	13
Transportation of patients .....	13
4. Environmental management practices .....	14
Premises/buildings .....	14
Air .....	14
Ventilation.....	14
Special air handling for airborne precautions .....	15
Protective environment .....	15
Water .....	16
Safe drinking water .....	16
Cleaning of the hospital environment .....	16
Waste management .....	16
Principles of waste management.....	17
Treatment of hazardous and clinical /infectious waste .....	17
Methods of disposal .....	17
Laundry .....	20
General instructions .....	20
Bedding .....	20
Reprocessing of instruments and equipment <sup>3</sup> .....	20
Cleaning, disinfection and sterilization.....	23
Cleaning .....	23
Disinfection.....	24
Selection of disinfectant.....	25
Sterilization .....	26
Special consideration - CJD .....	28
Used personal protective equipment .....	30
Soiled linen .....	31
Soiled patient care equipment (needles, syringes, surgical instruments and other equipment) used for patient.....	31
Equipment in the isolation unit (tables, beds, lockers, trolleys, etc).....	32
Environmental surfaces in the patient's room .....	32
5. Care of health care workers <sup>2</sup> .....	33
Exposure to human immunodeficiency virus (HIV).....	33
Exposure to hepatitis B virus .....	33
Exposure to hepatitis C virus .....	34

---

Sharps injuries .....	34
Tuberculosis.....	34
Meningococcal meningitis.....	34
SARS .....	35
Other infections; varicella, influenza, pertussis, diphtheria, rabies.....	35
6. Infection control precautions for selected situations .....	36
Severe acute respiratory syndrome (SARS) .....	36
Causative agent.....	36
Mode of transmission .....	36
Susceptibility .....	36
Clinical picture in SARS patients .....	36
Clinical case definition of SARS <sup>y</sup> .....	37
Laboratory case definition of SARS <sup>y</sup> .....	37
PCR positive for SARS-CoV.....	37
Seroconversion by ELISA or IFA .....	37
Virus isolation.....	38
Infection control precautions for SARS .....	38
Transportation of patients with SARS.....	38
Personal protective equipment used for SARS.....	39
Who should use personal protective equipment? .....	39
Waste disposal .....	39
Specimen collection and transportation.....	39
Hospital screening, admission procedures and triage.....	40
Care of SARS patients in isolation .....	40
Preparation of the isolation room .....	40
Entering the room .....	41
Attending the patient.....	41
Catering.....	41
Excreta .....	41
Dressings.....	42
Leaving the room.....	42
Discharging the patient .....	42
Care of the deceased <sup>z</sup> .....	42

Post mortem .....	43
Minimizing the risk from an infected cadaver .....	43
Use of a circulator (assistant) <sup>b</sup> .....	43
Mortuary care/ funeral director's premises <sup>c</sup> .....	43
Infections with multidrug resistant organisms .....	44
Appropriate antimicrobial use .....	44
Antimicrobial use committee .....	44
Control of endemic antibiotic resistance .....	45
Methicillin-resistant <i>Staphylococcus aureus</i> (MRSA) .....	45
Vancomycin-resistant enterococcus (VRE) .....	45
Transmission .....	46
Susceptibility .....	46
Infection control measures for VRE .....	46
Contact precautions .....	46
Multidrug-resistant tuberculosis (MDR-TB) .....	46
Susceptibility .....	46
Occurrence .....	47
Transmission .....	47
Infection control measures for MDR-TB .....	47
Standard and airborne precautions .....	47
Health care workers .....	47
Infections with viral Haemorrhagic fevers .....	47
References .....	49
Glossary .....	51
Annex 1 - Hand washing .....	53
Annex 2 - Personal protective equipment .....	58
Annex 3 - Infection Control: a quick reference guide for .....	67
Annex 4. - Suggested checklist for SARS trolley/table .....	68
Annex 5. - Isolation room .....	69
Annex 6 - Infection control advice to contacts of suspect or probable SARS cases .....	70
Annex 7 - Infection control checklist .....	72
Acknowledgements .....	74

# FOREWORD

The World Health Organization (WHO) has recognized severe acute respiratory syndrome (SARS) as the first severe and readily transmissible new disease to emerge in the 21st century. Despite rapid progress towards understanding the disease and the transmission of the SARS Co-V, there are still many gaps in our understanding of SARS. It was very clear during the SARS outbreak however, that this virus was easily spread through international air travel and close hospital contact. In fact health care facilities amplified the disease in all severely affected countries.

The experience in affected areas showed very clearly that the transmission of the SARS Co-V can generally be prevented. Because there is no known effective treatment and no available vaccine, health authorities had to resort to basic public health measures. Rapid case detection, immediate isolation, contact tracing and good infection control precautions are critical in the prevention of infection. However, as SARS spread, it became obvious that many countries lacked the necessary infrastructure, facilities, equipment and trained personnel to provide appropriate precautions. Health care facilities in both developed and developing countries were far from prepared to deal with such a disease. It is essential that all countries strengthen their regional and national surveillance and response systems and their infection control capacities, in particular hospital-based infection control departments.

In order to support countries to deal with SARS and to prevent further spread of infection, the WHO Regional Offices for South-East Asia and the Western Pacific have jointly prepared these guidelines. The guidelines address all aspects of an infection control programme and devote considerable attention to SARS. Since information on SARS is still evolving, these are interim guidelines. They may need to be updated as and when more specific information becomes available. WHO would greatly appreciate feedback from those who use these guidelines.

We hope that these guidelines will be found useful by health professionals at all levels who have to deal with SARS and other health-care-associated infections.

Dr Uton Muchtar Rafei  
Regional Director  
WHO Regional Office for South-East Asia

Dr Shigeru Omi  
Regional Director  
WHO Regional Office for Western Pacific



# 1. INTRODUCTION

## BACKGROUND

The emergence of life-threatening infections such as severe acute respiratory syndrome (SARS) and re-emerging infectious diseases like plague and tuberculosis have highlighted the need for efficient infection control programmes in all health care settings and capacity building for health care workers so they can implement them. An infection control programme puts together various practices which when used appropriately restrict the spread of infection.

A breach in infection control practices facilitates transmission of infection from patients to health care workers, other patients and attendants. It is therefore important for all health care workers, patients, their family members, friends and close contacts to adhere to the infection control guidelines strictly. It is also imperative for health care administrators to ensure implementation of the infection control programme in health care facilities.

### Infection control practices

"Standard precautions" require that health care workers assume that the blood and body substances of **all** patients are potential sources of infection, regardless of the diagnosis, or presumed infectious status. Additional precautions are needed for diseases transmitted by air, droplets and contact. These are termed "additional (transmission-based) precautions".<sup>1</sup>

The terms "standard precautions" and "additional (transmission-based) precautions" have replaced previous terms such as universal blood and body fluid precautions, universal precautions and barrier nursing. While particular care needs to be taken in the management of patients/clients known to have active infections **it must be remembered that infection will not always be detected** and complete safety can lie only in following the appropriate level of precautions.

### Purpose

The South-East Asia and Western Pacific Regional Offices of the World Health Organization (WHO) have jointly developed these guidelines to provide comprehensive information to health care workers in the prevention and control of transmissible infections. These are built on current infection control guidelines, which have recently been developed by WHO.<sup>2</sup> They place special emphasis on standard and additional (transmission-based) precautions.

The guidelines have been prepared specifically to assist infection control practitioners in the management and prevention of hospital-associated infections and to ensure that health care administrators understand the significance of infection control programmes.

### Objectives

The general objective of these guidelines is to provide administrators and health care workers with the tools to enable them to implement the infection control programme effectively in order to protect themselves and others from the transmission of infections.

The specific objectives of these guidelines are to provide directions and information in relation to:

- Facilities, equipment, and procedures necessary to implement **standard and additional (transmission-based) precautions** for control of infections
- Cleaning, disinfecting and reprocessing of reusable equipment
- Waste management
- Protection of health care workers from transmissible infections
- Infection control practices in special settings

### **Use of the guidelines**

The guidelines are generic in nature and can be used in any health care facility. Countries need to adapt them to suit their needs and context. Health care providers from Member States should periodically refer to WHO websites for up-to-date information on infectious diseases and their control.

WHO Headquarters: <http://www.who.int/>

South-East Asia Regional Office: <http://www.whosea.org>

Western Pacific Regional Office: <http://wpro.who.int>

---

## 2. INFECTION CONTROL PROGRAMME

### NEED FOR AN INFECTION CONTROL PROGRAMME

The responsible health authority should develop a national (or regional) programme to support hospitals in reducing the risk of health-care-associated or nosocomial infections. More information on infection control programmes can be found in the document "Prevention of hospital-acquired infections" at:

<http://www.who.int/emc>

Such a programme must:

- set relevant national objectives consistent with other national health care objectives;
- develop and continually update guidelines for recommended health care surveillance, prevention, and practice;
- develop a national system to monitor selected infections and assess the effectiveness of interventions;
- harmonize initial and continuing training programme for health care professionals;
- facilitate access to materials and products essential for hygiene and safety; and
- encourage health care establishments to monitor health-care associated (nosocomial) infections and to provide feedback to the professionals concerned.

The national or regional health authority should designate an agency to oversee the programme (a ministerial department, institution or other body), and plan national activities with the help of a national expert committee.

- to review risks associated with new technologies, and monitor the risk of acquiring an infection from new devices and products, before their approval for use;
- to review and provide input into investigation of outbreaks and epidemics;
- to communicate and cooperate with other committees of the health care facility with common interests such as Pharmacy and Therapeutics or Antimicrobial Use Committee, Biosafety or Health and Safety Committees, and Blood Transfusion Committee.

Each health care facility needs to develop an infection control programme to ensure the well being of both patients and staff.

Risk prevention for patients and staff is a concern of everyone in the facility, and must be supported by the senior administration. An annual work plan to assess and promote good health care, appropriate isolation, sterilization, and other practices, staff training, and epidemiological surveillance should be developed. Health care facilities must provide sufficient resources to support this programme.

### WHAT IS AN INFECTION CONTROL PROGRAMME?

The important components of the infection control programme are:

- basic measures for infection control, i.e. standard and additional precautions;
- education and training of health care workers;
- protection of health care workers, e.g. immunization;
- identification of hazards and minimizing risks;
- routine practices essential to infection control such as aseptic techniques, use of single use devices, reprocessing of instruments and equipment, antibiotic usage, management of blood/body fluid exposure, handling and use of blood and blood products;
- effective work practices and procedures, such as environmental management practices including management of hospital/clinical waste, support services (e.g., food, linen), use of therapeutic devices;
- surveillance;
- incident monitoring;
- outbreak investigation;
- infection control in specific situations; and
- research.

As well as implementing basic measures for infection control, health care facilities should prioritize their infection control needs and design their programmes accordingly.

### ORGANIZATION OF AN INFECTION CONTROL PROGRAMME

As with all other functions of a health care facility, the ultimate responsibility for prevention and control of infection rests with the health administrator. The hospital administrator/head of hospital should:

- establish an infection control committee which will in turn appoint an infection control team;
- and
- provide adequate resources for effective functioning of the infection control programme.

#### **Infection control committee**

An infection control committee provides a forum for multidisciplinary input and cooperation, and information sharing. This committee should include wide representation from relevant departments: e.g. management, physicians, other health care workers, clinical microbiology, pharmacy, sterilizing service, maintenance, housekeeping and training services. The committee must have a reporting relationship directly to either administration or the medical staff to promote programme visibility and effectiveness.

In an emergency (such as an outbreak), this committee must be able to meet promptly. It has the following tasks:

- to review and approve a yearly programme of activity for surveillance and prevention;
- to review epidemiological surveillance data and identify areas for intervention;
- to assess and promote improved practice at all levels of the health facility;
- to ensure appropriate staff training in infection control and safety management, provision of safety materials such as personal protective equipment and products; and
- training of health workers.

The infection control programme will be effective so long as it is comprehensive and includes surveillance and prevention activities, as well as staff training. There must also be effective support at national and regional levels.

The infection control committee is responsible for the development of policies for the prevention and control of infection and to oversee the implementation of the infection control programme. It should:

- be composed of representatives of various units within the hospital that have roles to play (medical, nursing, engineering, administrative, pharmacy, sterilizing service and microbiology departments);
- elect one member of the committee as the chairperson (who should have direct access to the head of the hospital administration);
- appoint an infection control practitioner (health care worker trained in the principles and practices of infection control, e.g. a physician, microbiologist or registered nurse) as secretary;
- meet regularly (ideally monthly but not less than three times a year);
- develop its own infection control manual/s; and
- monitor and evaluate the performance of the infection control programme.

### **Infection control team**

The infection control team is responsible for the day-to-day activities of the infection control programme. Health care establishments must have access to specialists in infection control, epidemiology, and infectious disease, including physicians and infection control practitioners.

In some countries, these professionals are specialized teams working for a hospital or a group of health care establishments; they may be administratively part of another unit (e.g. a microbiology laboratory, medical or nursing administration, public health services). The optimal structure will vary with the type, needs, and resources of the facility.

The reporting structure must, however, ensure the infection control team has appropriate authority to manage an effective infection control programme. In large facilities, this will usually mean a direct reporting relationship with senior administration. The infection control team or individual is responsible for the day-to-day functions of infection control, as well as preparing the yearly work plan for review by the infection control committee and administration.

These teams or individuals have a scientific and technical support role, e.g. surveillance and research, developing and assessing policies and practical supervision, evaluation of material and products, the overseeing of sterilization and disinfection and the implementation of training

programmes. They should also support and participate in research and assessment programmes at the national and international levels.

The infection control team should:

- consist of at least an infection control practitioner who should be trained for the purpose;
- carry out the surveillance programme;
- develop and disseminate infection control policies;
- monitor and manage critical incidents;
- coordinate and conduct training activities.

### **INFECTION CONTROL MANUAL**

A hospital-associated infection prevention manual containing instructions and practices for patient care is an important tool. The manual should be developed and updated by the infection control team and reviewed and approved by the committee. It must be made readily available for health care workers, and updated in a timely fashion.

### **EDUCATION AND TRAINING OF HEALTH CARE STAFF**

Health administrators should be oriented towards the importance of the infection control programme.

Health care workers should be equipped with requisite knowledge, skills and attitudes for good infection control practices.

The infection control team should:

- assess training needs of the staff and provide required training through awareness programmes, in-service education and on-the-job training;
- organize regular training programmes for the staff for essential infection control practices that are appropriate to their job description;
- provide periodic re-training or orientation of staff; and review the impact of training.

---

## 3. INFECTION CONTROL PRACTICES

Infection control practices can be grouped in two categories

- (1) standard precautions;
- (2) additional (transmission-based) precautions.

Transmission of infections in health care facilities can be prevented and controlled through the application of basic infection control precautions which can be grouped into standard precautions, which must be applied to **all** patients at **all** times, regardless of diagnosis or infectious status, and additional (transmission-based) precautions which are specific to modes of transmission (airborne, droplet and contact).<sup>1,2,3,4,5</sup>

### STANDARD PRECAUTIONS

Treating all patients in the health care facility with the same basic level of "standard" precautions involves work practices that are essential to provide a high level of protection to patients, health care workers and visitors.

These include the following:

- hand washing and antisepsis (hand hygiene);
- use of personal protective equipment when handling blood, body substances, excretions and secretions;
- appropriate handling of patient care equipment and soiled linen;
- prevention of needlestick/sharp injuries;
- environmental cleaning and spills-management; and
- appropriate handling of waste.

#### **Hand washing and antisepsis (hand hygiene)**

Appropriate hand hygiene can minimize micro-organisms acquired on the hands during daily duties and when there is contact with blood, body fluids, secretions, excretions and known and unknown contaminated equipment or surfaces (for further details see Annex 1).

Wash or decontaminate hands:

- after handling any blood, body fluids, secretions, excretions and contaminated items;
- between contact with different patients;
- between tasks and procedures on the same patient to prevent cross contamination between different body sites;
- immediately after removing gloves; and
- using a plain soap, antimicrobial agent or waterless antiseptic agent.

The hospital setting is a good setting for communication about personal hygiene, such as informing visitors and the general public about hygiene rules such as washing hands.

### Use of personal protective equipment

Using personal protective equipment provides a physical barrier between micro-organisms and the wearer. It offers protection by helping to prevent microorganisms from:

contaminating hands, eyes, clothing, hair and shoes;

being transmitted to other patients and staff (for further information about personal protective equipment see Annex 2).

Personal protective equipment includes:

gloves;

protective eye wear (goggles);

mask;

apron;

gown;

boots/shoe covers; and

cap/haircover.

### Examples of personal protective equipment



Gloves



Protective eye wear (goggles)



Masks



### Full Personal Protective Equipment

- Hair cover
- Eye wear (goggles)
- Mask
- Gown
- Apron
- Shoe covers

Personal protective equipment should be used by:

health care workers who provide direct care to patients and who work in situations where they may have contact with blood, body fluids, excretions or secretions;

support staff including medical aides, cleaners, and laundry staff in situations where they may have contact with blood, body fluids, secretions and excretions;

laboratory staff, who handle patient specimens; and

family members who provide care to patients and are in a situation where they may have contact with blood, body fluids, secretions and excretions.

***Principles for use of personal protective equipment***

Personal protective equipment reduces but does not completely eliminate the risk of acquiring an infection. It is important that it is used effectively, correctly, and at all times where contact with blood and body fluids of all patients may occur. Continuous availability of personal protective equipment and adequate training for its proper use are essential. Staff must also be aware that use of personal protective equipment does not replace the need to follow basic infection control measures such as hand hygiene.

The following principles guide the use of personal protective equipment:

Personal protective equipment should be chosen according to the risk of exposure. Health care workers should assess whether they are at risk of exposure to blood, body fluids excretions or secretions and choose their items of personal protective equipment according to this risk.

Avoid any contact between contaminated (used) personal protective equipment and surfaces, clothing or people outside the patient care area.

Discard used personal protective equipment in appropriate disposal bags, and dispose of according to the health care facility protocol.

Do not share personal protective equipment.

Change personal protective equipment completely and thoroughly wash hands each time you leave a patient to attend to another patient or another duty.

**It is important to use personal protective equipment effectively, correctly, and at all times where contact with patient's blood, body fluids, excretions and secretions may occur.**

*Gloves*

Wear gloves (clean, non-sterile) when touching blood, body fluids, secretions, excretions or mucous membranes.

Change gloves between contact with different patients.

Change gloves between tasks/procedures on the same patient to prevent cross contamination between different body sites.

Remove gloves immediately after use and before attending to another patient.

## 4. INFECTION CONTROL PRACTICES

---

Wash hands immediately after removing gloves.

Use a plain soap, antimicrobial agent or waterless antiseptic agent.

Disposable gloves should not be reused but should be disposed of according to the health care facility protocol.

### *Masks*

Wear a mask to protect mucous membranes of the mouth and nose when undertaking procedures that are likely to generate splashes of blood, body fluids, secretions or excretions.

Wear surgical masks rather than cotton, material or gauze masks. Surgical masks have been designed to resist fluids to varying degrees depending on the design of the material in the mask.

Do not reuse disposable masks. They should be disposed of according to the health care facility protocol.

### *Protective eyewear/goggles/visors/face shield*

Wear protective eyewear/goggles/visors/face shields to protect the mucous membranes of the eyes when conducting procedures that are likely to generate splashes of blood, body fluids, secretions or excretions. If disposable, discard appropriately. If they are reusable, decontaminate them according to the manufacturer's instructions.

### *Gowns and plastic aprons*

Wear a gown (clean, non-sterile) to protect the skin and prevent soiling of clothing during procedures that are likely to generate splashes of blood, body fluids secretions or excretions. Impermeable gowns are preferable.

Remove a soiled or wet gown as soon as possible.

A plastic apron may be worn on top of the gown to protect exposure to blood, body fluids, secretions and excretions.

Launder gowns and aprons appropriately if they are reusable, according to the hospital guidelines.

Do not reuse disposable gowns and aprons. They should be disposed of according to the health care facility protocol.

### *Caps and boots/shoe covers*

Wear disposable caps and boots where there is a likelihood the patient's blood, body fluids, secretions or excretions may splash, spill or leak onto the hair or shoes.

Do not reuse disposable caps. They should be discarded according to the health care facility protocol.

Decontaminate reusable boots.

Discard boots/shoe covers after use according to the health care facility protocol.

### ***Handling of patient care equipment and soiled linen***

#### ***Patient care equipment***

Handle patient care equipment soiled with blood, body fluids secretions or excretions with care in order to prevent exposure to skin and mucus membranes, clothing and the environment.

Ensure all reusable equipment is cleaned and reprocessed appropriately before being used on another patient.

#### ***Linen***

Handle, transport and process used linen that is soiled with blood, body fluids, secretions or excretions with care to ensure that there is no leaking of fluid.

### ***Prevention of needle stick/sharps injuries***

Take care to prevent injuries when using needles, scalpels and other sharp instruments or equipment.

Place used disposable syringes and needles, scalpel blades and other sharp items in a puncture-resistant container with a lid that closes and is located close to the area in which the item is used.

Take extra care when cleaning sharp reusable instruments or equipment.

Never recap or bend needles.

*Sharps must be appropriately decontaminated and/or destroyed as per the national standards or guidelines.*

### **Management of health-care waste**

Uncollected, long stored waste or waste routing within the premises must be avoided. A sound waste management system needs to be developed and closely monitored. (For further information see Environmental Management Practices – chapter 4.)

## **ADDITIONAL (TRANSMISSION-BASED) PRECAUTIONS**

Additional (transmission-based) precautions are taken while still ensuring standard precautions are maintained. Additional precautions include:

- airborne precautions;
- droplet precautions; and
- contact precautions.

### **Airborne precautions**

Airborne precautions are designed to reduce the transmission of diseases spread by the airborne route. Airborne transmission occurs when droplet nuclei (evaporated droplets) <5 micron in size are disseminated in the air.<sup>6</sup> These droplet nuclei can remain suspended in the air for long periods of

time. Droplet nuclei are the residuals of droplets and when suspended in the air, dry and produce particles ranging in size from 1-5 micron. These particles can remain suspended indefinitely in the air. Diseases which spread by this mode include open/active pulmonary tuberculosis (TB), measles, chicken pox, pulmonary plague and haemorrhagic fever with pneumonia.

The following precautions need to be taken:

Implement standard precautions.

Place patient in a single room that has a monitored negative airflow pressure, and is often referred to as a "negative pressure room" (see Glossary). The air should be discharged to the outdoors or specially filtered before it is circulated to other areas of health care facility.

Keep doors closed.

Anyone who enters the room must wear a special, high filtration, particulate respirator (e.g. N 95) mask.

Limit the movement and transport of the patient from the room for essential purposes only. If transport is necessary, minimize dispersal of droplet nuclei by masking the patient.

*It is important to gain the support of engineering services to ensure the negative airflow pressure is maintained.*

### **Droplet precautions**

Diseases which are transmitted by this route include pneumonias, pertussis, diphtheria, influenza type B, mumps, and meningitis. Droplet transmission occurs when there is adequate contact between the mucous membranes of the nose and mouth or conjunctivae of a susceptible person and large particle droplets (> 5 microns).<sup>7</sup> Droplets are usually generated from the infected person during coughing, sneezing, talking or when health care workers undertake procedures such as suctioning.<sup>7</sup>

The following precautions need to be taken:

Implement standard precautions.

Place patient in a single room (or in a room with another similarly infected patient).

Wear a mask when working within 1-2 meters of the patient.

Place a mask on the patient if transport is necessary.

Special air handling and ventilation are not required to prevent droplet transmission of infection.

### **Contact precautions**

Diseases which are transmitted by this route include colonization or infection with multiple antibiotic resistant organisms, enteric infections and skin infections.

The following precautions need to be taken:

Implement standard precautions.

Place patient in a single room (or in a room with another similarly infected patient). Consider the epidemiology of the disease and the patient population when determining patient placement.

Wear clean, non-sterile gloves when entering the room.

Wear a clean, non-sterile gown when entering the room if substantial contact with the patient, environmental surfaces or items in the patient's room is anticipated.

Limit the movement and transport of the patient from the room; patients should be moved for essential purposes only. If transportation is required, use precautions to minimize the risk of transmission.

### **PATIENT PLACEMENT AND TRANSPORTATION OF PATIENTS**

#### **Patient placement**

Appropriate or selective placement of patients is important in preventing the transmission of infections in the hospital setting. General principles in relation to the placement of patients include the following.

#### **Spacing between beds**

In open plan wards there should be adequate spacing between each bed to reduce the risk of cross contamination/infection occurring from direct or indirect contact or droplet transmission. Optimum spacing between beds is 1-2 meters.

#### **Single rooms**

Single rooms reduce the risk of transmission of infection from the source patient to others by reducing direct or indirect contact transmission. Where possible, single rooms should have the following facilities:

- hand washing facilities;
- toilet and bathroom facilities.

#### **Anterooms**

Single rooms used for isolation purposes may include an anteroom to support the use of personal protective equipment.

#### **Cohorting**

For infection control purposes, if single rooms are not available, or if there is a shortage of single rooms, patients infected or colonized by the same organism can be cohorted (sharing of room/s).

When cohorting is used during outbreaks, these room/s should be in a well-defined area (a designated room or designated ward), which can be clearly segregated from other patient care areas in the healthcare facility used for non-infected/colonized patients.

#### **Transportation of patients**

Limiting the movement and transport of patients from the isolation room/area for essential purposes only will reduce the opportunities for transmission of micro-organisms in other areas of the hospital.

If transportation is required, suitable precautions should be taken to reduce the risk of transmission of micro-organisms to other patients, health care workers or the hospital environment (surfaces or equipment). For example: when transporting a patient with pulmonary tuberculosis (open/active) placing a mask on the patient while in transit is an appropriate precaution.

---

## 4. ENVIRONMENTAL MANAGEMENT PRACTICES

A clean environment plays an important role in the prevention of hospital-associated infections (HAI).

Many factors, including the design of patient care areas, operating rooms, air quality, water supply and the laundry, can significantly influence the transmission of HAI.

### PREMISES/BUILDINGS

Facility design and planning should ensure:

- adequate safe water supply;
- appropriate cleaning practices;
- adequate floor space for beds;
- adequate interbed space;
- adequate handwashing facilities;
- adequate ventilation for isolation rooms and high risk areas like operation theatres, transplant units, intensive care areas, etc;
- adequate isolation facilities for airborne, droplet, contact isolation and protective environment;
- regulation of traffic flow to minimize exposure of high-risk patients and facilitate patient transport;
- measures to prevent exposure of patients to fungal spores during renovations;
- precautions to control rodents, pests and other vectors; and
- appropriate waste management facilities and practices

### AIR

#### Ventilation

Ventilation systems should be designed and maintained to minimize microbial contamination. The air conditioning filters should be cleaned periodically and fans that can spread airborne pathogens should be avoided in high-risk areas.

High-risk areas such as operating rooms, critical care units and transplant units require special ventilation systems. Filtration systems (air handling units) designed to provide clean air should have high efficiency particulate air (HEPA) filters in high-risk areas. Unidirectional laminar airflow systems should be available in appropriate areas in the hospital construction. Ultra clean air is valuable in some types of cardiac surgery/neurosurgery/implant surgery theatres and transplant units.

For the operating room, the critical parameters for air quality include:

Frequent maintenance / validation of efficacy of filters (in accordance with manufacturer's requirements);

pressure gradient across the filter bed and in the operation theatre;

air changes per hour (minimum 15 air changes per hour);

temperature should be maintained between 20°C and 22°C and humidity between 30% and 60% to inhibit bacterial multiplication;

general areas should be well ventilated if they are not air-conditioned.

### **Special air handling for airborne precautions**

Negative air pressure vented to the air is recommended for contaminated areas and is required also for isolation of patients with infections spread by the airborne route. An air-handling system providing 6-12 air changes per hour with the air being discharged outside through a filtration mechanism is recommended. Systems must be checked by engineering services to ensure they are in fact offering negative pressure rooms.

An air-conditioned single room with an exhaust or a well-ventilated room are adequate options for health care facilities without "negative pressure" rooms. (See also "Negative pressure room" in the glossary.)

### **Protective environment**

A protective environment may be required for some neutropenic patients. Ultra clean unidirectional air may be required in some units such as haematology or intensive care due to the level of immunosuppression of the patients. To minimize airborne particles, air must be circulated into the room with a velocity of at least 0.25m/sec through a high efficiency particulate air (HEPA) filter. The HEPA filter removes particles to a certain defined size. If particles 0.3 microns in diameter are removed, the air entering the room can be classified as being clean and free of bacterial contamination.<sup>2</sup>

Other important ways of protecting patients with severely lowered immune systems include:

Health care workers and visitors should avoid contact with the patient if they have any infections (for example, upper respiratory tract infections or herpes simplex blisters).

Where appropriate, staff and visitors should wear personal protective equipment to protect the patient from micro-organisms.

Do not put flowers in the room.

Ensure a tidy environment.

Environmental cleaning should be done twice daily and should consist of damp dusting only – do not create aerosols.

Use strict aseptic techniques for all clinical procedures.

### **WATER**

The health care facility should provide safe water. If it has water storage tanks, they should be cleaned regularly and the quality of water should be sampled periodically to check for bacterial contamination.

#### **Safe drinking water**

Where safe water is not available, boil water for 5 minutes to render it safe. Alternatively, use water purification units.

Store water in hygienic environment. Do not allow hands to enter the storage container.

Dispense water from storage container by an outlet fitted with a closure device or tap.

Clean the storage containers and water coolers regularly.

### **CLEANING THE HOSPITAL ENVIRONMENT**

Routine cleaning is important to ensure a clean and dust free hospital environment. There are usually many micro-organisms present in “visible dirt”, and routine cleaning helps to eliminate this dirt. Administrative and office areas with no patient contact require normal domestic cleaning. Most patient care areas should be cleaned by wet mopping. Dry sweeping is not recommended. The use of a neutral detergent solution improves the quality of cleaning. Hot water (80°C) is a useful and effective environmental cleaner. Bacteriological testing of the environment is not recommended unless seeking a potential source of an outbreak.

Any areas with visibly contaminated with blood or body fluids should be cleaned immediately.

Isolation rooms and other areas that have patients with known transmissible infections should be cleaned with a detergent/disinfectant solution at least daily.

All horizontal surfaces and all toilet areas should be cleaned daily.

### **WASTE MANAGEMENT**

Hospital waste is a potential reservoir of pathogenic micro-organisms and requires appropriate safe and reliable handling. The main risk associated with infection is sharps contaminated with blood.<sup>2</sup> There should be a person or persons responsible for the organization and management of waste collection, handling, storage and disposal. Waste management should be conducted in coordination with the infection control team.

Waste management practices must meet national and local requirements; the following principles are recommended as a general guide.

### Principles of waste management

Steps in the management of hospital waste include:

- generation,
- segregation/separation,
- collection,
- transportation,
- storage,
- treatment,
- final disposal.

Develop a waste management plan that is based on an assessment of the current situation and minimizes the amount of waste generated.

Segregate clinical (infectious) waste from non-clinical waste in dedicated containers.

Transport waste in a dedicated trolley

Store waste in specified areas with restricted access.

Store sharps in sharps containers

Sharps containers should be made of plastic or metal and have a lid that can be closed. They should be marked with the appropriate label or logo, e.g. a biohazard symbol for clinical (infectious) waste (see picture below).



Biohazard symbol

Mark the storage areas with a biohazard symbol.

Ensure that the carts or trolleys used for the transport of segregated waste collection are not used for any other purpose – they should be cleaned regularly.

Identify a storage area for waste prior to treatment or to final disposal area

### Treatment of hazardous and clinical /infectious waste

Each health care facility should identify a method for the treatment of clinical /infectious waste. This may consist of transportation of infectious waste to a centralized waste treatment facility or on-site treatment of waste.

### Methods of disposal

Sharps

- Puncture-proof containers which can be autoclaved, shredded and land-filled or microwaved, shredded and land-filled or treated by plasma pyrolysis.

- Deep burial in a secure area. Burial should be 2 to 3 meters deep and at least 1.5 meters above the groundwater table.

##### Waste requiring incineration

- Anatomical parts and animal carcasses.
- Cytotoxic drugs (residues or outdated).
- Toxic laboratory chemicals other than mercury.

##### Waste that may be incinerated

- Patient-contaminated non-plastics and non-chlorinated plastics.
- Anatomical parts and animal carcasses.

##### Waste that should not be incinerated

- Chlorinated plastics.
- Volatile toxic wastes such as mercury.
- Plastics, non-plastics contaminated with blood, body fluids, secretions and excretions and infectious laboratory wastes. (Such wastes should be treated by steam sterilization in autoclavable bags or microwave treatment. Shredding may follow both these methods. If neither method is available, chemical treatment with 1% hypochlorite or a similar disinfectant is recommended. However, excessive use of chemical disinfectants should be avoided as it may be a health and environmental hazard.)

Radioactive waste (should be dealt with according to national laws).

For further details please refer to WHO's *Safe management of wastes from health-care activities* (1999) at: [http://www.who.int/water\\_sanitation\\_health/medicalwaste/wastemanag/en/](http://www.who.int/water_sanitation_health/medicalwaste/wastemanag/en/)

**Practical classification of hospital waste and methods of treatment**

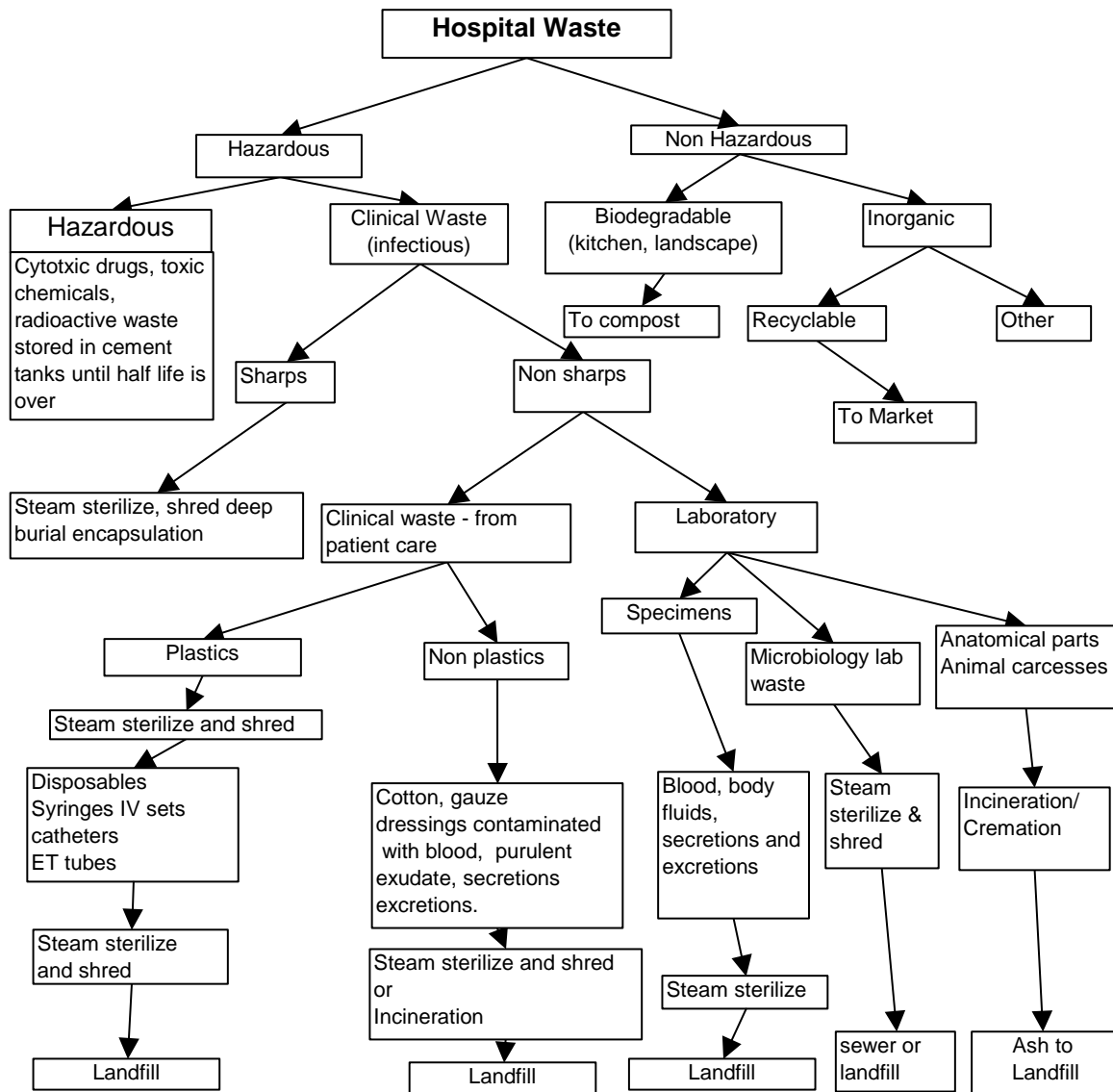

### LAUNDRY

Two categories of used linen are recognized. Where there is visible contamination by blood, body fluids, secretions and excretions, this may be called “soiled” or “contaminated”. Other used linen is termed “used”. These two categories should be segregated and treated separately.

#### General instructions

Handle all linen with minimum agitation to avoid aerosolisation of pathogenic micro-organisms.

Place soiled/contaminated linen in impervious bags for transportation to avoid any spills or drips of blood, body fluids, secretions or excretions

Disinfect by using hot water and/or bleach (use heavy-duty gloves, eye protection and masks to protect against splashes).

Autoclave linen before being supplied to the operating rooms/theatres and high-risk areas, e.g. burns units and transplant units.

Wash linen (sheets, cotton blankets) in hot water (70°C to 80°C) and detergent, rinse and dry preferably in a dryer or in the sun. (Heavy-duty washers/dryers are recommended for the hospital laundry.)

Wash woollen blankets in warm water and dry in the sun, in dryers at cool temperatures or dry-clean.

When laundering linen from an isolation room do not sort, shake, or handle excessively.

#### Bedding

Mattresses and pillows with plastic covers should be wiped over with a neutral detergent

Mattresses without plastic covers should be steam cleaned if they have been contaminated with body fluids.

Wash pillows either by using the standard laundering procedure described above, or dry clean if contaminated with body fluids.

### REPROCESSING OF INSTRUMENTS AND EQUIPMENT<sup>3</sup>

The risk of transferring infection from instruments and equipment is dependent on the following factors:

1. the presence of micro-organisms, the number and virulence of these organisms;
2. the type of procedure that is going to be performed; invasive or non-invasive, and
3. the body site where the instrument/and or equipment will be used; penetrating the mucosal tissue or used on intact skin.

The classification of risk of transmission of infection by instruments and equipment has been called the "Spalding Classification"<sup>8</sup>. The risk of transmission is classified according to the site where the instrument is to be used. Contact sites for instruments may be classified as critical, semi critical or non-critical. Table 1 shows these classifications. The level of reprocessing required is based on the classification and level of risk. Any instrument or equipment entering into a sterile part of the body must be sterilized. Where the instrument or equipment will be in contact with mucous membranes or nonintact skin, it must have undergone high-level disinfection, and where there will be contact with intact skin, a low level of disinfection or cleaning should be used.<sup>3</sup>

**Table 1. Level of disinfection required for patient care equipment<sup>2,3,8</sup>**

Application	Classification	Level of risk	Level of reprocessing required	Example	Storage of reprocessed instrument
Entry or penetration into sterile tissue, cavity or bloodstream Eg. Into vascular system Into sterile cavity Into sterile tissue	Critical	High	Sterile <i>Sterilization by steam under pressure or an automated low-temp chemical sterilant system, other liquid chemical sterilant or ethylene oxide sterilization.</i>	Surgical procedure Entry into sterile tissue arthroscopes, biopsies Intravascular cannulation	Sterility must be maintained. <ul style="list-style-type: none"> <li>packaged items must be allowed to dry before removal from the sterilizer</li> <li>the integrity of the wrap must be maintained</li> <li>wraps should act as effective biobarrier during storage</li> <li>store away from potential environmental contaminants</li> <li>unpackaged sterile items must be used immediately</li> </ul>
Contact with intact nonsterile mucosa or nonintact skin	Semi-critical	Medium	High level disinfection <i>Heat tolerant items</i> <ul style="list-style-type: none"> <li>steam sterilize where possible</li> <li>if unable to steam sterilize– use thermal disinfection</li> </ul> <i>Heat-sensitive items</i> <ul style="list-style-type: none"> <li>low temperature automated chemical sterilant systems</li> <li>high level chemical disinfectant</li> </ul>	Respiratory therapy gastroscopy	Store to protect from environmental contaminants
Intact skin No contact with the patient	Noncritical	Low	Items must be clean <ul style="list-style-type: none"> <li>Clean after each use with detergent and water.</li> <li>if disinfection is required follow with appropriate disinfectant, e.g. 70% alcohol.</li> </ul>	Beds, sinks, etc	Store in a clean dry place

Reprocessing of instruments and equipment in an effective way includes

1. cleaning instruments and equipment immediately after use to remove all organic matter, chemicals and
2. disinfection (by heat and water or chemical disinfectants) or
3. sterilization.

For more information on the selection and use of disinfectants see APIC Guideline for selection and use of disinfectants (1996.)<sup>9</sup>

### **Reprocessing principles<sup>3</sup>**

There are certain principles that must be applied to ensure instruments and equipment have been appropriately reprocessed.

#### 1. Staff training.

Staff who work in the sterilizing service department and are responsible for the reprocessing of instruments and equipment must have undergone formal training in how to clean, disinfect and sterilize instruments and equipment. The level of training must be appropriate for the level of responsibility that the staff member is expected to undertake.

#### 2. Appropriate level of reprocessing

As described above, it is essential that the correct level of reprocessing of an instrument/equipment is chosen according to its intended use. This decision is made not according to what the instrument or equipment is, but rather what its intended use is.

Steam sterilization is recommended as the most effective way of achieving sterility. However, this may not always be possible as some instruments may not be able to withstand the temperature or moisture required for sterilization using steam. Other methods may be used to achieve sterility such as ethylene oxide or automated low temperature chemical sterilant systems, providing the manufacturer of the instrument/equipment agrees that this is an effective means to sterilize or provide high-level disinfection to them. Under a new system in the European Union, manufacturers of reusable medical devices will need to provide reprocessing instructions when items are purchased.

#### 3. Servicing of instruments and equipment

Before sending medical devices for service they should be reprocessed appropriately. If however, they are unable to be reprocessed before being repaired, they should be placed in a fluid-resistant plastic bag or container and labelled appropriately before being sent for repair.

#### 4. Selected items that require special reprocessing.

Items that require special treatment include:

- endoscopes
- respiratory and anaesthetic apparatus
- diagnostic ultrasonic transducers

Instruments and equipment such as these may not be able to withstand the heat or the moisture of steam or thermal disinfection or even some chemical agents. They therefore may require very delicate measures to reprocess them. It is essential that equipment that will not withstand the regular types of reprocessing must be reprocessed only in a department that has the proper reprocessing facilities. The manufacturer's instructions must be followed.

### 5. Storage

Storage of instruments and equipment is an essential component in ensuring the product maintains its level of sterility or high-level disinfection. Most instruments and equipment are dry and packaged once they have been sterilized. They should be stored in a clean, dry environment and protected from any object that may cause them damage. Correct storage of sterile instruments and equipment is a critical component in keeping them sterile.<sup>3</sup>

### 6. Patient care equipment

Any equipment that is used for patients, and touches only their intact skin, such as bedpans, urinals, commode chairs, blood pressure cuffs etc. should be cleaned and disinfected – usually in hot water (at least 70°C).

## CLEANING, DISINFECTION AND STERILIZATION

### Cleaning

Prior to any reprocessing to achieve disinfection or sterility all instruments and equipment **MUST** be cleaned. If they are not cleaned properly, organic matter may prevent the disinfectant or sterilant from having contact with the instrument/equipment and may also bind and inactivate the chemical activity of the disinfectant.<sup>10</sup> If an instrument/equipment cannot be cleaned, then it cannot be sterilized or disinfected.

After an instrument has been used, before it dries, it should be washed to remove any gross soiling. At this stage, detergent and water is appropriate to use.

There are four main methods for cleaning of instruments and equipment:

#### 1. Manual cleaning

All surfaces of the instrument/equipment **MUST** be cleaned, taking care to reach all channels and bores of the instrument. If instruments are being washed manually the following procedure should be followed:

- wear personal protective equipment (plastic apron, thick rubber gloves, eye protection, mask and/or face shield)
- remove any gross soiling on the instrument by rinsing in tepid water (15-18 degrees)
- take instrument fully apart and immerse all parts in warm water with a biodegradable, noncorrosive, nonabrasive, low foaming and free rinsing detergent or use an enzymatic cleaner if necessary
- ensure all visible soil is removed from the instrument – follow manufacturer's instructions

- rinse in hot water (unless contraindicated)
- dry the instrument either in drying cabinet, or hand dry with clean lint-free cloth
- inspect to ensure the instrument is clean

#### 2. Enzymatic cleaners

Used for fiberoptic instruments and accessories, and other items that are difficult to clean. These products are hazardous and care should be taken when in contact with them.

#### 3. Ultrasonic cleaners and automated washers

Ultrasonic cleaners and automated washers are recommended for cleaning basic instruments that can withstand this process. Using a machine to wash the instruments will cut down on the handling of the instruments. These cleaners must be compliant with national guidelines and standards, and must be used according to the manufacturer's instructions. Ultrasonic cleaners DO NOT disinfect the instruments. By causing high-frequency, high-energy sound waves to hit the instrument/equipment, the soiling matter drops off the instrument and onto the bottom of the compartment, or loosens the soil enough so that it will be removed during the rinsing process.

These cleaners are not appropriate for use on cannulated instruments (they cannot clean inside the instrument), plastic materials, two or more different metals, or some glass instruments, syringes and lenses. Daily efficiency tests should be done.<sup>3</sup>

### **Disinfection**

Disinfection removes micro-organisms without complete sterilization. Disinfection is used to destroy organisms present on delicate or heat-sensitive instruments which cannot be sterilized or when single use items are not available. Disinfection is not a sterilizing process and must not be used as a convenient substitute for sterilization. Thermal disinfection is not appropriate for instruments that will be used in critical sites (see Table 1) as these instruments must be sterile.

Certain products and processes will provide different levels of disinfection. These levels are classified as:<sup>2,3</sup>

- (1) **High-level disinfection** (classed as critical in Table 1). Destroys all micro-organisms except some bacterial spores (especially if there is heavy contamination).
- (2) **Intermediate disinfection** (classed as semi-critical in Table 1). Inactivates *Mycobacterium tuberculosis* vegetative bacteria, most viruses and most fungi, but does not always kill bacterial spores.
- (3) **Low-level disinfection** (classified as non-critical). Can kill most bacteria, some viruses and some fungi, but cannot be relied on to kill more resistant bacteria such as *M. tuberculosis* or bacterial spores.

The two methods of achieving disinfection are thermal and chemical disinfection.

#### 1. Thermal disinfection (pasteurisation)

If an instrument is able to withstand the process of heat and moisture and is not required to be sterile, then thermal disinfection is appropriate. By using heat and water at temperatures and times that destroy pathogenic, vegetative agents this is a very efficient method of disinfection.

The level of disinfection depends on the water temperature and the time the instrument is exposed to that temperature

**Table 2. Minimum surface temperature and time required for thermal disinfection<sup>3</sup>**

Surface temperature (°C)	Minimum disinfection time required (minutes)
90	1
80	10
75	30
70	100

## 2. Chemical disinfection

The performance of chemical disinfectants is dependent on a number of factors including; temperature, contact time, concentration, pH, presence of organic or inorganic matter and the numbers and resistance of the initial bioburden on a surface.<sup>3</sup>

Instrument grade disinfectants are classified as high, intermediate or low level. When used according to the manufacturer's guidelines disinfectants will fall into one of these levels – see Table 3.

**Table 3. Chemical disinfectant – level of disinfection achieved<sup>3</sup>**

Level of disinfection	Activity against microbes
High-level chemical disinfectant	Inactivates all microbial pathogens except where there are large numbers of bacterial spores
Intermediate-level disinfectant	Inactivates all microbial pathogens except bacterial endospores
Low-level disinfectant	Rapidly inactivates most vegetative bacteria as well as medium sized lipid containing viruses, but may not destroy bacterial endospores, mycobacteria, fungi or small nonlipid viruses.

## **Selection of disinfectant**

There is no single ideal disinfectant. Different grades of disinfectants are used for different purposes. Only instrument grade disinfectants are suitable to use on medical instruments and equipment. Hospital grade or household grade disinfectants must not be used on instruments, they are only suitable for environmental purposes.

Monitoring of the disinfectant is important if it is a multi-use solution. It is important that it is stored correctly and according to the manufacturers instructions. Be sure not to contaminate the solution when pouring out for use.

Glutaraldehyde is the generally the most appropriate chemical disinfectant that will provide high-level disinfection. This chemical must be used under very strict controlled conditions and in a safe working environment. Glutaraldehyde 2% is appropriate high level disinfectant for endoscopes, respiratory therapy equipment and for materials that are destroyed by heat. An immersion time of  $\geq 20$  mins. Flexible endoscopes are particularly difficult to disinfect and very easy to damage. It is extremely important that meticulous mechanical cleaning MUST always precede sterilization or disinfection procedures. See the APIC Guideline for selection and use of disinfectants (1996.)<sup>9</sup>

### **Sterilization**

Sterilization is the destruction of all micro-organisms and can be achieved by either physical or chemical methods.<sup>2</sup> Sterilization is necessary for medical devices penetrating sterile body sites. (see Table 1). Cleaning to remove visible soiling in reusable equipment should precede sterilization. All materials must be wrapped before sterilization. Only wrapped/packed sterilized materials should be described as sterile. Before any instrument or equipment goes under the process of steam sterilization, the following should be checked:

1. ensure that the instrument can withstand the process (e.g. steam under pressure)
2. ensure that the instrument has been adequately cleaned;
3. ensure that the instrument does not require any special treatment;
4. ensure that records are kept of the sterilisation and traceability of the instrument.

Instruments and equipment will be sterile only if one of the following sterilizing processes is used.

1. steam under pressure (moist heat);
2. dry heat;
3. ethylene oxide;
4. automated environmentally sealed low-temperature peracetic acid, hydrogen peroxide plasma and other chemical sterilant systems or sterilants; and
5. irradiation.

The above sterilizing methods are designed to give a sterility assurance level of at least  $10^{-6}$  (see glossary) as long as the process is validated and is according to the manufacturer's guidelines.

Ultraviolet light units, incubators, microwave ovens, domestic ovens and pressure cookers must not be used for sterilizing.

#### 1. Steam under pressure (moist heat) sterilization<sup>3</sup>

This is the most efficient and reliable ways of achieving sterility of instruments and equipment. This method sterilizes and dries the sterile package as part of the cycle. This is recommended in the office based practice. There are several types of steam under pressure sterilizers (previously called autoclaves).

Downward gravity displacement – jacketed and nonjacketed. These are designed for the sterilization of waste, solutions and instruments.

Self-contained (benchtop) – these are recommended for the office based practice as they are able to do small quantities or fairly simple items. Benchtop sterilisers do not take wrapped items and therefore items must be used immediately after they are removed from the sterilizer. There will be differences in the models and types of features that are offered may vary. These may include; drying stage, ability to take packaged and unwrapped items, systems to monitor temperature, pressure and holding time.

Prevacuum (porous load) and Operator convertible.

### 2. Dry heat sterilization<sup>3</sup>

Dry heat sterilization is caused by hot air that destroys pathogens through oxidation. Dry heat sterilizers have had limited value because it is difficult to maintain the same temperature throughout the load, while the high temperatures and long times required to achieve sterility makes this method undesirable for many situations. The manufacturer's instructions must be followed, the door to the unit must not be opened while the machine is in sterilizing cycle.

### 3. Ethylene oxide (EO)<sup>3</sup>

Ethylene oxide gas is appropriate to use for sterilization of instruments or equipment made from heat labile materials or devices that contain electronic components. The time required to process the instrument is dependent on the temperature, humidity and concentration level of the gas. The gas must penetrate the packaging and reach all surfaces of the instrument or equipment requiring sterilization. The usual time for such a process is between 12 hours and more than 24 hours. Because EO is toxic this gas is restricted in health care facilities and must be used according to strict guidelines to ensure staff safety. The manufacturer's instructions must be followed for the packaging, sterilization process, validation with *Bacillus subtilis* and aeration process.

### 4. Automated chemical (low temperature) systems<sup>3</sup>

Hydrogen peroxide plasma in a fully automated cycle can achieve low temperature, low moisture sterilization within a 45-80 minute cycle depending on the model of sterilizer used. The packaging used must be non-woven/non-cellulose polypropylene wraps

Peracetic acid is a low-temperature sterilization method. Peracetic acid 0.2% is placed in an environmentally sealed chamber and fully automated processing system. The process achieves moist, low temperature sterilization within 25-30 minutes. Items are sterilized in special containers.

### 5. Irradiation

Gamma radiation is available from some commercial gamma irradiation facilities, however it is not readily available for use in health care facilities.

Only those instruments and equipment that have undergone the entire sterilizing process can be regarded as sterile. Items must be wrapped or packaged appropriately to be considered sterile.<sup>2</sup>

Materials for packaging include:

Paper. This prevents contamination if it remains intact. It maintains sterility for a long period, can act as a sterile field and can also be used to wrap dirty devices after the procedure.

Non-woven disposable textiles.

Containers. These can be used only if they contain material intended for a single treatment procedure for a single patient.

The end-user must check the physical integrity of the package before use.

Quality control parameters for the sterilization process which also serve as a check list for the Sterilization Department include:

- load number,
- load content,
- temperature and time exposure record chart,
- physical/chemical testing,
- biological testing.

Regular engineering maintenance on sterilization equipment must be performed and documented.

For details refer to Young, Jack H. and Reichert, Marimargaret. *Sterilization Technology for the Health Care Facility*, 2 ed. New York, USA, Aspen Publishers, 1997.

Boiling of medical devices for reuse is not recommended since it does not guarantee sterility.

However, in certain resource-poor situations where steam sterilization is not possible, these items should be thoroughly cleaned and subjected to a cycle in a pressure cooker for 30 minutes.

**Special consideration – CJD<sup>3</sup>**

The only infectious agent that requires special treatment in order to ensure decontamination is the CJD prion. Historically, CJD has been transmitted through implanted brain electrodes that were disinfected with ethanol and formaldehyde after use on a patient known to have CJD. Iatrogenic transmission has been observed in some patients who have been recipients of contaminated human growth hormone, gonadotropin and corneal, pericardial and dura mater grafts.<sup>9</sup> These prions resist normal inactivation methods; The preferred method is steam sterilization for at least 30 minutes at a temperature of 132°C in a gravity displacement sterilizer when material has been contaminated. If a prevacuum sterilizer is used, 18 minutes at 134°C has been found to be effective. Semi-critical and noncritical items may be immersed in 1N sodium hydroxide, a caustic solution, for 1 hour at room temperature and then steam sterilized for 30 minutes at a temperature of 121 °C.

**Table 4. Common disinfectants used for environmental cleaning in hospitals**

Disinfectants	Recommended use	Precautions
<b>Sodium hypochlorite</b> 1% in-use dilution, 5% solution to be diluted 1:5 in clean water	Disinfection of material contaminated with blood and body fluids	<ul style="list-style-type: none"> <li>• Should be used in well-ventilated areas</li> <li>• Protective clothing required while handling and using undiluted</li> <li>• Do not mix with strong acids to avoid release of chlorine gas</li> <li>• Corrosive to metals</li> </ul>
<b>Bleaching powder</b> 7g/litre with 70% available chlorine Table 6 shows dilutions for bleach	Toilets / bathrooms - may be used in place of liquid bleach if this is unavailable	Same as above
<b>Alcohol (70%)</b> Isopropyl, ethyl alcohol, methylated spirit.	Smooth metal surfaces, tabletops and other surfaces on which bleach cannot be used.	<ul style="list-style-type: none"> <li>• Flammable, toxic, to be used in well-ventilated area, avoid inhalation</li> <li>• Kept away from heat source, electrical equipment, flames, hot surfaces</li> <li>• Allow it to dry completely, particularly when using diathermy as it can cause diathermy burns</li> </ul>
<b>Detergent with enzyme</b>	Cleaning endoscopes, surgical instruments before disinfection is essential	Manual cleaning is an essential part of the cleaning process

**Table 5. Common disinfectants/antiseptics used for skin cleansing**

Disinfectants	Recommended use	Precautions
<b>Chlorhexidine</b> Combined with alcohol or detergents	Antiseptic, for skin and mucous membranes, preoperative skin preparation, disinfection of hands	<ul style="list-style-type: none"> <li>Inactivated by soap, organic matter</li> <li>Relatively nontoxic</li> <li>Do not allow contact with brain meninges, eye or middle ear</li> </ul>
<b>Quaternary ammonium compounds</b>  e.g. Dettol May be combined with chlorhexidine	Antiseptic, for cleaning dirty wounds	<ul style="list-style-type: none"> <li>Relatively nontoxic</li> <li>dilutions are likely to get contaminated and grow gram negative bacteria</li> </ul> Hence: <ul style="list-style-type: none"> <li>Use in correct dilution and only pour enough solution for single patient use</li> <li>Discard any solution that is left over after single use</li> <li>Do not top up stock bottle</li> </ul>

**Hypochlorite solutions:** In some resource-poor situations, hypochlorite solutions are the only available disinfectant. These solutions will need to be diluted so that they make up the appropriate dilution of 0.5%, 1% and 2% available chlorine. The dilution of hypochlorite solution is outlined in Table 6.

**Table 6. Hypochlorite solution of 0.5%, 1% and 2% available chlorine**

Product	Chlorine available	How to dilute to 0.5%	How to dilute to 1%	How to dilute to 2%
Sodium hypochlorite – liquid bleach	3.5%	1 part bleach to 6 parts water	1 part bleach to 2.5 parts water	1 part bleach to 0.7 parts water
Sodium hypochlorite – liquid	5%	1 part bleach to 9 parts water	1 part bleach to 4 parts water	1 part bleach to 1.5 parts water
NaDCC (sodium dichloroisocyanurate) -- powder	60%	8.5 grams to 1 litre water	17 grams to 1 litre water	34 grams to 1 litre water
NaDCC (1.5g / tablet) -- tablets	60%	6 tablets to 1 litre water	11 tablets to 1 litre water	23 tablets to 1 litre water
Chloramine -- powder	25%	20 grams to 1 litre water	40 grams to 1 litre water	80 grams to 1 litre water

**Note:** Bleach solution becomes unstable rapidly, hence it needs to be freshly prepared daily or changed on becoming dirty/turbid. Chlorine bleach can be corrosive. Protect metal instruments by thoroughly rinsing them with water after soaking for 10 minutes.

For further information about preparing bleach solutions for disinfection purposes in resource-poor areas, please view the WHO and CDC combined document "Infection Control for Viral Haemorrhagic Fevers in the African Health Care Setting." (1998) <http://www.cdc.gov/ncidod/dvrd/spb/mnpages/vhfmanual.htm>

#### 4. ENVIRONMENTAL MANAGEMENT PRACTICES

**Table 7. Standard procedure for cleaning and disinfection of reusable equipment**

**Used personal protective equipment**

Equipment	Standard procedure	Comments
Apron Use of disposable apron is recommended	If reusable: clean with detergent and water, dry, disinfect with 70% alcohol	If disposable: discard in appropriate waste bag according to the health care facility guidelines
N 95 or standard surgical mask Use disposable mask only		Discard in appropriate waste bag according to the health care facility guidelines
HEPA (P100) mask Use disposable filters only	Separate the filters from the mask and discard the filter Clean the mask with detergent and water, dry and disinfect with 70% alcohol before reuse	Discard the filters in appropriate bag according to the health care facility guidelines
Eye protector/goggles/face shield Use of disposable goggles is recommended	If reusable: clean with detergent and water, dry, and disinfect with 70 % alcohol or soak in 1% hypochlorite solution for 20 minutes and rinse and dry.	If disposable: discard in appropriate waste bag according to the health care facility guidelines
Gown Use of disposable gown is recommended	If reusable: launder as per the health care facility guidelines for soiled linen For example: launder in hot water (70° - 80° C) if possible  OR Soak in clean water with bleaching powder 0.5% for 30 minutes Wash again with detergent and water to remove the bleach	If disposable: discard in appropriate waste bag according to the health care facility guidelines  If reusable: ideally dry in a clothes drier or in the sun
Cap Use of disposable cap is recommended	If reusable: launder as per the health care facility guidelines for soiled linen For example: launder in hot water (70° - 80° C) if possible OR Soak in clean water with bleaching powder 0.5% for 30 minutes Wash again with detergent and water to remove the bleach	If disposable: discard in appropriate waste bag Seal the bag  If reusable: ideally dry in a clothes drier or in the sun
Gloves Use disposable gloves only		Discard in the appropriate waste bag according to the health care facility guidelines

**Soiled linen**

Equipment	Standard procedure	Comments
Linen	If reusable: launder as per the institutional guidelines for soiled linen For example: launder in hot water (70° - 80° C) if possible  OR Soak in clean water with bleaching powder 0.5% for 30 minutes Wash again with detergent and water to remove the bleach	Ideally dry in a clothes drier or in the sun
Mops wash mops separately from other linen	If reusable: launder as per the institutional guidelines for soiled linen For example: launder in hot water (70° - 80° C) if possible  OR Soak in clean water with bleaching powder 0.5% for 30 minutes Wash with detergent and water to remove the bleach	Mops should not be left wet Mops should be changed: (1) routinely and immediately following the cleaning of blood, body fluids secretions and excretions, (2) after cleaning a contaminated area, operating rooms or isolation rooms. Store dry

**Soiled patient care equipment (needles, syringes, surgical instruments and other equipment) used for patient**

Equipment	Standard procedure	Comments
Needles and syringes <b>Use disposable only</b>	Discard in puncture-proof container with international biohazard symbol	When puncture proof container is two thirds full, seal it and send for disposal Needle destroyer is not recommended for preventing aerosol which may arise while destroying the needles Syringe cutter is not recommended as it can cause splashes
Soiled patient care equipment stethoscope, blood pressure apparatus	Clean with detergent and water and dry May be wiped with sodium hypochlorite 1-2% or 70% alcohol and dried after cleaning	Always clean in between patient use
Cuffs of blood pressure apparatus	Clean with soap and water followed by appropriate disinfectant For example, wash in hot water with detergent If material is not washable, wipe with sodium hypochlorite 1-2% or 70% alcohol and dry after cleaning	Ideally dry in sun after washing  If set aside for isolation room. Should remain in the isolation room until discharge of the patient when it must be decontaminated appropriately
Instruments	Remove all protein, organic, inorganic matter at point of generation (e.g. blood and body secretions) by cleaning with soap and water Return to the sterilizing service department for appropriate reprocessing	
AMBU bag and mask	Clean with detergent, dry and send to the sterilizing service department sterilize	Change mask after each patient

#### 4. ENVIRONMENTAL MANAGEMENT PRACTICES

##### Equipment in the isolation unit (tables, beds, lockers, trolleys, etc)

Equipment	Standard procedure	Comments
Furniture – bed, bed stand, couch, frames, table, I/V stand, wheelchair, etc.	Clean with detergent and water and dry Wipe with disinfectant such as 70% alcohol or 1% sodium hypochlorite and dry after cleaning	Keep environment clean
Mattress/pillows (always cover with plastic bags)	Clean with detergent and water between patients and as required Wipe over with disinfectant such as 70% alcohol or 1% sodium hypochlorite	Discard pillow if cover of pillow is damaged Change the cover of the mattress if torn or discard mattress depending on the institutional guidelines
Telephones, dressing trolleys	Clean with detergent and water, and dry Disinfect with 70% alcohol daily	
Ventilator, suction equipment and mask	Clean machine with detergent and water, dry, and disinfect with 70% alcohol Filters should be single use and discarded Mask is single patient use and should be cleaned at least daily and also as it becomes soiled	Discard mask after each use Change tubing/filters every 48 hours Ensure tubing is single patient use
Toys	Use for one single patient Clean with detergent and water, and dry. If micro-organism is transmitted via contact transmission such as SARS, VHF, MRSA, VRE, wipe with disinfectant or 1-2% hypochlorite solutions	If patient has communicable disease or micro-organism that is transmitted via contact transmission such as SARS, VHF, MRSA and is unable to be cleaned, destroy after the discharge or death of the patient.

##### Environmental surfaces in the patient's room

Equipment	Standard procedure	Comments
Floor	Damp mop with detergent and water	Clean twice in each shift and more often if needed
Spillage – of blood, body fluids, secretions and excretions	Wipe with paper towel or reusable cloth to soak up the majority of the spill Clean with detergent and water Dry the area	Discard paper towel into clinical (infectious) waste If using reusable cloth – separate into contaminated linen bag
Commode toilet seats	Clean seat and arms with detergent and water and dry whenever used Wipe with disinfectant for example 1-2% sodium hypochlorite and dry after cleaning	Whenever soiled, clean with detergent first and then wipe with disinfectant, for example. Sodium hypochlorite-1-2% and dry after cleaning

**Keep used dirty items separate from clean and sterile ones to prevent cross-contamination**

## **5. CARE OF HEALTH CARE WORKERS<sup>2</sup>**

Health care workers (HCW) are at risk of acquiring infection through occupational exposure.<sup>2</sup> Hospital employees can also transmit infections to patients and other employees. Thus, an employees' health programme must be in place to prevent and manage infections in hospital staff.

Employees' health should be reviewed at recruitment, including immunization history and previous exposures to communicable diseases (e.g. tuberculosis) and immune status. Some previous infections such as varicella-zoster virus may be assessed by serological tests.

Immunization recommended for staff includes: hepatitis A and B, influenza, measles, mumps, rubella, tetanus, and diphtheria. Immunization against varicella, rabies may be considered in specific cases. The Mantoux skin test will document a previous tuberculosis (TB) exposure.

Specific post-exposure policies must be developed, and compliance ensured for a number of infectious diseases for example: human immunodeficiency virus (HIV), viral hepatitis, severe acute respiratory syndrome (SARS), varicella, rubella and tuberculosis.

Health care workers with infections should report their illnesses/incident to staff clinics for further evaluation and management.

### **EXPOSURE TO HUMAN IMMUNODEFICIENCY VIRUS (HIV)**

The route of transmission for HIV is person to person via: sexual contact, sharing of needles contaminated with HIV, infusions that are contaminated with HIV, transplantation of organs or tissues that are infected with HIV.<sup>11</sup> The risk of a health care worker acquiring HIV after a needlestick or other "sharps" injury is less than 0.5%.<sup>11</sup> Risk reduction must be undertaken for all bloodborne pathogens, including: adherence to standard precautions using personal protective equipment and appropriate use of safety devices and a needle disposal system to limit sharps exposure. Training for health care workers in safe sharps practice should be ongoing.

Information on preventive measures must be provided to all staff with potential exposure to blood and blood products. Policies which are in keeping with the local and national guidelines must include screening of patients, disposal of sharps and wastes, protective clothing, managing inoculation accidents, sterilization and disinfection.

Hospital policy must include measures to obtain serological testing of source patients promptly where necessary, usually with the patient's informed consent. Post exposure prophylaxis should be started as per local or national guidelines.

### **EXPOSURE TO HEPATITIS B VIRUS**

The route of transmission for Hepatitis B virus is through body substances such as blood and blood products, saliva, cerebrospinal fluid, peritoneal, pleural, pericardial and synovial fluid, amniotic fluid, semen and vaginal secretions and any other body fluid containing blood.<sup>11</sup> Following standard

precautions is important, but immunization is the best way of preventing transmission to health care staff.

All HCWs at risk must be vaccinated.

Staff infected with bloodborne pathogens may transmit these infections to patients and require careful evaluation with respect to their duties. This status should not be used as cause for discrimination.

### **EXPOSURE TO HEPATITIS C VIRUS**

The route of infection is mainly parenteral. Sexual transmission does occur but is far less frequent.<sup>11</sup> No post-exposure therapy is available for hepatitis C, but seroconversion (if any) must be documented. As for hepatitis B viral infection, the source person must be tested for HCV infection. For any occupational exposure to bloodborne pathogens, counselling and appropriate clinical and serological follow-up must be provided.

### **SHARPS INJURIES**

Needlestick injuries are the commonest of sharps injuries, although other contaminated sharp instruments may also cause injuries. All health care workers with potential exposure should be vaccinated. For other personnel, the risk of hepatitis B, hepatitis C and HIV infection should be assessed and appropriate immunization or chemoprophylactic steps taken

Immediate treatment of such injuries should encourage bleeding and washing thoroughly with running water and an antiseptic solution. Consult the infection control team for further advice.

An incident reporting system should be in place. It should not be seen as punitive; active support by managers should encourage prompt and accurate reporting.

### **TUBERCULOSIS**

Health care workers have varying risks for exposure to tuberculosis (TB). Health care workers at the greatest risk of exposure are those working in TB-risk areas such as medical wards, chest clinics, bronchoscopy units, radiology units, TB laboratories, HIV wards and autopsy rooms. If a staff member has been exposed to TB he or she should report to the Infection Control Practitioner or the Staff Health Nurse depending on the hospital protocol for health care worker exposures.

### **MENINGOCOCCAL MENINGITIS**

Transmission of meningococci to health care staff is most likely within 24 hours of admission of the patient, prior to the patient receiving appropriate antibiotic/chemoprophylaxis. Health care workers in close respiratory contact with such cases should receive chemoprophylaxis with ciprofloxacin or an effective alternative agent. Close respiratory contact with the patient includes mouth-to-mouth contact, sharing of drink containers or cigarettes.

### **SARS**

The health care facility should have a clear set of guidelines for preventing staff exposure to SARS.

Health care workers in contact with patients with suspected or probable SARS should be monitored daily for signs and symptoms of SARS, particularly for changes in temperature. If staff members indicate any signs or symptoms of SARS, they should be assessed by the infection control practitioner or the infection control team as to the appropriateness of home isolation. (See chapter 6.1 for infection control procedures for SARS infections.)

### **OTHER INFECTIONS: VARICELLA, INFLUENZA, PERTUSSIS, DIPHTHERIA, RABIES**

Transmission of these micro-organisms may be uncommon, but policies to manage staff exposure should be developed. Vaccination of hospital staff against varicella is recommended. Influenza vaccinations should be given yearly. Rabies vaccinations may be appropriate in some facilities in countries where rabies is enzootic.

## 6. INFECTION CONTROL PRECAUTIONS FOR SELECTED SITUATIONS

### SEVERE ACUTE RESPIRATORY SYNDROME (SARS)

#### Causative agent

Severe acute respiratory syndrome (SARS) is a recently recognized febrile respiratory illness that was first seen in southern China in November 2002. The organism responsible for the disease is a novel coronavirus – SARS CoV.<sup>12</sup>

#### Mode of transmission

- The novel coronavirus has been found in sputum, tears, blood, urine and faeces.<sup>12</sup>
- The organism is mainly transmitted through droplets discharged through the respiratory tract of the infected person, especially during coughing, sneezing and talking. The chances of infection are therefore highest during close, person-to-person or face-to-face contact with someone who has symptoms of SARS.
- The organism can be shed in the faeces for 30 days and has been shown to survive on hard surfaces for more than 24 hours.<sup>12</sup>
- Therefore contact transmission is an important component, either person-to-person or via contaminated environmental surfaces or equipment.
- Airborne transmission has not been ruled out.

The incubation period is 2-10 days with a median of 4.5 days. The risk of transmission during the prodrome phase of the illness appears to be low.

Prior to having any symptoms patients are not thought to be infectious.

#### Susceptibility

Cases of SARS have been reported mainly among persons who had direct, close contact with an infected person, such as household members or health care workers who cared for a symptomatic patient(s). Exposure may occur before it is recognized that the person has SARS and additional precautions have not been implemented.

#### Clinical picture in SARS patients

The clinical picture of SARS closely resembles that of influenza during the prodromal phase.

The common clinical features are:

- During days 1-3, the patient has a high fever ( $\geq 38^{\circ}\text{C}$ ), headache, muscle ache and respiratory symptoms such as dry cough.
- In addition, some clusters of SARS patients have shown prominent gastrointestinal symptoms (mainly diarrhoea).

- From about days 4-5, the illness progresses into a lower respiratory phase characterized by shortness of breath and worsening of cough.
- Chest X-ray changes are suggestive of atypical pneumonia: early, small hilar or focal interstitial infiltrates, progressing to more generalized patchy interstitial infiltrates.
- Low white cell count and platelet count; abnormal liver function are common; renal function is usually normal.
- From about day 7, almost 90% of cases will begin to improve over the next 1-2 weeks. About 10% of cases will have a severe respiratory illness requiring more intensive support such as oxygen therapy, intubations or mechanical ventilation. Currently there is a high case fatality rate in this group. Case fatality rates are higher in the elderly and those with concurrent illnesses.

### **Clinical case definition of SARS<sup>13</sup>**

The following clinical case definition of SARS has been developed for public health purposes.

A person with a history of:

Fever ( $\geq 38^{\circ}\text{C}$ )

**AND** one or more symptoms of lower respiratory tract illness (cough, difficulty breathing, shortness of breath)

**AND** radiographic evidence of lung infiltrates consistent with pneumonia or respiratory distress syndrome (RDS) **OR** autopsy findings consistent with the pathology of pneumonia or RDS without an identifiable cause

**AND** no alternative diagnosis can fully explain the illness.

### **Laboratory case definition of SARS<sup>13</sup>**

A person with symptoms and signs that are clinically suggestive of SARS **AND** with positive laboratory findings for SARS-CoV based on one or more of the following diagnostic criteria:

#### ***PCR positive for SARS-CoV***

PCR positive using a validated method from:

- At least two different clinical specimens (eg nasopharyngeal and stool) **OR**
- The same clinical specimen collected on two or more occasions during the course of the illness (eg sequential nasopharyngeal aspirates) **OR**
- Two different assays or repeat PCR using a new RNA extract from the original clinical sample on each occasion of testing.

#### ***Seroconversion by ELISA or IFA***

- Negative antibody test on acute serum followed by positive antibody test on convalescent phase serum tested in parallel **OR**

- Fourfold or greater rise in antibody titre between acute and convalescent phase sera tested in parallel.

### ***Virus isolation***

- Isolation in cell culture of SARS-CoV from any specimen **AND** PCR confirmation using a validated method.

Testing should be undertaken only in a national or regional reference laboratory as per WHO recommendations:

Use of laboratory methods for SARS diagnosis, <http://www.who.int/csr/sars/labmethods/en/>

WHO will assist resource-poor countries to confirm their first cases of SARS through laboratory collaboration. See: <http://www.who.int/csr/sars/postoutbreak/en/print.html>

### **Infection control precautions for SARS**

Infection control for SARS involves a two-level approach:

- **Standard precautions (see Chapter 3)** which apply to ALL patients at ALL times including those who have SARS, and
- Additional precautions (see Chapter 3) which should include;
  - droplet precautions
  - contact precautions
  - airborne precautions

A combination of these precautions will give the appropriate infection control.

Strict adherence to these precautions is required to break the chain of infection transmission.

The essential steps include:

- Placing the patient in a single room – isolation, and avoiding unnecessary contact
- Use of personal protective equipment for all in close proximity to the patient or the patient's environment
- Strict personal hygiene of staff (e.g. not touching face or mask, eyes or hair when in the patient's room, ensuring hands are washed after leaving the patient's room)
- If transport of the patient is required, the patient should wear a respiratory mask.

Annex 3 summarizes these steps so infection control practitioners can ensure all precautions are in place.

### **Transportation of patients with SARS**

Limit the movement and transport of patients from the isolation room/area for essential purposes only. If transportation is required out of the isolation room/area the patient should wear a mask and a gown where possible. All staff involved in the transportation should wear personal protective equipment.

### Personal protective equipment used for SARS

Personal protective equipment reduces the risk of infection if used correctly. It includes:

- gloves (nonsterile),
- mask (N95 preferable),
- long sleeved cuffed gown,
- plastic apron if splashing of blood, body fluids, excretions and secretions is anticipated,
- protective eyewear/goggles/visors/face shields,
- cap (to be used in high risk situations where there may be increased aerosols).

### Who should use personal protective equipment?

Anyone who enters the isolation room/area including:

- all health care workers who provide direct patient care (e.g. doctors, nurses, radiographers, physiotherapists),
- all support staff including medical aides and cleaning staff,
- family members or visitors,
- all laboratory workers handling specimens from a patient with SARS,
- all sterilizing service workers handling equipment that requires decontamination and has come from a patient with SARS.

### Waste disposal

- All waste generated in the isolation room/area should be disposed of in suitable containers or bags. All waste from a SARS room should be treated as clinical (infectious) waste.
- Staff responsible for routinely removing waste from isolation wards/areas should wear full personal protective equipment when removing waste.
- One waste disposal bag is usually adequate, providing waste can be placed in the bag without contaminating the outside of the bag. If that is not possible, two bags are needed (double bagging).
- *Liquid waste such as urine or faeces can be safely flushed into the sewer system if there is an adequate sewage system in place.*
- Where there is no adequate sewage system, urine and faeces should be decontaminated prior to being flushed into the sewage system.
- Waste disposal bags should include appropriate biohazard labelling, and be treated and disposed of as per the policy of the hospital and in accordance with national regulations pertaining to hospital waste.

### Specimen collection and transportation

Following **standard precautions**, all specimens should be regarded as potentially infectious and staff should adhere rigorously to protective measures in order to minimize exposure.

Specimens for transport must be placed in leak-proof specimen bags, which have a separate sealable pocket for the specimen (i.e. a **plastic biohazard specimen bag**.) Personnel who transport

specimens should be trained in safe handling practices and decontamination procedures in the case of a spill.

The accompanying request form should be clearly marked as "suspected or probable SARS" and the laboratory notified by telephone that the specimen is "on its way." Specimens should be hand delivered where possible. Pneumatic tube systems should not be used to transport specimens.

### **Hospital screening, admission procedures and triage**

Hospitals need to be prepared for the management of SARS cases.

When a SARS alert has been issued by WHO, patients should be immediately isolated and infection control precautions instituted. For further information see WHO Alert, verification and public health management of SARS in the post-outbreak period: <http://www.who.int/csr/sars/postoutbreak/en/>

### **Care of SARS patients in isolation**

Suspect and probable SARS cases should be cared for in single rooms to prevent direct or indirect transmission.

*Strict adherence to infection control guidelines is absolutely necessary to prevent transmission of infection between patients and from patients to health care workers and others.*

Care of patients in isolation units becomes a challenge when there are inadequate resources, or when the source patient has poor hygienic habits, deliberately contaminates the environment, or cannot be expected to assist in maintaining infection control precautions to limit transmission of microorganisms (children, patients having altered mental state, or elderly).

In caring SARS patients in isolation, the following guidelines are to be followed:

#### ***Preparation of the isolation room***

- Ensure additional precautions by indicating with appropriate signage on the door (for example, biohazard logo).
- Place a log book at the entrance of the isolation room. All health care workers or visitors entering the isolation area must sign the log book.
- Remove all non-essential furniture. The remaining furniture should be easy to clean and should not conceal or retain dirt or moisture, either within or around it.
- Collect linen as needed.
- Stock the hand basin with suitable supplies for hand washing.
- Place appropriate waste bags in the room on a foot-operated bin.
- Place a puncture-proof container for sharps in the room.
- Keep the patient's personal belongings to a minimum. Keep water pitcher and cup, tissue wipes, and all items necessary for attending to personal hygiene within the patient's reach.
- The patient should be allocated his/her own non-critical items of patient care equipment, e.g. stethoscope, thermometer and sphygmomanometers. Any item of patient care equipment that is required for other patients should be thoroughly cleaned and disinfected prior to use.
- Set up a trolley outside the door to hold personal protective equipment. A checklist may be useful to ensure all equipment is available (see Annex 4).

- Place appropriate container with a lid outside the door for equipment that requires disinfection and sterilization. Once equipment has been appropriately cleaned it can be sent to the sterilizing service department.
- Keep adequate equipment required for cleaning and disinfection inside the patients' room.

For more information on isolation rooms see the CDC Guidelines for Isolation Precautions in Hospitals; <http://www.cdc.gov/ncidod/hip/isolat/isolat.htm>. (See Annex 5 for an example diagram of an appropriate isolation room for SARS.)

- Cleaning the room

Scrupulous daily cleaning of the isolation unit is essential to prevent cross infection.

### ***Entering the room***

- Collect all equipment needed.
- Sign the log book
- Wear personal protective equipment
- Enter the room and shut the door.

### ***Attending the patient***

- Give careful instructions and explanations to patient and visitors so that they cooperate fully with the precautions.
- Teach the visitors and the patient how to observe safe and correct procedures in order to prevent spread of infection. (See Annex 6, Infection control advice to contacts of a suspected or probable SARS case.)
- If the patient is a child, isolate the family care giver in the same unit.

### ***Catering***

- Serve food on disposable crockery to be eaten with disposable cutlery (if available).
- Non-disposable crockery and cutlery should be washed using hot water (70°C) and detergent, rinsed and dried.
- Where possible, eating utensils should be cleaned in a dishwasher using a hot water cycle (reaching at least 70°C).

### ***Excreta***

If there is no bedpan flusher/disinfector available in the isolation area, bedpans and urinals should be bagged in the isolation room, taken and emptied immediately and then washed in a bedpan washer/hot boiling water, dried and returned immediately to the patient's room.

If sewage treatment systems are not available, secretions and excretions should be disinfected prior to their discharge into sanitary sewage.

Reusable bedpans, urinals and sputum mugs should be cleaned with a neutral detergent then disinfected with an appropriate disinfectant, for example 5% sodium hypochlorite solution. Wash and dry to reuse.

### *Dressings*

Discard waste material and dirty dressings in clinical (infectious) waste bag. Keep used lotions/medications in the room and do not use for non-SARS patients.

### *Leaving the room*

- Remove personal protective equipment in the correct order:
  1. Remove gloves (peel from hand and discard into rubbish bin)
  2. Use alcohol-based handrub or wash hands
  3. Remove cap and face shield (place cap in bin and if reusable place face shield in container for decontamination)
  4. Remove mask - **by grasping elastic behind ears- do not touch front of mask**
  5. Remove gown (place in rubbish bin)
  6. Use alcohol-based handrub or wash hands
  7. Leave the room
  8. Once outside room use alcohol handrub again or wash hands
- Wash hands using plain soap, antimicrobial agent or waterless antiseptic agent such as an alcohol-based hand gel.

### **Discharging the patient**

- Inform the infection control team when the patient is due to be discharged. (See Annex 7, Infection control checklist: discharge of a patient with suspect or probable severe acute respiratory syndrome (SARS).)
- The patient and family should be educated as to the appropriate precautions to take at home
- A checklist may be used to ensure patients and their family/contacts have been advised of all the appropriate infection control precautions to take (see Annex 7).
- Carry out appropriate cleaning and disinfection of the room.

### **Care of the deceased<sup>14</sup>**

- Health care workers must follow all infection control precautions when caring for the deceased SARS patient.
- Full personal protective equipment must be worn.
- The body should be fully sealed in an impermeable body bag prior to transfer to the mortuary.
- No leaking of body fluids should occur and the outside bag should be clean.
- Transfer to the mortuary should occur as soon as possible after death.
- If the family of the patient wishes to view the body, it may be allowed to do so as long as family members wear personal protective equipment. This should happen before the body is transferred to the mortuary.
- Cultural sensitivity should be recognized and considered in situations where a patient dies and has SARS .

### **Post mortem**

A post mortem examination of someone who had or probably had SARS is classified as a very high-risk procedure.<sup>15</sup> Therefore a post mortem should be avoided if at all possible.

### ***Minimizing the risk from an infected cadaver***

If, however, a post mortem is required, full infection control precautions for SARS should be observed when undertaking the post mortem.

Prevent the production of aerosols by:<sup>16</sup>

- avoiding the use of power saws,
- conducting procedures under water if there is a chance of aerosolization,
- avoiding splashing when removing any organs,
- using clear plastic bags over the cadaver's head while eviscerating the brain – some facilities are equipped with special tents for this procedure

Use the minimal amount of equipment in the autopsy.

Avoid using scalpels and scissors with pointed ends.

Never pass instruments and equipment by hand – always use a tray.

If possible use disposable instruments and equipment.

Keep the number of staff present to a minimum.

### ***Use of a circulator (assistant)<sup>16</sup>***

The pathologist and the anatomical pathology technician will have contact with the patient and therefore may be classified as "dirty or contaminated". The use of a "clean" person as a circulator will help to minimize contact with potentially infected or contaminated tissues, fluids and surfaces.

The circulator will be able to:

- label specimen containers without contamination on the outside of the container,
- complete any paperwork and record spontaneous notes required by the pathologist,
- record organ weights and other records,
- act as a liaison between the pathologist and any clinicians that may be required so that there is no contact with telephones, computers, records, etc.

### ***Mortuary care/ funeral director's premises<sup>17</sup>***

Staff of the mortuary or funeral home must be informed that the deceased had SARS. They must be educated as to the appropriate precautions to take in the event there is exposure to the body.

Embalming is not recommended in the case of SARS:

- contact with the deceased SARS patient should be avoided where at all possible,
- the patient should be buried or cremated as soon as possible to reduce the risk of exposure to staff.

Hygienic preparation of the deceased (e.g. cleaning, tidying of hair, trimming of nails, shaving) should also be discouraged.

### **INFECTIONS WITH MULTIDRUG-RESISTANT ORGANISMS**

The overuse and misuse of antimicrobials has resulted in the development of antimicrobial resistance in many parts of the world.

In health care settings, the spread of resistant organisms is facilitated when handwashing, infection control precautions, and equipment cleaning are suboptimal.

The strategies for control of antimicrobial resistance thus consist of:

- appropriate use of antimicrobials
- strengthening of basic infection control measures.

#### **Appropriate antimicrobial use**

Each health care facility should have an antimicrobial use programme. This policy must be implemented through the Infection Control Committee or an Antimicrobial Use Committee (see below).

- antibiotic use must be justifiable on the basis of the clinical diagnosis and known or expected infecting microorganisms,
- appropriate specimens for bacteriological examination must be obtained before initiating antibiotic treatment, in order to confirm the treatment is appropriate,
- the selection of an antibiotic must be based not only on the nature of the disease and that of the pathogenic agent(s), but on the sensitivity patterns, patient tolerance, and cost,
- the physician should receive timely, relevant information of the prevalence of resistance in the facility,
- an agent with as narrow a spectrum as possible should be used,
- antibiotic combinations should be avoided, if possible,
- selected antibiotics may be restricted in use,
- the correct dose must be used (low dosages may be ineffective for treating infections, and encourage the development of resistant strains, while excessive doses may have adverse effects, and may not prevent resistance).

#### **Antimicrobial use committee**

This committee recommends antibiotics for the formulary, establishes prescribing policies, reviews and approves practice guidelines, audits antibiotic use, oversees education, and interacts with pharmaceutical representatives.

The committee may be a subcommittee of the Hospital Infection Control Committee (HICC) or an independent committee working in liaison with HICC.

The most important antibiotic-resistant bacteria are: methicillin-resistant (or multiresistant) *Staphylococcus aureus* (MRSA), vancomycin resistant *Enterococcus faecium* and *Enterococcus*

*faecalis* (VRE); multiresistant gram-negative bacteria; and multidrug-resistant tuberculosis (MDR-TB).

Organisms with acquired resistance to multiple antibiotics are common in many hospitals. Other organisms may be important in some health care facilities, but this document will concentrate on MRSA, VRE and MDR-TB.

### **Control of endemic antibiotic resistance**

- Ensure appropriate use of antibiotics (optimal choice, dosage and duration of antimicrobial therapy and chemoprophylaxis based on defined hospital antibiotic policy, monitoring and antibiotic resistance, and up-to-date antimicrobial guidelines).
- Institute protocols (guidelines) for intensive infection control procedures and provide adequate facilities and resources, especially for handwashing, infection control precautions (e.g. isolation), and environmental control measures.
- Improve antimicrobial prescribing practices through educational and administrative methods.
- Limit use of topical antibiotics.

### **Methicillin-resistant *Staphylococcus aureus* (MRSA)**

Epidemic strains of MRSA have tremendous potential for nosocomial transmission. MRSA strains are often resistant to several antibiotics and are often sensitive only to vancomycin and one or two other antibiotics. Once introduced into a hospital they spread rapidly, since transmission is usually through the hands of health care staff.

The following precautions are required for the prevention of spread of epidemic MRSA:

- minimize ward transfers of staff and patients,
- ensure early detection of cases, especially if they are admitted from another hospital (screening of high risk patients will ensure early detection and appropriate precautions can be implemented),
- isolate infected or colonized patients in a single room, isolation unit or cohorting in a larger ward,
- treat patients with MRSA pneumonias with airborne precautions in place,
- reinforce handwashing by staff after contact with infected or colonized patients; consider using an antiseptic handwashing agent or alcohol handrub or handgel,
- wear gloves when attending to the patient or when handling MRSA-contaminated materials,
- wear a gown or apron when attending to the patient or when handling contaminated materials,
- develop protocols or guidelines for management of patients and staff during an outbreak,
- ensure that operating surgeons should not perform surgeries until declared negative for carriage.

### **Vancomycin-resistant enterococcus (VRE)**

Enterococci may be cultured from surgical wound infections, liver and intra-abdominal abscesses, and foot ulcers in diabetic patients.

*E. faecium* and *E. faecalis* are commensal organisms in the gastrointestinal tracts of healthy individuals.

### *Transmission*

The major route of transmission of VRE within the health care facility is the hands of HCWs following contact with patients with VRE or their immediate environment. Usually this is associated with inadequate handwashing.

### *Susceptibility*

VRE readily colonizes the bowel without causing symptoms of infection. VRE does not cause diarrhoea.

Patients who are at an increased risk for VRE colonization or infection are, for example:

- critically ill patients (ICU patients),
- immunocompromised patients (patients on chemotherapy or transplant patients),
- patients who have had intra-abdominal or cardiothoracic procedures,
- patients who have central venous catheters,
- patients who have had a prolonged hospital stay, and
- patients who have had recent broad-spectrum antibiotic therapy, or who have received oral or intravenous vancomycin.

It may be necessary to screen for VRE in the health care facility, especially in high-risk patients as above.

### *Infection control measures for VRE*

Standard precautions with additional contact precautions should be applied.

#### *Contact precautions*

- See chapter 3 and Annex 2.
  - It is essential that all staff, visitors or any other person entering the patient's room strictly follow standard and contact precautions.
  - Daily environmental cleaning is essential.
  - Patients must have their own patient care items.

**Any item that enters the patient's room must be decontaminated after it is removed from the room prior to going to another area in the hospital or being used on another patient.**

### **Multidrug-resistant tuberculosis (MDR-TB)**

Tuberculosis (TB) is caused by infection with *Mycobacterium tuberculosis*. It affects one third of the world's population.<sup>18</sup> Of particular concern is the rise in drug-resistant TB and multidrug-resistant TB (MDR-TB). Multidrug-resistant TB is resistant to any combination of anti-TB drugs that includes Isoniazid and Rifampicin (the two most effective anti-TB drugs).<sup>18</sup>

### *Susceptibility*

MDR-TB arises in areas where TB control is poor, such as developing countries.

### ***Occurrence***

- The incidence of MDR-TB in developing countries is high and in some countries it threatens the success of TB control.
- Several geographical areas have been identified by WHO as having a prevalence of MDR-TB greater than 3% of newly diagnosed cases of TB.<sup>18</sup>

### ***Transmission***

- TB is usually transmitted by exposure to airborne droplet nuclei produced by people with pulmonary or laryngeal disease, during expiratory efforts such as coughing and sneezing.
- Prolonged close contact with such patients increases the risk of transmission

### ***Infection control measures for MDR-TB***

- Rapid detection,
- immediate implementation of infection control precautions for all suspect or proven cases,
- diagnosis and treatment of TB,
- transport of patient – patient should wear a surgical mask,
- appropriate infection control precautions include standard precautions plus additional precautions (airborne precautions).

### ***Standard and airborne precautions.***

See chapter 3.

### ***Health care workers***

- HCWs working in areas where there are patients with TB, such as chest clinics, bronchoscopy units, radiology units, and TB laboratories are at greater risk of occupational exposure to TB.
- Such HCW should have yearly Mantoux tests. If they test positive they should have an X-ray and clinical review.

## **INFECTIONS WITH VIRAL HAEMORRHAGIC FEVERS**

Viral haemorrhagic fevers (VHF) are severe acute viral illnesses that will present with a sudden onset of fever, lethargy, weakness and headache. This may be followed by pharyngitis, diarrhoea and vomiting and a maculopapular rash.<sup>11</sup> Haemorrhagic diathesis often occurs along with liver damage, renal failure, central nervous system involvement and terminal shock with multiorgan failure.<sup>11</sup>

Viral haemorrhagic fevers include; Ebola-Marburg viral diseases, African haemorrhagic fever, Marburg virus disease, Ebola virus, haemorrhagic fever. The case fatality rate of Marburg virus infection (reported primary cases ) is approximately 25%, whereas case fatality of Ebola infections in Africa ranges from 50% - 90%.<sup>11</sup>

### **Mode of transmission<sup>11</sup>**

Human to human transmission by:

direct contact with infected blood,  
secretions,  
organs,  
semen,

risk of transmission increases as the illness becomes worse, the highest level of transmission being in the late stages of the illness when the patient is vomiting.

### **Infection control precautions<sup>11,19</sup>**

Strict infection control precautions **MUST** be followed at all times when caring for all patients with VHF. These include:

Standard precautions (see section 3)

Isolation precautions for VHF – These guidelines give only a brief overview.

1. Isolate the patient.
2. Wear personal protective equipment (at all times when in contact with patient or environment).
3. Clean and disinfect spills, waste, and reusable equipment safely.
4. Clean and disinfect soiled linen and laundry safely.
5. Use safe disposal methods for non-reusable supplies and clinical waste.
6. Provide information about the risk of VHF transmission to health care workers.
7. Reinforce the use of VHF isolation precautions with all health care workers.
8. Provide information to families and the community about prevention of VHFs and care of patients.

**For more information see "Infection Control for Viral Haemorrhagic Fevers in the African Health Care Setting"<sup>19</sup>**

(<http://www.cdc.gov/ncidod/dvrd/spb/mnpages/vhfmanual.htm>).

## REFERENCES

1. John, V. and Brachman, P. S. *Hospital Infection*. (See especially Chapter 13, 'Isolation precautions in hospitals', pp 189-199). 4 ed. Philadelphia, PA, Lippincott-Raven Publishers, 1998.
2. World Health Organization. *Prevention of Hospital Acquired Infections-A Practical Guide*. 2 ed. WHO/CDS/EPH/2002.12. Geneva, WHO, 2002.
3. Communicable Diseases Network Australia. *Infection Control guidelines for the prevention of transmission of infectious diseases in the health care setting 2<sup>nd</sup>* Canberra, Department of Health and Aging, Commonwealth of Australia, 2002.
4. Canada Communicable Disease Report. *Infection Control Guidelines. Routine practices and additional precautions for preventing the transmission of infection in health care*. Canada Health. Supplement Vol 25, S4. 1998.
5. Garner, J, and Hospital Infection Control Practices Advisory Committee. Guideline for Isolation Precautions in Hospitals. *Infection Control & Hospital Epidemiology*. 1996. 17:53-80
6. CDC Guidelines for Environmental Infection Control in Health Care Facilities. *MMWR*, June 6, 2003/52(RR10);1-42
7. Weinstein, J.W. Hierholzer, W.J. and Garner, J.S. Isolation Precautions in Hospitals (pp189-199) in Bennett, J. and Brachman, P.(Eds) *Hospital Infections* (Fourth Edition). 1998: Lippincott-Raven Publishers, Philadelphia.
8. Spalding EH (1968) Chemical disinfection of medical and surgical materials. In: Lawrence CA Block SS (eds). *Disinfection, Sterilization and Preservation*. Lea & Febiger, Philadelphia, 517-531.
9. Rutala, W.A. APIC Guideline for selection and use of disinfectants. *American Journal of Infection Control* 1996: 24(4):313-342
10. Muscarella LF (1998). Are all sterilization process alike? *AORN J* 67: 966-970
11. Chin, J. (Editor) *Control of Communicable Diseases Manual* 17<sup>th</sup> Edition, American Public Health Association:2000
12. Wenzel, R.P. and Edmond, M.B. Listening to SARS: Lessons for infection control. *Annals of Internal Medicine*. 2003. 139 (7): 592
13. World Health Organization. *Alert, Verification and public health management of SARS in the post-outbreak period*. 14 August 2003. <http://www.who.int/csr/sars/postoutbreak/en>
14. Claydon, S.M. The high risk autopsy. Recognition and protection. *American Journal of Forensic Medical Pathology*. 1993. 14: 253-256
15. Newsom S.W.B., Rowlands, C. Matthews, J., et al. Aerosols in the mortuary. *Journal of Clinical Pathology*. 1983. 36: 127-132.
16. Healing, T.D., Hoffman, P.N. and Young, S.E.J. The infection hazards of human cadavers. *Communicable Disease Report*. 1995. 5(5):R61-R68.
17. Young, S.E.J. & Healing, T.D. Infection in the deceased: a survey of management. *Communicable Disease Report*. 1995. 5(5):R69-R76.

- 18 World Health Organization. *Guidelines for Establishing DOTS-Plus Pilot Projects for the Management of Multidrug-resistant tuberculosis (MDR-TB)*. WHO/CDS/TB/2000.279
- 19 World Health Organization and Centres for Disease Control and Prevention. *Infection Control for Viral Haemorrhagic Fevers in the African Health Care Setting*. Atlanta, Centres for Disease Control and Prevention, 1998: 1-198.

**Further reading**

1. CDC: Boyce, John M. & Pittet D. Guidelines for Hand Hygiene in Health Care Settings. *Morbidity and Mortality Weekly Report*. October 25, 2002/51/No. RR-16. pp 1-34.
2. CDC. *Guidelines for infection control in health care personnel*. 1998.
3. CDC. Guidelines for hand hygiene in health-care settings. *Morbidity and Mortality Weekly Report*. 2002; 51:RR-16.
4. CDC. Recommendations for isolation precautions in hospitals. <http://www.CDC.gov/ncidod/hip/isolat/isopart2.htm>.
5. Nelson, K. E., Williams C.M. and Graham N.M.H. *Infectious Disease Epidemiology: Theory & Practice*. Aspen Publishers, Maryland, 2001.
6. Wilson, Jennie, *Infection Control in Clinical Practice*. 2 ed. Bailliere Tindall, UK, 2001, pp. 131-153 and 225-264.
7. World Health Organization, South East Asia Regional Office. *Guidelines on Prevention and Control of Hospital Associated Infections*. SEA-HLM-343. New Delhi, WHO, January 2002.
8. World Health Organization, Western Pacific Regional Office. *Interim Guidelines for National SARS Preparedness*. WHO Western Pacific Region, 2003.
9. World Health Organization. *Hospital Infection control guidance for severe acute respiratory syndrome (SARS)*. March 2003. <http://www.who.int/csr/sars/infectioncontrol/en/>
10. Prüss, A. Giroult, E. and Rushbrook, P. eds. *Safe Management of Wastes from Healthcare Activities*. World Health Organization, Geneva, WHO, 1999 (available at : [http://www.who.int/water\\_sanitation\\_health/medicalwaste/en/](http://www.who.int/water_sanitation_health/medicalwaste/en/) ).
11. Prüss, A. and Townsend, W.K. *Teacher's guide: management of wastes from health-care activities* . WHO, Geneva, 1998 (available at [http://www.who.int/water\\_sanitation\\_health/medicalwaste/en/](http://www.who.int/water_sanitation_health/medicalwaste/en/) )

# GLOSSARY

**Airborne infection:** The infection usually occurs by the respiratory route, with the agent present in aerosols (infectious particles < 5µm in diameter)

**Airborne precautions:** These are additional to standard precautions and are designed to reduce the transmission of diseases spread by the airborne route.

**Anteroom:** As an extra precaution to prevent airborne transmission, some single rooms used for isolation purposes may include an anteroom where staff may put on and remove personal protective equipment.

**Clinical waste:** Also known as "infectious waste" – includes waste directly associated with blood, body fluids secretions and excretions. It also includes laboratory waste that is directly associated with specimen processing, human tissues, including material or solutions containing free-flowing blood, and animal tissue or carcasses used for research. Also includes discarded sharps.

**Cohorting:** For infection control purposes, if single rooms are not available or there is a shortage of single rooms, patients infected or colonised with the same organisms can be cohorted (sharing of room(s)). When cohorting is used during an outbreak, these room(s) should be in a well defined area that has been designated for the purpose and is clearly segregated from other patient care areas in the health care facility used for non-infected/colonized patients.

**Contact transmission:** Micro-organisms that are transmitted by direct contact with hands/equipment or indirect contact between and infected or colonized patient and a susceptible patient.

**Contact precautions:** These are additional to standard precautions and are designed to reduce the risk of transmission of micro-organisms by direct or indirect contact.

**Critical site:** Sterile tissue, cavity or bloodstream. Instruments or equipment that will penetrate this site must be sterile.

**Disinfection:** A process of removing micro-organisms without complete sterilization.

**Droplet infections:** Large droplets carry the infectious agent (>5µm in diameter).

**Droplet precautions:** These are additional to standard precautions and are designed to reduce the transmission of infectious spread by the droplet route.

**Health care worker:** Any person working in a health care facility, for example, medical officer, nurse, physiotherapist, cleaner, psychologist.

**Health care facility:** Organization that employs health care workers and cares for patients/clients.

**Health care associated infection** (also known as nosocomial infection and hospital-associated infection): An infection acquired in hospital by a patient who was admitted for a reason other than that infection. An infection occurring in a patient in a health care facility in whom the infection was not present or incubating at the time of admission. This includes infections acquired in the hospital but appearing after discharge, and also occupational infection among staff of the facility.

**High-level disinfection:** For items classified as critical (entering body cavities or mucous membranes) This will destroy all micro-organisms with the exception of heavy contamination by bacterial spores.

**Infection control committee:** Provides a forum for multidisciplinary input and cooperation and information sharing. Representation may include: management, physicians, other health care workers clinical microbiology, pharmacy, sterilizing service, housekeeping, training services.

**Infection control team:** Those health care workers involved in carrying out the day to day infection control programme including the yearly work plan for review by the Infection Control Committee

**Infection control programme:** Incorporates all aspects of infection control, e.g. education, surveillance, environmental management, waste management, outbreak investigation, standard and additional precautions, cleaning, disinfection and sterilization, employee health, quality management in infection control.

**Low-level disinfection:** Disinfection for non-critical items can kill most bacteria, some viruses and some fungi, but cannot be relied on to kill more resistant bacteria such as *M. tuberculosis* or bacterial spores.

**Multiple resistant organisms:** Bacteria that are resistant to many antibiotics. They are more commonly seen in health care facilities than in the wider community. These resistant patterns make them more difficult to treat and they may readily colonise patients and at times health care workers.

**Negative pressure room** This is a term used for an isolation area which receives many air changes per hour (ACH) ( $\geq 12$  ACH for new construction as of 2001;  $\geq 6$  ACH for construction before 2001), and is under negative pressure. In other words, the direction of the air flow is from the outside adjacent space (e.g. the corridor) into the room. It is preferable that the air in a negative pressure room is exhausted to the outside, but it may be recirculated if the air is filtered through a high-efficiency particulate air (HEPA) filter.<sup>6</sup> (For more information see the CDC Guidelines for Environmental Infection Control in Health Care Facilities. MMWR, June 6, 2003/52(RR10);1-42. Also found at: <http://www.cdc.gov/mmwr/preview/mmwrhtml/rr5210a1.htm>)

**Nosocomial infection:** Also known as health-care-associated infection (see above).

**Personal protective equipment:** Includes gloves, gowns, caps, masks – (surgical and N95), and overshoes. These items are used to protect the health care worker from splashes of blood, body fluids, excretions and excretions or from droplets or aerosolization of organisms from the respiratory tract. It is the responsibility of the health care worker to put on the appropriate personal protective equipment in any situation that is likely to lead to exposure of blood, body fluids, excretions and secretions.

**Reprocessing:** The steps that are taken to make an instrument or equipment that has been used (contaminated) ready for reuse again.

**Standard precautions:** These are applied for all patients at all times regardless of their known or presumed infectious status.

**Sterility assurance level:** The acceptable level of sterility is one in a million. This means that of a million products being sterilized by the same method you may statistically expect one of them to be unsterile.<sup>3</sup>

**Sterilization:** The destruction of all micro-organisms. This is defined as a decrease in microbial load. Sterilization can be either conducted by physical or chemical means.

# ACRONYMS

<b>BSL</b>	Biosafety laboratory
<b>CDC</b>	Centers for Disease Control and Prevention (Atlanta, USA)
<b>CJD</b>	Creutzfeldt-Jacob disease
<b>HAI</b>	Hospital-acquired infection or hospital-associated infection
<b>HBV</b>	Hepatitis B virus
<b>HCF</b>	Health care facility
<b>HCV</b>	Hepatitis C virus
<b>HCW</b>	Health care workers
<b>HEPA</b>	High-efficiency particulate air (filters)
<b>HICC</b>	Hospital Infection Control Committee
<b>HIV</b>	Human immunodeficiency virus
<b>ICP</b>	Infection control practitioner
<b>ICU</b>	Intensive care unit
<b>IV</b>	Intravenous
<b>MDR-TB</b>	Multi-drug resistant tuberculosis
<b>MRSA</b>	Methicillin resistant <i>Staphylococcus aureus</i>
<b>PPE</b>	Personal protective equipment
<b>SARS</b>	Severe acute respiratory syndrome
<b>SEARO</b>	WHO South-East Asia Regional Office
<b>SSD</b>	Sterilizing service department
<b>VHF</b>	Viral haemorrhagic fever
<b>VRE</b>	Vancomycin resistant enterococcus
<b>WHO</b>	World Health Organization
<b>WPRO</b>	WHO Western Pacific Regional Office

# ANNEX 1 - HAND WASHING

Appropriate hand washing can minimize micro-organisms acquired on the hands by contact with body fluids and contaminated surfaces. Hand washing breaks the chain of infection transmission and reduces person-to-person transmission.

**Hand washing is the simplest and most cost-effective way of preventing the transmission of infection and thus reducing the incidence of health-care-associated infections.**

All health care personnel and family caregivers of patients must practise effective hand washing. Patients and primary care givers need to be instructed in proper techniques and situations for hand washing.

Compliance with hand washing is, however, frequently sub optimal. Reasons for this include, lack of appropriate equipment, low staff to patient ratios, allergies to hand washing products, insufficient knowledge among staff about risks and procedures, the time required, and casual attitudes among staff towards bio-safety.

## PURPOSE

Hand washing helps to remove micro-organisms that might gain entry and cause disease.

- Washing with soap and water kills many transient micro-organisms and allows them to be mechanically removed by rinsing.
- Washing with antimicrobial products kills or inhibits the growth of micro-organisms in the deep layers.

## TYPES OF HAND WASHING

### Hand washing

Hand washing is usually limited to hands and wrists; the hands are washed for a minimum of 10 – 15 seconds with soap (plain or antimicrobial) and water.

### Hand antisepsis/decontamination

Hand antisepsis removes or destroys transient micro-organisms and confers a prolonged effect. It may be carried out in one of the following two ways:

Wash hands and forearms with antimicrobial soap and water, for 15-30 seconds (following manufacturer's instructions).

Decontaminate hands with a waterless, alcohol-based hand gel or hand rub for 15-30 seconds. This is appropriate for hands that are not soiled with protein matter or fat.

Immersion of hands in bowls of antiseptics is not recommended.

### **Surgical hand antisepsis**

Surgical hand antisepsis removes or destroys transient micro-organisms and confers a prolonged effect. The hands and forearms are washed thoroughly with an antiseptic soap for a minimum of 2-3 minutes. The hands are dried using a sterile towel.

Surgical hand antisepsis is required before performing invasive procedures.

## **FACILITIES AND MATERIALS REQUIRED FOR HAND WASHING**

### **Running water**

Access to clean water is essential. It is preferable to have running water: large washbasins with hand-free controls, which require little maintenance and have antisplash devices.

When no running water is available, use either a bucket with a tap, which can be turned on and off, a bucket and pitcher, or 60%-90 % alcohol hand rub.

### **Materials used for hand washing/hand antisepsis**

**Soap:** Plain or antimicrobial soap depending on the procedure.

**Plain soap:** Used for routine hand washing, available in bar, powder or liquid form.

**Antimicrobial soap:** Used for hand washing as well as hand antisepsis.

- If bar soaps are used, use small bars and soap racks, which drain.
- Do not allow bar soap to sit in a pool of water
- Clean dispensers of liquid soap thoroughly every day.
- When liquid soap containers are empty they must be discarded, not refilled with soap solution.

**Specific antiseptics:** recommended for hand antisepsis

- 2%-4% chlorhexidine,
- 5%-7.5% povidone iodine,
- 1% triclosan, or
- alcoholic rubs.

**Waterless, alcohol-based hand rubs:** with antiseptic and emollient gel and alcohol swabs, which can be applied to clean hands.

**Dispensers** should be placed outside each patient room

<p><b>Alcohol hand-rubs are good for rapid hand decontamination between patient contacts.</b></p>
---

### Facilities for drying hands

**Disposable towels, reusable sterile single use towels or roller towels, which are suitably maintained, should be available.**

If there is no clean dry towel, it is best to air dry hands

<b>Common towels must not be used.</b>
--

Equipment and products are not equally accessible in all countries, or health care facilities. Flexibility in products and procedures, and sensitivity to local needs will improve compliance. In all cases, the best procedure possible should be instituted.

## STEPS IN HAND WASHING

### Preparing for hand washing

- Remove jewellery (rings, bracelets) and watches before washing hands.
- Ensure that the nails are clipped short (avoid wearing artificial nails).
- Roll the sleeves up to the elbow.

Wet the hands and wrists, keeping hands and wrists lower than the elbows (permits the water to flow to the fingertips, avoiding arm contamination).

Apply soap (plain or antimicrobial) and lather thoroughly.

Use firm, circular motions to wash the hands and arms up to the elbows, covering all areas including palms, back of the hands, fingers, between fingers and lateral side of fifth finger, knuckles, wrists and forearms. Rub for minimum of 10-15 seconds.

Repeat the process if the hands are very soiled.

Clean under the fingernails.

Rinse hands thoroughly, keeping the hands lower than the forearms.

If running water is not available, use a bucket and pitcher.

Do not dip your hands into a bowl to rinse, as this recontaminates them.

Collect used water in a basin and discard in a sink, drain or toilet.

Dry hands thoroughly with autoclaved napkins or disposable sterile paper towel, clean dry towel, or air-dry them.

Discard the towel (if used) in an appropriate container without touching the bin lids with hand.

Use a paper towel, clean towel or your elbow/foot to turn off the faucet to prevent recontamination.

A general procedure for hand washing is given in Figure 1.

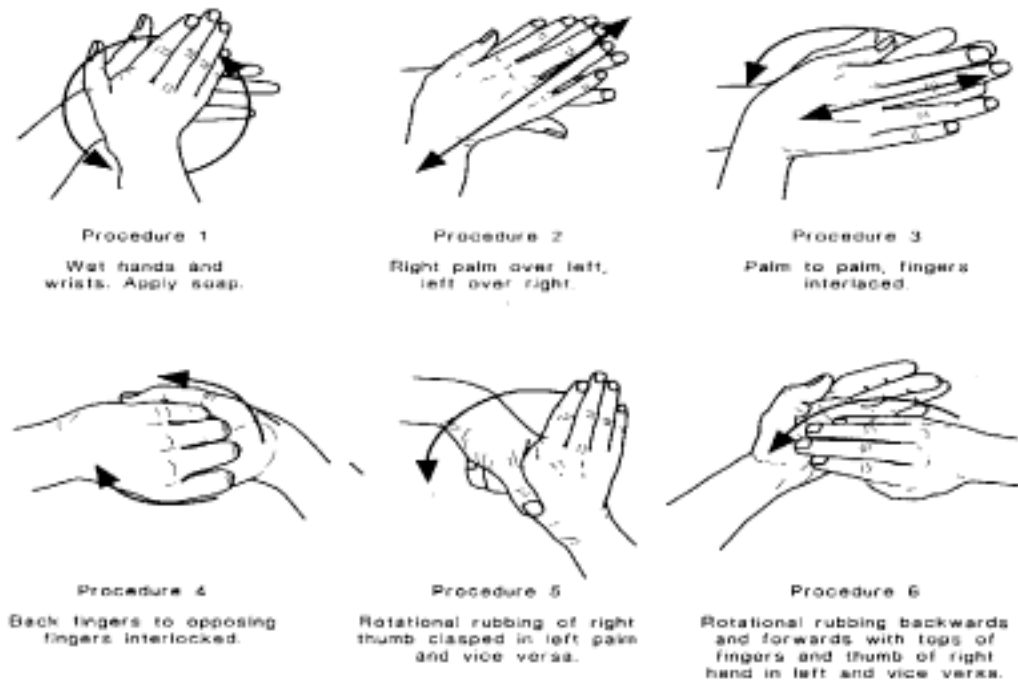

NOTE: Repeat procedures 1-6 until the hands are clean. Rinse hands and pat dry.

### USING ANTISEPTICS, HAND RUBS, GELS OR ALCOHOL SWABS FOR HAND ANTISEPSIS

**Apply the product to the palm of one hand. The volume needed to apply varies by product.**

**Rub hands together, covering all surfaces of hands and fingers, until hands are dry.**

**Do not rinse.**

**Note:** When there is visible soiling of hands, they should first be washed with soap and water before using waterless hand rubs, gels or alcohol swabs.

If soap and water are unavailable, hands should first be cleansed with detergent-containing towellettes, before using the alcohol-based hand rub, gel or swab.

# **ANNEX 2 - PERSONAL PROTECTIVE EQUIPMENT**

## **IF FULL PERSONAL PROTECTIVE EQUIPMENT NEEDS TO BE WORN BEFORE ENTERING THE PATIENT CARE AREA**

There has been much debate about the order for putting on and taking off personal protective equipment. The order for putting on personal protective equipment is not important, however for practicality, the following sequence is given as an example when full personal protective equipment is worn:

Wash hands.

Wear scrub suit or old set of thin clothes before entering the designated changing room or area.

Wear boots /or shoe covers with trousers tucked inside.

Wash hands.

Wear cap.

Wear the mask.

Wear an impermeable apron if necessary.

Wear the gown.

Wear protective eye wear/ goggles.

Wash hands and dry them.

Wear gloves with gown sleeve cuff tucked into glove.

## **REMOVING PERSONAL PROTECTIVE EQUIPMENT WHEN LEAVING THE PATIENT CARE AREA**

The order in which personal protective equipment is removed is not as important as the principle behind choosing such an order. The key principle is that when removing personal protective equipment the wearer should avoid contact with blood, body fluids, secretions, excretions and other contaminants. When hands become contaminated they should be washed or decontaminated with 70% alcohol solution.

An example of how to remove personal protective equipment is given.

Using gloved hands, untie the gown string if tied in front and remove shoe covers.

Remove gloves (fingers under cuff of second glove to avoid contact between skin and outside of gloves) and discard in an appropriate manner.

Wash hands.

Remove gown and apron, without contaminating clothing underneath. Touch only inside of gown and apron while removing. Place in appropriate disposal bag.

Remove goggles, mask, and cap and place in an appropriate container. Dispose according to the health care facility protocol. Remove boots (if worn) and place in appropriate container.

Wash hands up to elbows thoroughly with soap and water, dry or decontaminate in 70% alcohol before leaving facility.

## USE OF FULL PERSONAL PROTECTIVE EQUIPMENT

### Boots/shoe covers

Boots/shoe covers are used to protect the wearer from splashes of blood, body fluids, secretions and excretions.

Waterproof boots should be worn for heavily contaminated, wet flooring and floor cleaning.

### Selecting boots/shoe covers

Shoe covers should be disposable and waterproof

Waterproof boots should be washable

### Wearing boots/shoe covers

Wear waterproof boots if needed

or

wear shoe covers over your personal shoes so as to cover your shoes adequately.

### Removing boots/ shoe covers

Remove shoe covers first with gloved hands and discard.

Remove boots last, before leaving the room and decontaminate

Wash hands thoroughly.

Example of health care worker wearing full personal protective equipment



Shoe covers

## **Caps**

Caps that completely cover the hair are used when splashes of blood and body fluids are expected. They should protect the hair from aerosols that may otherwise lodge on the hair and be transferred to other parts of the health care worker such as face or clothing by the hands or onto inanimate objects.

### ***Selecting cap***

Use a disposable, waterproof cap of an appropriate size which completely covers the hair

### ***Wearing cap***

Wear before masking.

Place or tie cap over the head so as to cover hair adequately.

### ***Removing cap***

Remove cap after removing mask.

Remove by holding inside of the cap and folding inside out.

Discard in proper container

Wash hands immediately.

Example of health care worker wearing cap



Hair cover / cap

## **Masks**

A surgical mask protects health care providers from inhaling respiratory pathogens transmitted by the droplet route. It prevents the spread of infectious diseases such as varicella (chickenpox) and meningococcal diseases (meningococcal meningitis).

An N95 mask protects health care providers from inhaling respiratory pathogens that are transmitted via the airborne route. This helps to prevent the spread of infectious diseases such as TB, MDR-TB and SARS.

In order to prevent the spread of infection, the appropriate mask should be worn by health care providers and visitors when attending to a patient suffering from a communicable disease that is spread via the airborne or droplet route.

A patient with a communicable disease spread via the droplet or airborne route should wear a surgical mask when being transferred to other departments or hospitals.

Disposable masks are for single use only and should be discarded after 4-6 hours use. They should not be stored in bags and re-used, shared or hung around neck, etc. If a mask is splashed wet, it should be changed using clean gloves and strict hand washing.

Type of mask	When to wear	Comments
N95	SARS, open/active pulmonary TB, pneumonic plague	Ideally recommended; but single-use, cost and continuous availability may restrict the use. In such situations, standard surgical masks may be used
P100 and N100	During invasive procedures, collection of respiratory secretions, laboratory work and work in an environment where organisms in concentrated form may be encountered	Ideally recommended; but the fact that filters need to be kept continuously available and can be used only once, may mean that cost considerations restrict their use. In such situations, standard surgical masks may be used.
Standard surgical splash proof masks (not gauze mask)	Mainly when dealing with droplet infections use for airborne infections when N95 masks are not available	Use three/four layers, if used to ensure effective filtration of microorganisms. May be used for one hour only. Discard after one use.

### **Selecting a mask**

A surgical mask should be chosen to be worn in circumstances where there are likely to be splashes of blood, body fluids, secretions and excretions or when the patient has a communicable disease that is spread via the droplet route

An N95 respirator mask needs to be chosen for those circumstances when a patient has a communicable disease that is spread via the airborne route

A mask with a higher level of filtration may be required when dealing with highly transmissible diseases such a viral haemorrhagic fever, when conducting high risk procedures on a patient with SARS.

### **Wearing the mask**

Wash hands and dry.

Remove the clean mask from the container with clean hands.

Ensure the mask is fitted properly. Each N95 mask/respirator is different and must be appropriately fitted to each health care worker– called a "fit test". Health care workers must ensure they know how to properly fit a respirator according to the manufacturers instructions.

If glasses are worn, fit the upper edge of the mask under the glasses. This will help to prevent them from clouding over. A secure fit will prevent both the escape and the inhalation of microorganisms around the edges of the mask and fogging of the eyeglasses.

### **Precautions**

Avoid talking, sneezing, or coughing if possible.

Masks cannot be worn with beards/unshaven faces.

**The mask should completely seal the face at all times to ensure effective filtering of micro-organisms**

For more information about respiratory masks see:  
<http://www.cdc.gov/niosh/npptl/respirators/respsars.html>

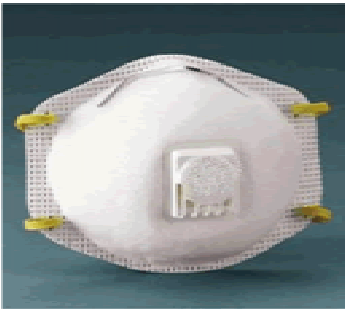

Examples of different types of N95 masks



### ***Removing the mask***

- Wash hands and remove mask keeping outside of the mask in, handle only the strings.
- Discard in an appropriate bag/container and seal the bag.
- Wash hands.

### **Apron**

An apron protects the wearer and the uniform from contact with the contaminated body fluids. Plastic aprons are used over the gown when caring for patients where possible splashes with blood and body substances may occur.

Need not be used if the gown is of impermeable material.

### ***Selecting the apron***

- Select water repellent, plastic aprons, which are disposable
- If disposable ones are not available then reusable plastic aprons can be used.
- Size: long enough to protect the uniform and the gown but should not touch the ground.
- Should cover the front and sides. It should open in the back. A tie around the waist keeps the apron in place.

### ***Wearing the apron***

- Wash hands.
- Ensure that the sleeves are rolled above the elbows before putting on the apron.
- Wear the apron over the uniform and tie around the waist at the back.

### ***Removing the apron***

- Wash hands and dry.
- Remove touching only the inside part of apron.
- Discard folding the outside part in.
- Decontaminate or dispose according to the health care facility guidelines
- Wash hands thoroughly before touching anything else.

Example of gown



**The inside of the apron is considered clean, the outside is considered contaminated. The neck of the apron is considered clean because that part is not touched with contaminated hands.**

## **Gown**

Gowns made of impervious material are worn to protect the wearer's clothing/uniform from possible contamination with micro-organisms and exposure to blood, body fluids secretions and excretions.

The gown should be used only once for one patient and discarded or sent for laundering. Health care workers should remove gowns before leaving the unit.

### ***Selecting a gown***

Gowns should be clean and non-sterile. The gown should be impervious and water repellent. It should be long enough to cover the clothing of the wearer and should have long sleeves and high neck. Disposable gowns are preferable. If they are not available, cotton reusable gowns can be used with a plastic apron underneath.

### ***Wearing the gown***

Wash hands, and dry.

Hold the gown at the neck on the inside permitting to unfold.

Slide hands and arms down the sleeves.

Fasten the ties at the neck.

Overlap the gown at the back as much as possible and secure the waistband. Request assistance to fasten the neck and the waist ties.

### ***Removing the gown***

Remove the gown after removing gloves.

Untie the waist-band with a gloved hand if it is tied in front before removing the gloves.

Remove gloves and wash hands.

Untie the neck-ties (be sure not to touch outside of the gown).

Slide the gown down the arms and over the hands by holding in inside of the sleeves.

Hold the gown with both the hands (inside the shoulders) at the shoulder seams.

Turn the gown inside out (contaminated side in). The hands are then brought together and the gown is rolled and discarded in the container provided.

Discard appropriately.

If reusable - discard if visibly contaminated. If there is shortage of gowns they may be reused during one shift for the same patient. Hang gown with outside facing in when not in use. Discard at the end of each shift.

Wash hands thoroughly before touching anything else.

**Remove a soiled gown as promptly as possible and wash hands immediately to avoid transfer of micro-organisms to other patients or environments**

### *Protective eyewear/goggles*

Protective eyewear/goggles should be worn at all times during patient contact when there is a possibility that a patient's body fluids may splash or spray onto the caregiver's face/eyes (e.g. during throat, endotracheal and tracheostomy suctioning, removal of indwelling catheter etc). The amount of exposure can be reduced through the use of protective eyewear. Full face shields may also be used to protect the eyes and mouth of the health care worker in such high-risk situations.

**Ordinary spectacles do not provide adequate protection, although caregivers may wear their own glasses with extra protection added at the sides. Goggles that fit over glasses are available. Protective eyewear should be changed after each shift.**

**Protective eyewear should be washed and decontaminated after removal and in between use.**

### *Selecting protective eyewear*

Goggles should be made of clear polycarbonate plastic with side and forehead shields. These should be optically clear, antifog and distortion-free.

Goggles that fit over glasses are also available. Disposable goggles are preferred but reusable ones can be used after cleaning and decontamination.

### *Wearing protective eye wear*

Wear the eyewear by securing it over the bridge of the nose and also over the mask.

### *Removing protective eye wear*

Remove and place in appropriate container for cleaning and decontamination prior to reuse by next person.

Goggles /Eye protection



## Gloves

Use gloves when there is potential exposure to blood, body fluid, excretions or secretions.

Change gloves between patients, between tasks and procedures on the same patient, and when they become soiled.

Remove gloves promptly after touching contaminated items and environmental surfaces and before moving to another patient.

Remove gloves before leaving the patient's bedside and decontaminate hands immediately.

After glove removal and hand washing ensure that hands do not touch potentially contaminated environmental surfaces or items in the patient's room.

Discard gloves after attending to each patient.

**The reuse of single-use gloves is not recommended.**

## Selecting gloves

Use disposable gloves that are:

- clean/non-sterile for routine care of the infectious patients;
- sterile for invasive procedures.

Use heavy-duty rubber gloves for cleaning instruments, handling soiled linen or dealing with spills of blood and body fluids. They can be washed and reused.

Choose gloves that fit properly.

Check there is no puncture in gloves. Do not use gloves if they are torn, as punctured gloves do not provide protection.

**Clean, non-sterile, disposable, single use gloves are recommended for routine care of patients with highly transmissible infections.**

## Wearing gloves

Wash hands and dry them.

Pick up the first glove by its cuff.

Wear the first glove. Bunch the glove up and then pull it onto the hand; ease fingers into the glove.

Repeat for the other hand.

***Removing gloves***

**When removing personal protective equipment, remove gloves first.**

Grasp the outside of one glove, near the cuff, with the thumb and forefinger of the other hand. Pull the glove off, turning it inside out while pulling and holding it in the hand that is still gloved.

Hook the bare thumb or finger inside the remaining glove and pull it off by turning it inside out and over the already removed glove to prevent contamination of the ungloved hand.

Roll the two gloves together taking care not to contaminate the hands. See picture below

Discard appropriately

Wash hands or decontaminate with 70% alcohol hand rub/solution.



# **ANNEX 3 - INFECTION CONTROL: A QUICK REFERENCE GUIDE FOR SARS**

## **SUMMARY LIST OF THINGS TO THINK ABOUT FOR INFECTION CONTROL PRACTITIONERS**

Anything that enters the room must be cleaned or placed into a clean bag before it is removed from the environment:

    this includes people, i.e. clean hands and remove the outside layer of clothing before exiting the room,

    and equipment, i.e. place into a container for cleaning or for removal to the sterilizing department.

1. A suspect or probable SARS patient should be placed in a single room – if possible one with negative pressure.
2. Only staff/visitors who have been educated about SARS should enter the room.
3. All staff/visitors who enter the room should sign a log book.
4. All health care workers (and visitors) must wear personal protective equipment when entering the room.
5. The patient must wear a surgical face mask when in contact with staff/visitors.
6. The infection control SARS equipment trolley should remain outside the door (see Annex 4).
7. Patients should have clinical equipment (e.g. sphygmomanometer, thermometer) dedicated to their exclusive use
8. Sterile items should be disposable where possible. Reusable items should be placed in a plastic bag and then into another plastic bag inside the equipment collection bin on the trolley. Request the sterile service department to collect.
9. Alcohol-based handrub should be located in and outside the room.
10. The patient's room must be cleaned each day – including all horizontal surfaces.
11. Cleaning equipment must be cleaned after each use. Mop heads should be sent to the laundry for proper laundering in hot water.
12. Pathology specimens must be taken directly to the laboratory. Request form must indicate “suspected or probable SARS”.
13. Used linen should be placed in a linen bag inside the room and then into another bag outside the room. Take immediately to laundry collection area – treat as per normal soiled/contaminated linen.
14. All waste should be discarded into clinical waste bag inside the room. When waste is to be collected for disposal, place in another bag outside the room and then treat as "normal" clinical/contaminated/infectious waste.
15. A telephone should be set up in the patient's room

## ANNEX 4. SUGGESTED CHECKLIST FOR SARS TROLLEY/TABLE

Items should be kept on this trolley at **all times** so that personal protective equipment is always available for staff.

Equipment	Stock present
Face shield/eye protection goggles	
Single use gloves for clinical use (sizes: small, medium, large)	
Gloves (reusable for environmental cleaning)	
Theatre caps (optional for high-risk situations but should be available)	
P2 (N95) masks	
Surgical masks	
Single-use long sleeved gowns	
Single-use plastic aprons	
Alcohol-based handrub <b>or</b> alternative method for washing hands in clean water	
Soap	
Disinfectant	
Clean towel	
Appropriate disinfectant for environmental cleaning	
<b>Pathology equipment</b> Biohazard Pathology Specimen bags FBC tube EDTA tube NPA tubing set <b>or</b> Sterile dacron or rayon swab sticks with plastic shafts and Tube containing Viral Transport Media with a lid Request form Stool specimen jar Urine specimen jar	
Large plastic bags	
Appropriate waste bags	
Linen bags	
Collection container for used equipment	

## ANNEX 5. ISOLATION ROOM

Example drawing of a typical SARS isolation facility.

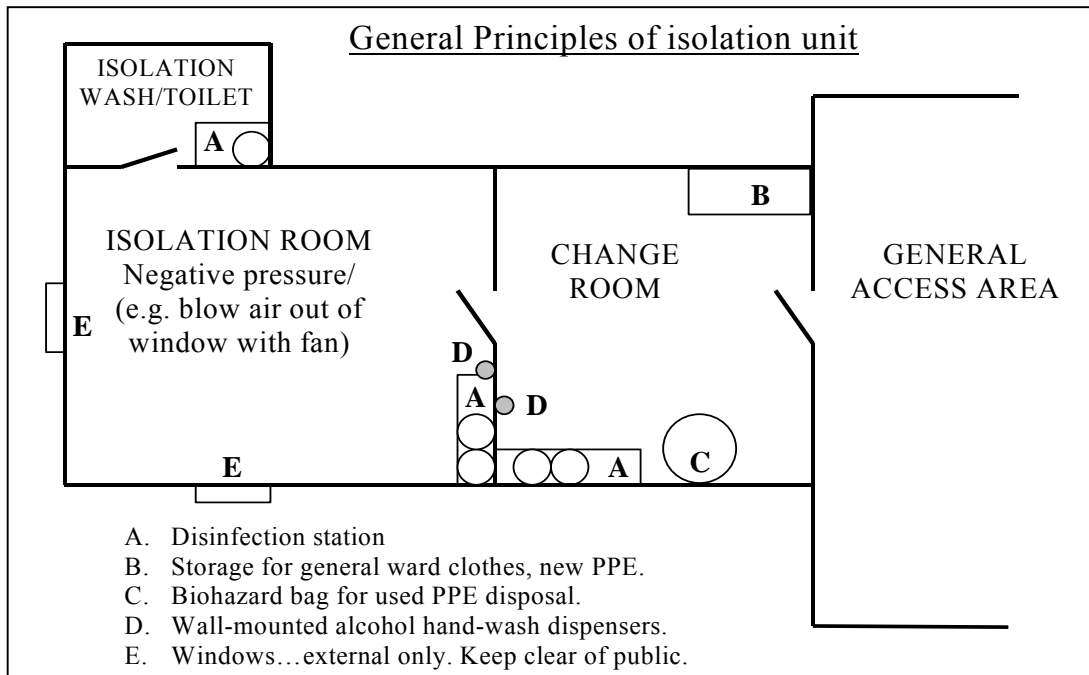

## **ANNEX 6 - INFECTION CONTROL ADVICE TO CONTACTS OF SUSPECT OR PROBABLE SARS CASES**

For contacts of suspect or probable SARS patients, careful hand hygiene is urged, including hand washing with soap and water. If hands are not visibly soiled, alcohol-based hand rubs may be used as an alternative to hand washing. For the safety of others, you should:

Ensure that all household members carefully follow good hand hygiene (e.g. frequent hand washing or use of alcohol-based hand rubs), particularly after contact with body fluids (e.g. respiratory secretions, urine, or faeces).

Pursue normal activities but isolate yourself quickly if you develop a fever or feel unwell, and seek medical attention.

### **KNOWN EXPOSURE TO A CASE**

*If you have been exposed to a case you need to monitor your health for 10 days after exposure. You should take your temperature daily (see below) and report by phone to the infection control practitioner in your health facility.*

#### **Infection control guidelines for household contacts living with a case**

Persons with suspect or probable SARS may have a moderate illness that can be managed with home isolation. In this instance household members need to ensure infection control procedures are strictly adhered to.

People with probable SARS need to ensure they do not pass the infection to others in the home. If they have ongoing respiratory symptoms they should sleep in separate rooms, wear surgical mask when in a room with others, have their own eating utensils and not share any linen or towels with others. Eating utensils, towels, and bedding can be used by others after routine cleaning. Used tissues should be discarded into the toilet or a plastic bag into the rubbish.

SARS patients with respiratory symptoms, should wear surgical masks, if tolerated. If the patient is unable to tolerate a mask, household members should wear N95 masks when in close contact with the person.

All household members should carefully follow good hand hygiene (e.g. frequent hand washing or use of alcohol-based hand rubs), particularly after contact with body fluids (e.g. respiratory secretions, urine, or faeces), and cover their mouths and noses with a facial tissue when coughing or sneezing.

Environmental surfaces should be cleaned with warm water and detergent, followed by wiping with a household disinfectant, eg. diluted bleach (following the manufacturer's instructions).

Household members or other close contacts of SARS patients who develop fever or respiratory symptoms should see a doctor. When possible, in advance of the evaluation,

health care providers should be informed that the individual is a close contact of a possible SARS patient.

If they do not experience fever or respiratory symptoms, household members or other close contacts of SARS patients need not limit their activities outside the home. The exception to this is where the contact with the SARS case was in a SARS-affected area.

**How to record your body temperature: follow these instructions carefully**

To ensure accurate measurement of your temperature, do not take your temperature for

- 30 mins after having a cold drink
- 30 mins after having a hot drink
- 30 mins after having a hot shower or bath
- 30 mins after exercising
- 30 mins after smoking, and
- do not take Aspirin, Panadol or Panadeine for 4 hours prior to taking temperature

**Using a digital thermometer: see opposite**

- Press on/off button
- Wait until thermometer resets and beeps
- Place tip under the tongue, wait until the thermometer beeps
- Record the temperature and the time it was taken



**Using a mercury thermometer: see below**

- Hold the thermometer firmly by the top and shake downwards firmly
- Shake the thermometer till the mercury level falls back to the bulb reservoir
- Place the thermometer bulb under the tongue and leave in place for 4 minutes (monitor with the second hand on a clock)
- Record the temperature and the time it was taken

**Remember – contact the appropriate SARS contact person/s if your temperature is 37.5°C or above**

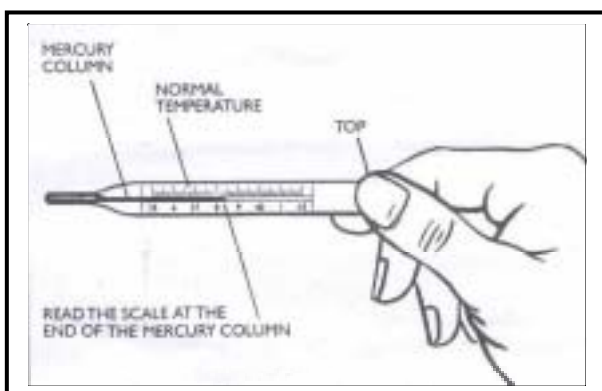

# ANNEX 7 - INFECTION CONTROL CHECKLIST

## DISCHARGE OF A PATIENT WITH SUSPECT OR PROBABLE SEVERE ACUTE RESPIRATORY SYNDROME (SARS)

Before the patient is discharged, ensure that the following have been attended to:

The patient	Tick
1. The patient has been informed of any follow-up blood tests required (when, where and given contact numbers)	
2. The patient has been given the patient information sheet for SARS and has been educated accordingly	
3. The patient is aware that a member of the SARS team will be making regular contact with him or her	
4. The patient has been educated as to what the infection control precautions are in the home situation. For example:  (a) Whenever he or she has contact with another person he or she must wear a surgical mask <b>or</b> the contact must wear an N95 mask  (b) The patient should remain at home for the duration required	
5. The patient has been educated on how to take his or her temperature twice daily	
6. The patient has been given a supply of surgical masks and has been advised where to obtain further masks from	

**The patient's family/contacts**

1. The patient's family/contacts have been given the information sheet for contacts of a patient with SARS and educated accordingly	
2. The patient's family/contacts have been advised of the infection control precautions for living with/having contact with a patient with SARS (e.g. to wear the N95 mask when in contact with the patient if the patient is not able to wear a surgical mask, the patient should remain at home for the duration required)	
3. The patient's family/contacts have been educated on how to wear the N95 mask.	
4. The patient's family/contacts have been given a supply of N95 masks and advised where more masks can be obtained	
5. The patient's family/contacts have been advised that a member of the SARS team will be in contact with them.	

## ACKNOWLEDGEMENTS

Many members of the SARS teams at the South-East Asia and Western Pacific Regional Offices contributed to these guidelines.

The first few drafts of the document were developed and/or reviewed by:

Dr Manju Vatsa  
Dr Rob Condon  
Ms Michelle Cullen  
Ms Penny Clayton  
Ms Glenys Harrington  
Ms Peta-Anne Zimmerman

The document was further developed following a meeting in Manesar, Haryana, in August 2003. The participants at that meeting were:

Ms Karen Shaw  
Dr Duangvadee Sungkhobol  
Dr Rohini Kelkar  
Dr Nita Munshi  
Dr Manju Vatsa  
Associate Professor Wilawan Senaratana  
Dr Sudershan Kumari  
Dr Rajesh Bhatia  
Dr Mel Velmonte

WHO gratefully acknowledges the contribution of the many people who played a part in developing these guidelines, as well as the many infection control experts in countries of the South-East Asia and Western Pacific Regions who reviewed them and made valuable suggestions. In particular, thanks are due to Dr Luis Diaz for his advice on environmental management and to Dr Philippe Calain for his advice regarding cleaning the environment and reprocessing of instruments and equipment for highly transmissible diseases in resource-poor areas. Dr Calain's extensive experience working with viral haemorrhagic fever (Ebola) patients in Africa proved very helpful in the development of these guidelines.